



RECORD THIS INFORMATION FOR FUTURE REFERENCE
BEFORE INSTALLING THE UNIT:

Model No. _____ Serial No. _____
Product No. _____
Date Purchased _____ Place of Purchase _____

USA
SERVICE OFFICE
The Dometic Corp.
509 So. Poplar St.
LaGrange, IN 46761
219-463-4858

CANADA
Dometic Dist.
866 Langs Dr.
Cambridge, Ontario
CANADA N3H 2N7
519-653-4390

**For Service Center
Assistance Call:**
800-544-4881

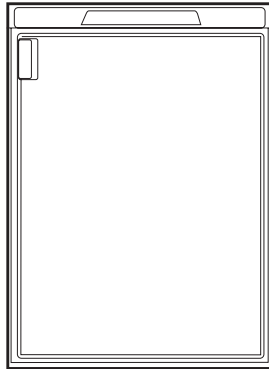

ABSORPTION REFRIGERATORS FOR LP-GAS AND ELECTRIC OPERATION

MODELS

RM2452 RM2552 RM2453 RM2553



FOR YOUR SAFETY

If you smell gas:

1. Shut off gas supply at main valve.
2. Open windows.
3. Don't touch electrical switches.
4. Extinguish any open flame.
5. Immediately call your gas supplier.

! WARNING

Improper installation, adjustment, alteration, service or maintenance can cause injury or property damage. Refer to this manual. For assistance or additional information consult a qualified installer, service agency or the gas supplier.

! AVIS

Cet appareil doit être réparé seulement par un réparateur autorisé. Modification de l'appareil pourrait être extrêmement dangereuse, et pourrait causer mal ou mort.

FOR YOUR SAFETY

Do not store or use gasoline or other flammable vapors and liquids in the vicinity of this or any other appliance.

INSTALLATION & OPERATING INSTRUCTIONS

REFRIGERATOR MODELS

RM2452, RM2453 RM2552, RM2553

INDEX	Page
Installation	2
Operating Instructions	9
Maint. & Service	12

1. GENERAL INSTRUCTIONS

This appliance is designed for storage of foods and storage of frozen foods and making ice.

The refrigerators outlined herein have been design certified by A.G.A. under ANSI Z21 .19 Refrigerator Standard for installation in a mobile home or recreational vehicle and are approved by the Canadian Gas Association.

The certifications are, however, contingent on the installation being made in accordance with the following instructions as applicable.

In the U.S.A., the installation must conform with:

1. National Fuel Gas Code ANSI Z223.1 -(latest edition)
2. Manufactured Home Construction and Safety Standard, Title 24 CFR, Part 3280
3. Recreational Vehicles ANSI A1 19.2-(latest edition).

The unit must be electrically grounded in accordance with the National Electric Code ANSI/NFPA 70-(latest edition) when installed if an external alternating current electrical source is utilized.

4. Any applicable local code.

In Canada, the installation must conform with:

1. Current CGA B 149 Gas Installation Codes
2. Current CSA Standard Z 240.4 GAS-EQUIPPED RECREATIONAL VEHICLES AND MOBILE HOUSING
3. Any applicable local code

The unit must be electrically grounded in accordance with the CANADIAN ELECTRICAL CODE C 22 Parts 1 and 2.

2. VENTILATION

The installation shall be made in such a manner as to separate the combustion system from the living space of the mobile home or recreational vehicle. Louver openings for air supply or for venting of combustion products shall have a minimum dimension of not less than 1/4 inch.

Proper installation requires one fresh air intake and one upper exhaust vent. The ventilation kits shown in this instruction manual have been certified for use with the refrigerator model listed in the Table. For "Certified Vent System Kits" see Section B. The ventilation kits must be installed and used without modification. An opening toward the outside at floor level in the refrigerator compartment must be provided for ventilation of heavier-than-air fuel gases. The lower vent of the recommended kits is provided with proper size openings. The flow of combustion and ventilation air must not be obstructed.

The lower side vent is fitted with a panel which provides an adequate access opening for ready serviceability of the burner and control manifold of the refrigerator. This should be centered on the back of the refrigerator.

3. CERTIFIED INSTALLATION

Certified installations require one roof vent and one lower side vent.

For certified vent system kits, see Section B.

For further information, contact your dealer or distributor.

4. METHOD OF INSTALLATION

The method of installation is shown in FIG. 1. It is essential that all maximum or minimum dimensions are strictly maintained as the performance of the refrigerator is dependent on adequate flow of air over the rear of the refrigerator.

FIG. 1

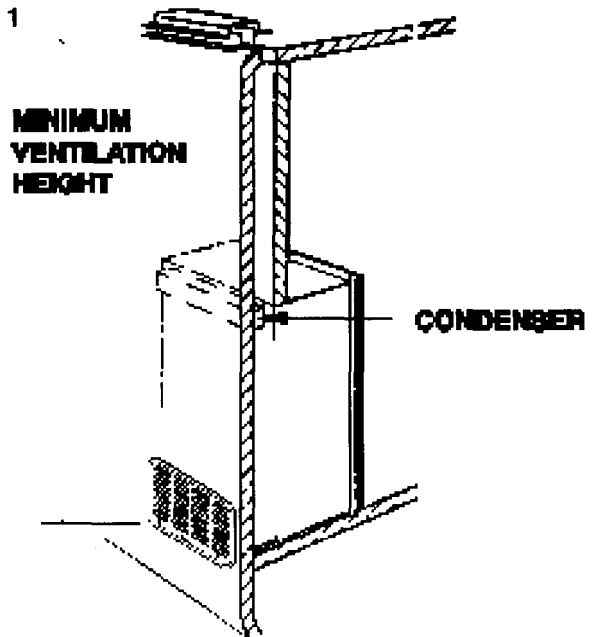

5. VENTILATION HEIGHTS

Refer to FIG 1., Page 2

Installation with roof vent and lower side vent	Minimum Ventilation heights in:	
REFRIGERATOR	INCHES	MM
RM2452, RM2453	37-3/4	960
RM2552, RM2553	44-1/2	1130

LOWER VENT CUTOUT



UPPER VENT CUTOUT

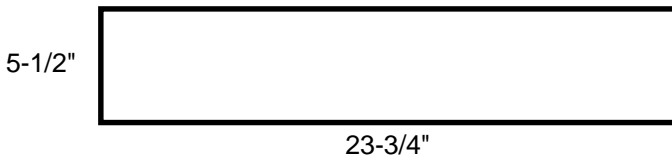

NOTE: All cutout dimensions are +/- 1/8".

6. CLEARANCES

Minimum clearances in inches to combustible materials are:

G: Top	0"
K: Side	0"
L: Bottom	0"
M: Rear	0"
N:	See NOTE

NOTE: Clearance "M" is between the rearmost part of the refrigerator and the wall behind the refrigerator.

NOTE: Clearance "N" is the distance between the bottom of the lower vent to the roof material. For ventilation height, refer to *Section A. Installation, Item 5. Ventilation Heights*. See FIGS. 1 & 2.

FIG. 2

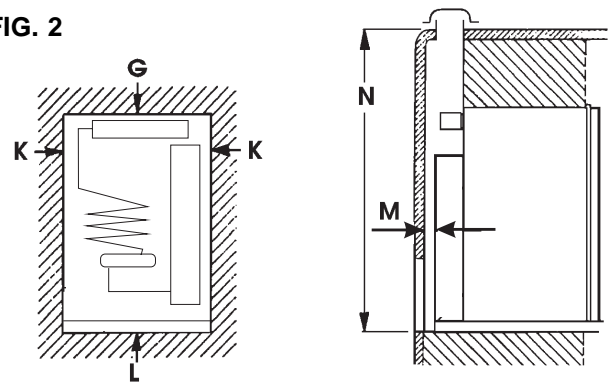
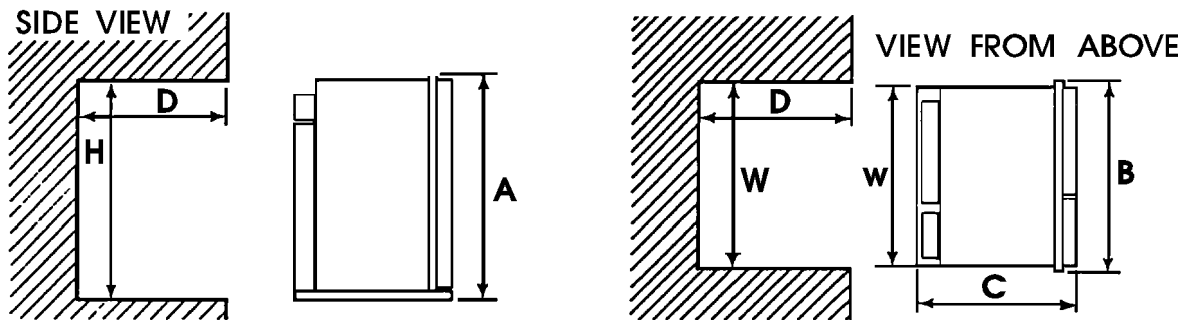

FIG. 3



Refrigerator Model	Overall Dimensions			Recess Dimensions			Total Ref. Vol.
	Height A	Width B	Depth C	Height H	Width W	Depth D	Cu. Ft.
RM2452,2453 (In.)	36-7/8	24-7/8	24-7/8	36-9/16	23-11/16	24	3.7
	(mm)	937	632	632	928	601	
RM2552,2553 (In.)	43.0	24-7/8	24-7/8	42-5/8	23-11/16	24	4.7
	(mm)	1093	632	632	1082	601	

7. INSTALLING REFRIGERATOR IN ENCLOSURE

NOTE: DO NOT install the appliance directly on carpeting. Carpeting must be removed or protected by a metal or wood panel beneath the appliance, which extends at least the full width and depth of the appliance.

Any space between the counter, storage area or ceiling can trap heat produced at the rear of the refrigerator. Any space between the top and sides of the refrigerator should be blocked for maximum refrigerator performance.

CONDENSATE WATER DRAIN HOSE: A 3/4" hole must be drilled through the flooring in the opening of the base plate on the rear of refrigerator (see FIG. 5D). The installer must make sure that the hose does not kink when run through the floor. Seal around the hose where it goes through the hole. If a longer hose is required, follow the illustration shown below:

OPTION A:

- 1) Remove black water check valve from hose.
- 2) Add additional hose
- 3) Reinstall black water check valve

OPTION B:

- 1) Cut drain hose at location shown below.
- 2) Install new drain hose between pieces cut.

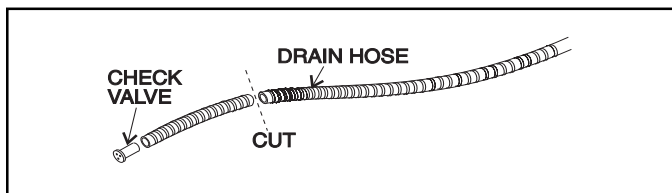

NOTE: Black water check valve must be reinstalled to ensure proper refrigerator operation. **DO NOT KINK HOSE.**

OPTION C:

In vehicles where routing the drain hose through the floor is not possible, a metal clip is available. The clip is used to drain water out through the side vent.

Part No. 3106590.007 Clip for plastic side vent (Qty. 50)

Part No. 3106590.015 Clip for plastic side vent (Single)

Part No. 3106559.002 Clip for metal side vent (Qty. 50)

Part No. 3106559.010 Clip for metal side vent (Single)

INSTALLATION: The refrigerator must be installed in a substantial enclosure and must be level. When installing the refrigerator in the enclosure, all areas within the recess in which the refrigerator is installed must be sealed. Make sure that there is a complete seal between the front frame of the refrigerator and the top, sides and bottom of the enclosure. A length of sealing strip is applied to the rear surface of the front frame for this purpose. Also apply a sealing strip to the foremost floor of the enclosure and apply a second sealing strip to the bottom of the trim strip on the front base as shown in FIG. 4. The sealing should provide complete isolation of the appliance's combustion system from the vehicle interior.

A wood strip must be in place across the upper opening of the enclosure. The top frame of the refrigerator will be anchored to the wood strip with screws. See FIG. 2. The dimensions shown in FIG. 3 will give you adequate space for proper installation.

NOTE: If the door is hinged and it needs to be changed to the opposite side, it must be done before the refrigerator is installed in the enclosure. See Step. 13.

FIG. 4

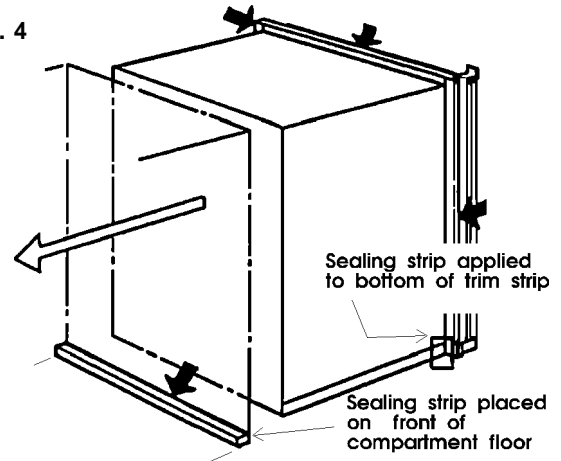

NOTE: Be careful not to damage the sealing strip applied to the floor of the enclosure when the refrigerator is put in place.

The refrigerator is secured in the enclosure with six screws. They must be installed in the following order:

a. First: Two screws are installed in front decoration strip and through the front base.

- 1) The front strip is to be installed after the refrigerator is set into the alcove. The strip is shipped as a loose part.
- 2) Install the lower front strip by sliding it under the bottom hinge plate as shown in FIG. 5. The hinge plate can be on the right or left side depending on the door swing.

FIG. 5

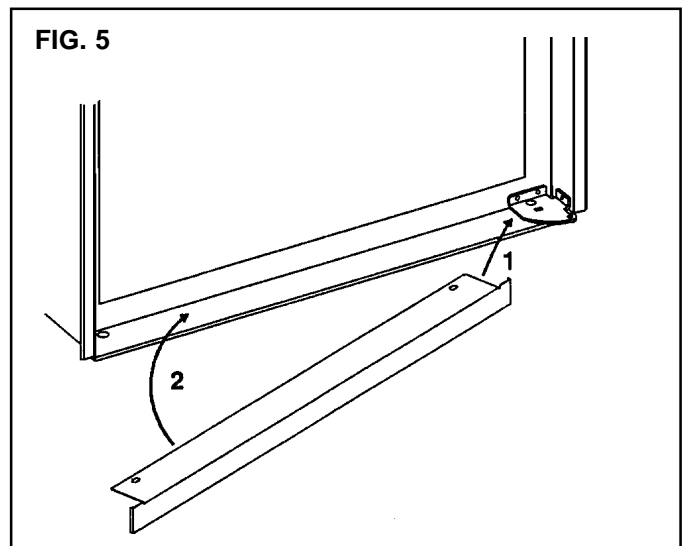

- 3) When the front strip is in place, install one screw through the hinge and into the floor. The second screw is installed with a washer on the opposite side. (See FIG. 5A)

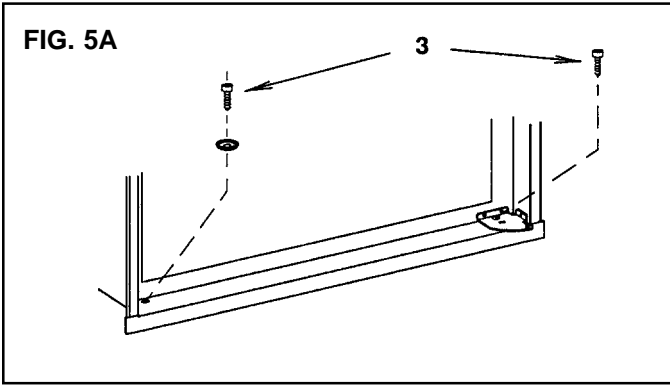

b. Second: Install the two screws in the top frame.

- 1) The top decoration panel must be removed from the refrigerator before the screws can be installed. Open refrigerator door and gently push the tabs out of the hole in the hinge with flat blade screwdriver. See FIG. 5B.
- 2) Carefully tilt the top decoration panel and lift up to remove from top frame. See FIG. 5B.

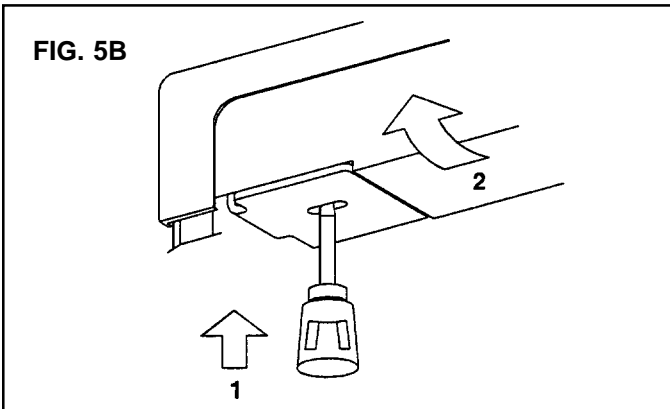

- 3) Install the second two screws in the top frame as shown in FIG. 5C.

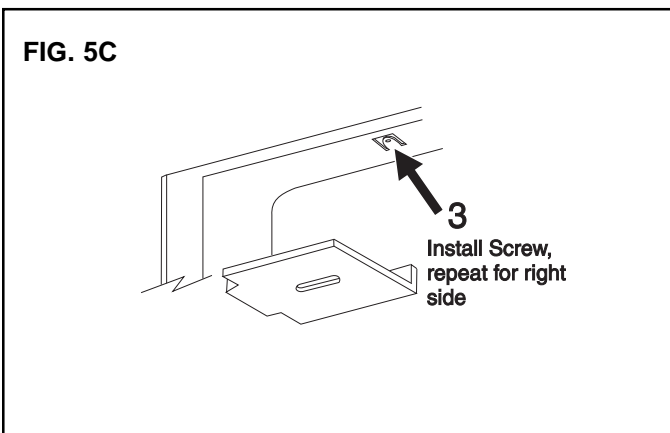

- 4) Replace the top decoration panel. Be careful not to pinch the wires. Make sure the tabs snap back into the holes in the hinge plate.

C. Third: Two screws installed as shown in rear base. See FIG. 5D.

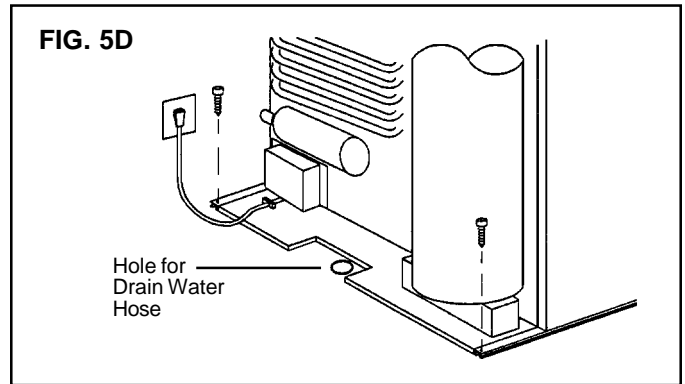

Failure to follow the sequence in securing the refrigerator in the enclosure can cause leakage between the frame and cabinet.

8. GAS CONNECTION

Hook up to the gas supply line is accomplished at the manual gas shutoff valve, which is furnished with a 3/8" SAE (UNF 5/8" – 18) male flare connection. A backup wrench **must** be used when tightening gas supply fitting. All completed connections should be checked for leaks with a noncorrosive leak detector. (See FIG. 6 – Gas tubing may have a different orientation than shown).



The gas supply system must incorporate a pressure regulator to maintain a supply pressure of not more than 13-1/2 inches water column (static) no load.

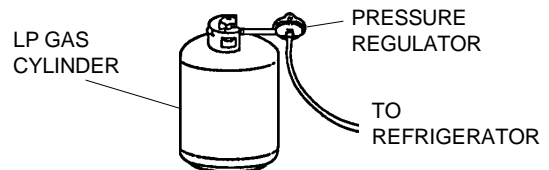

When testing the gas supply system at test pressures in excess of 1/2 psig, the refrigerator and its individual shutoff valve must be disconnected from the gas supply piping system.

FIG. 6

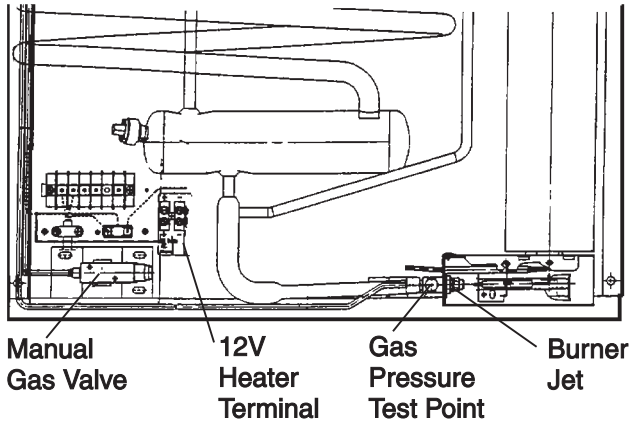
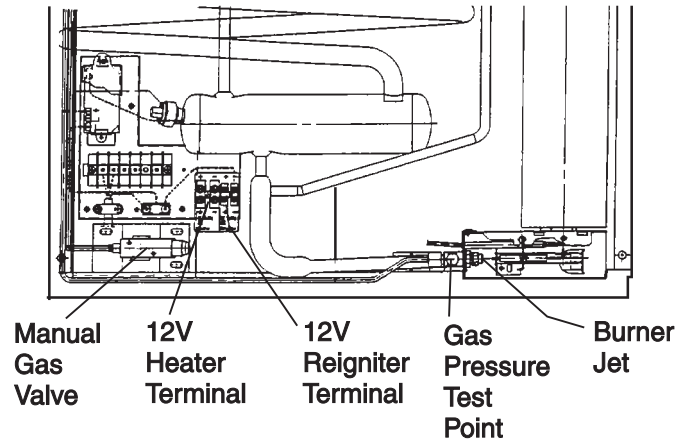

FIG. 6A



When testing the gas supply system at pressures less than or equal to 1/2 psig, the appliance must be isolated from the gas supply piping by closing its individual manual shutoff valve.

In case detailed instructions on the installation and connection to the gas supply are required, contact your dealer or distributor.

9. TESTING LP GAS SAFETY SHUTOFF

The gas safety shutoff must be tested after the refrigerator is connected to LP gas supply.

To test the gas safety shutoff, proceed as follows:

REFRIGERATORS WITH PIEZO IGNITOR (RM2452 & RM2453)

- A. Start the refrigerator according to the instructions, and switch to gas mode. See "Section C. Operation Instructions, Item 3. Gas Operation."
- B. Check that the gas flame is lit. This can be observed on flamed indicator (E). (See FIG. 7)
- C. Close the gas valve by turning the knob "A" back to "OFF" position. (See FIG. 7).

- D. Wait for one minute.
- E. Remove burner cover plate. (See FIG. 6A). Open the gas valve by turning knob "A" to position "GAS" without pushing the buttons "C" and "D". (See FIG. 7). Apply commercial leak check bubble solution to the burner jet
- F. No bubbles should appear at the opening of the burner jet. The presence of bubbles indicates a defective gas safety shutoff, and service is required.
- G. If no bubbles were present at the burner jet, the gas safety valve is working properly. Rinse jet thoroughly with fresh water before proceeding. Be careful not to damage burner jet. Replace cover and turn the main switch OFF and back ON. (See "Section C. Operation Instructions, Item 2. Control Panel"). Normal operation of the burner should return. Allow the burner to operate for a minimum of 5 minutes.

! WARNING

DO NOT use a flame to check for leaks.

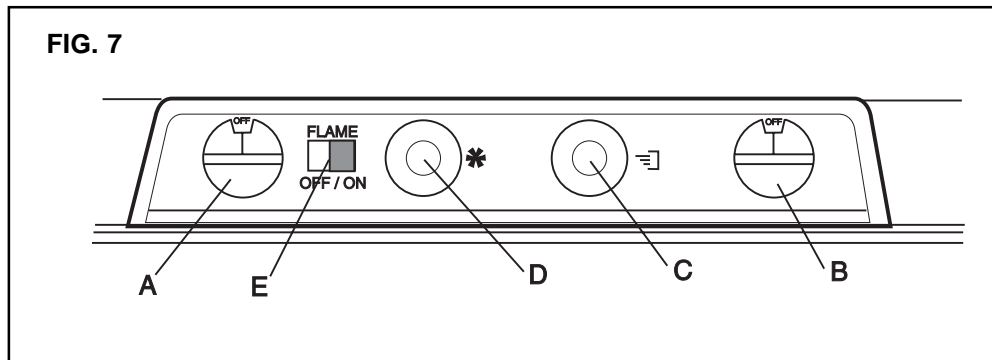

FIG. 8

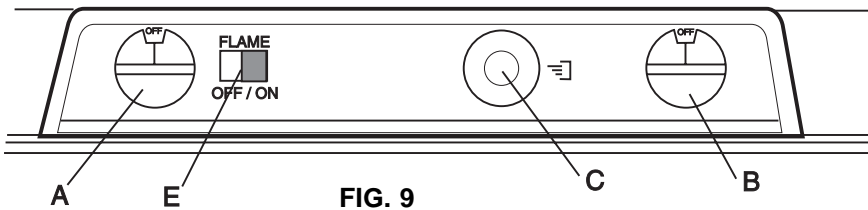
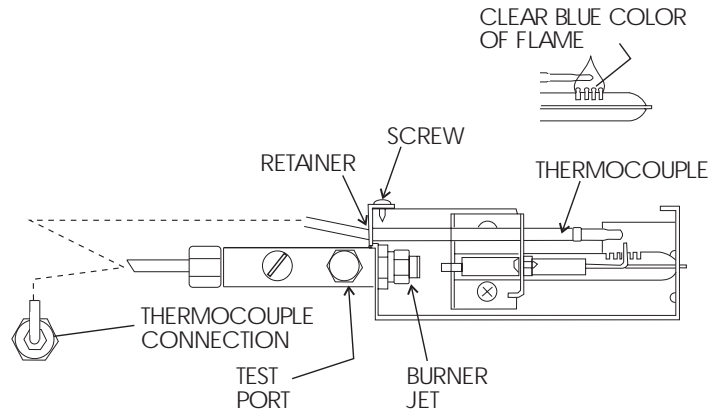

FIG. 9

REFRIGERATORS WITH AUTOMATIC REIGNITORS (RM2552 & RM2553)

- Start the refrigerator according to the instructions for Gas Operation with Automatic Reignitor. See *Section B. Operating Instructions, Item 3, Gas Operation*.
- Check that the gas flame is lit by observing flame indicator (E). (See FIG. 9).
- Close the gas valve by turning the knob "A" back to the "OFF" position. (See FIG. 9)
- Wait one minute, then disconnect the 12 volt DC power. (See FIG. 6 and 6A).
- Remove burner cover plate. (See FIG. 6 and 6A). Open the gas valve by turning knob "A" to the "GAS" position without pushing button "C". (See FIG. 9). The reignitor should not be sparking. Apply commercial leak-check bubble solution to the burner jet. (See FIG. 8). Be careful not to damage burner jet.
- No bubbles should appear at the opening of the burner jet. Bubbles indicate a defective gas safety shutoff and service is required.
- If no bubbles were present at the burner jet, rinse the orifice with water. Replace the burner cover plate. Reconnect the 12 volt DC power supply to the refrigerator. See Section A. Installation, Item 11, 12 Volt DC Connection. Start the refrigerator by following the instructions for gas operation with automatic reignitor. Normal gas operation should now return. Allow the burner to operate a minimum of five minutes.

10. 120 VOLT AC CONNECTION

The refrigerator is equipped with a three-prong (grounded) plug for protection against shock hazards and should be plugged directly into a properly grounded three-prong receptacle. DO NOT cut off or remove the grounding prong from this plug. The free length of the cord is 2 feet and therefore recommended that the receptacle be located to the left side of the refrigerator (viewed from the rear) and approximately 6 inches from the floor. (See FIG. 10). This allows easy accessibility through the vent door. The cord should be routed to avoid contacting the burner cover, flue cover, or any other components that could damage the cord insulation.

FIG. 10

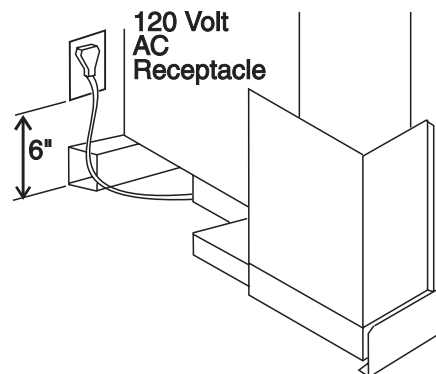

! WARNING

DO NOT use a flame to check for leaks.



11. 12 VOLT DC CONNECTION

2-WAY REFRIGERATOR MODELS

On 2-way refrigerator model **RM2552**, DC must be connected to the refrigerator to provide power for operation of the automatic reignitor. On this unit there is one terminal block marked 12 volts, located on the back of the refrigerator cabinet. (See FIG. 6A).

Reignitor Circuit Maximum Fuse / Minimum Wire Size
3 amps / 14 AWG

3-WAY REFRIGERATOR MODELS WITH AUTOMATIC REIGNITOR

On 3-way refrigerator models with automatic reignitors, there are two terminal blocks for DC. The DC terminal block on the back of the refrigerator cabinet is for the reignitor; and the DC terminal block located under a plastic cover on the back of the refrigerator is for the refrigerator heater. See FIG. 6A.

The refrigerator must be connected by a separate circuit to the battery with two wires of adequate capacity to avoid voltage drop when the DC heater is being operated. The wire gauge should be chosen with consideration to the length; refer to the Table below for wire size. The DC circuit must be fused; refer to the Table for fuse size.

MAXIMUM TOTAL CONDUCTOR WIRE LENGTH
(In Feet and Meters)

AWG	RM2453	RM2553
14	9FT. 2.7m	7FT. 2.1m
12	15FT. 4.6m	12FT. 3.6m
10	25FT. 7.6m	19FT. 5.8m
8	40FT. 12.2m	31FT. 9.5m
Max. Fuse Size	15 amps	20 amps

NOTE: The refrigerator Model RM2452 does not have an automatic reignitor. The 3-way model has only one 12 volt DC terminal block located on the back of the refrigerator.

DO NOT use the body or chassis of the vehicle as a substitute for either of the two conductors. **DO NOT** connect any other electrical equipment or lighting to the refrigerator circuit.

! CAUTION

DO NOT operate the refrigerator on 12 volt DC when the vehicle is parked. The amperage draw of the 12 volt DC heating element can discharge a battery in a very short time. The installation of a 12 volt DC operated refrigerator requires a relay to be installed on the tow vehicle or in the caravan. The relay will automatically shut off the 12 volt DC power to the refrigerator when the ignition is turned off. (See FIG. 11).

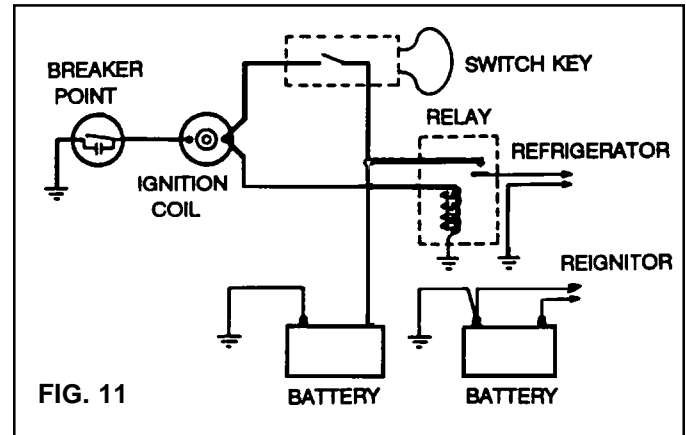

12. CHANGING DOOR SWING TO OPPOSITE SIDE

The refrigerator is equipped with convertible doors. To change the door swing, consult the parts manual for the Conversion Kit Part Number. For further information, please contact the Dometic Corporation listed on the front page.

13. INSTRUCTION FOR INSTALLING DOOR PANEL

The refrigerator is normally delivered without the door panels. Before starting the mounting work, check that the panel dimensions are in compliance with those given in the Table on this page and the instructions are read thoroughly. When mounting the panel, proceed as follows. (See FIG. 12)

- A. Remove the trim strip from the bottom/top of door by

PANEL DIMENSIONS
MAX. THICKNESS 5/32" (4 mm)

Refr. Models	HEIGHT		WIDTH		
	MAX.	MIN.	MAX.	MIN.	
RM2452/2453 upper	mm	32-11/16	32-5/8	20-11/16	20-9/16
	inch	831	828	526	522
RM2552/2553 upper	mm	38-7/8	38-3/4	20-11/16	20-9/16
	inch	987	984	526	522

taking out the 3 screws. See FIG. 8.

- B. Pullout the 2 pins in the end frame of the door. See FIG. 8.
- C. Slide panel into grooves on vertical edges of the door until it slips into the groove on the opposite end of door.
- D. Replace pins removed in Step B.
- E. Replace trim strip and screws.

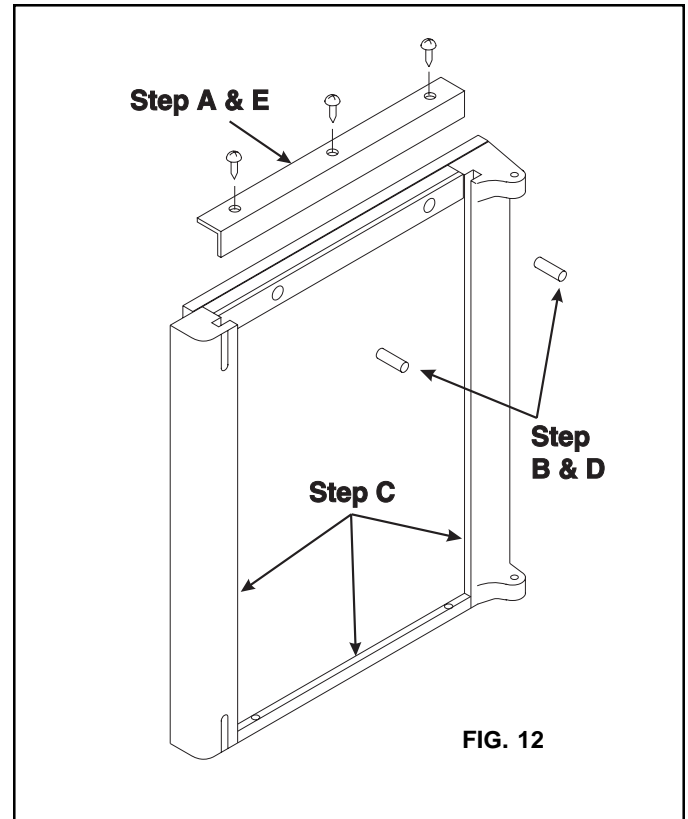

SECTION B. CERTIFIED VENT SYSTEM KITS

REFRIGERATOR MODEL	KIT NO.	COMPONENTS	PART NO.
RM2452 RM2453 RM2552 RM2553	OPTION #1	ROOF BASE ROOF COVER LOWER SIDE VENT	3103633.XXX * 3103634.XXX * 3102277.XXX *
	OPTION #2	UPPER SIDE VENT LOWER SIDE VENT	8302113XX 3102277.XXX
	OPTION #3-B	POWER VENT ASM. UPPER SIDE VENT LOWER SIDE VENT	3104131.002 ** 8302113XX 3102277.XXX
<p>* Fill in "XXX" with color code numbers. For color codes, contact your supplier. ** Alternate instructions forwarded with the Ventilator Kit.</p>			

SECTION C. OPERATING INSTRUCTIONS

! WARNING

Most LP gas appliances used in recreational vehicles are vented to the outside of the vehicle. When parked close to a gasoline pump, it is possible that the gasoline fumes could enter this type of appliance and ignite from the burner flame, CAUSING A FIRE OR AN EXPLOSION.

1. IMPORTANCE OF LEVELING A REFRIGERATOR

In an absorption refrigerator system, ammonia is liquefied in the finned condenser coil at the top of the refrigerator. The liquid ammonia then flows into the evaporator (inside the freezer section) and is exposed to a circulating flow of hydrogen gas, which causes the ammonia to evaporate, creating a cold condition in the freezer.

The tubing in the evaporator section is specifically sloped to provide a continuous movement of liquid ammonia downward by gravity through this section. If the refrigerator is operated when it is not level and the vehicle is not moving, liquid ammonia will accumulate in sections of the evaporator tubing. This will slow the circulation of hydrogen and

ammonia gas, or in severe cases, completely block it, resulting in a loss of cooling.

Any time the vehicle is parked for several hours with the refrigerator operating, the vehicle should be leveled to prevent this loss of cooling. The vehicle needs to be leveled only so it is comfortable to live in (no noticeable sloping of floors or walls).

When the vehicle is moving, the leveling is not critical as the rolling and pitching motion of the vehicle will pass to either side of level, keeping the liquid ammonia from accumulating in the evaporator tubing.

2. CONTROLS

FIG. 13

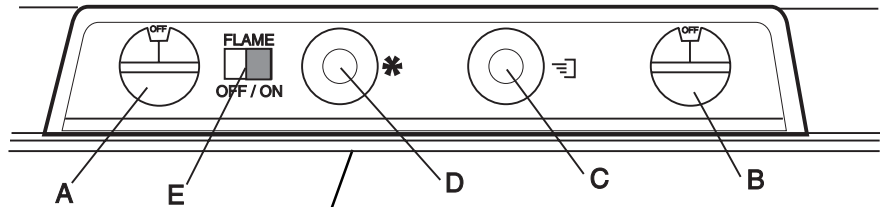

REFRIGERATORS WITH
PIEZO IGNITORS:
RM2452 AND RM2453

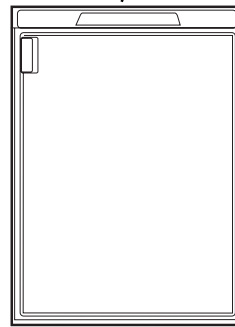

LEGEND:

- A Energy Selector Knob
- B Thermostat Knob
- C Flame Failure Safety Valve Push Button
- D Piezo Ignitor
- E Flame Indicator

FIG. 14

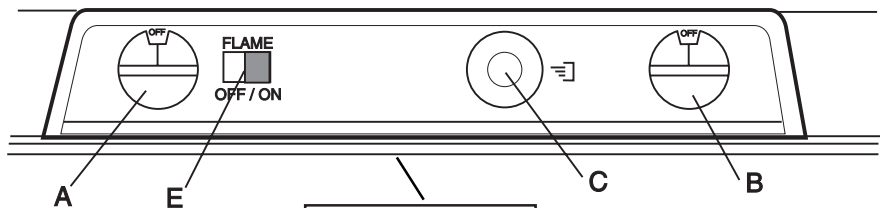

REFRIGERATORS WITH
AUTOMATIC IGNITION:
RM2552 AND RM2553

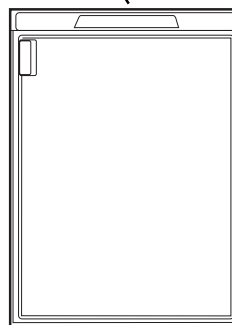

3. GAS OPERATION

A. REFRIGERATORS WITH PIEZO IGNITOR (RM2452 & RM2453)

1. To start the refrigerator, turn knob "A" to the "GAS" position. (See FIG. 13).
2. Turn the thermostat knob "B" one-quarter (1/4) of a turn from the "OFF" position. (See FIG. 13)
3. Push button "C", push button "D" for the piezo ignitor several times to light the burner. This can be observed on the flame indicator "E", on the refrigerator. (See FIG. 13).
4. After the flame lights, continue to hold button "C" for an additional ten (10) seconds. Release the button "C" and check the flame indicator "E" to make sure the burner does not go out. If the burner goes out, repeat the lighting procedure Steps A through D.
5. To shut off the refrigerator, turn knob "A" to the "OFF" position.

A. REFRIGERATORS WITH AUTOMATIC REIGNITORS (RM2552 AND RM2553)

1. To start the refrigerator, turn knob "A" to the "GAS" position. (See FIG. 14)
2. Turn the thermostat knob "B" one-quarter (1/4) of a turn from the "OFF" position. (See FIG. 14).
3. Push button "C" in until it bottoms out – and hold. When flame indicator "E" shows the flame is on, hold push button "C" an additional 15 seconds. Release button "C". If the flame indicator "E" starts to move toward off, repeat Steps A through C. (See FIG. 14). Should flame blow out, the reignitor will automatically relight the flame.

NOTE: After changing an LP tank, or after a long shut-off period, the gas line is likely to be filled with air. You may have to repeat the lighting procedure several times to purge the air out of the gas lines.

4. ELECTRIC OPERATION

- A. Check to be sure the power cord is properly connected to the power supply. (See FIG. 10). If the refrigerator is equipped for 12 volt DC operation, the tow vehicle or caravan engine should be running to prevent discharging the battery.
- B. Turn knob "A" to the position marked "ELEC" for 120 volt AC operation or "12V" for 12 volt DC operation. (See FIGS. 13 & 14).
- C. Turn the thermostat knob "B" one-quarter (1/4) of a turn from the "OFF" position.
- D. To shut off the refrigerator, turn knob "A" to the "OFF" position.

5. THERMOSTAT

The refrigerator is equipped with a thermostat that can be adjusted by turning knob "B" to a different setting to maintain the desired cabinet temperature. (See FIGS. 13 & 14).

- A. **"OFF" Setting of the Thermostat:** In gas operation, the thermostat closes its main valve and the burner runs continuously at the bypass rate or pilot. In electrical operation, the contacts in the thermostat are open and the heating elements are off.
- B. **"MAX" Setting of the Thermostat:** In gas operation, the thermostat allows the burner to remain on high flame continuously. In electric operation, the heating element is "ON" continuously.
- C. The thermostat can be adjusted between "MAX" and "OFF" to obtain the desired cabinet temperature. The closer the knob is to "MAX", the colder the cabinet temperature. The closer the knob is to "OFF", the warmer the cabinet temperature.

When the thermostat reaches the set temperature, it will cut the burner back to bypass or, in electric operation, shut off the heating element.

The setting of the thermostat is not critical, but we recommend it be adjusted to maintain a dry frost on the cooling fins. Adjust the thermostat knob closer to "MAX" when the outside temperature becomes warm.

4. HOW TO USE THE REFRIGERATOR

A. FOOD STORAGE COMPARTMENT

The food storage compartment is completely closed and unventilated, which is necessary to maintain the required low temperature for food storage. Consequently, foods having a strong odor or those that absorb odors easily should be covered. Vegetables, salads, etc. should be covered to retain their crispness. The coldest positions in the refrigerator are under the cooling fins and at the bottom of the refrigerator. The warmer areas are on the upper door shelves. This should be considered when placing different types of food in the refrigerator.

B. FROZEN FOOD STORAGE COMPARTMENT

Quick frozen soft fruits and ice cream should be placed in the coldest part of the compartment which is at the bottom of the aluminum liner. In models with a shelf, place these foods on or just below the freezer shelf. Frozen vegetables, may be stored in any part of the compartment.

This compartment is not designed for deep or quick freezing of food. Meat or fish, whether raw or prepared, can be stored in the frozen food storage compartment provided they are precooled first in the refrigerator. They can be stored about three times longer in the frozen food compartment as compared to the fresh food compartment. To prevent food from drying out, keep it in covered dishes, containers, plastic bags or wrapped in aluminum foil.

C. ICE MAKING

Ice cubes can be made in the ice tray placed in the freezer compartment. The tray should be filled with water to within 1/4" (5mm) from the top. For faster ice making, the tray should be placed in direct contact with the freezer shelf.

To release the ice cubes, seize the tray with both hands and twist the tray. Cubes not required should be replaced in the tray. Refill the tray with water and replace the tray on the freezer shelf.

Ice making is accelerated if the thermostat knob "B" is turned to the "MAX" setting. It is a good idea to do this a few hours before the anticipated need for ice, but be sure to move the thermostat back to normal setting, usually about mid-setting when the ice is formed. Food in the lower compartment may be frozen if the setting is left on "MAX" position.

D. DEFROSTING

Shut off the refrigerator by turning knob "A" to "OFF" position. Empty the refrigerator, leaving the drip tray under the finned evaporator. Leave the cabinet and freezer doors open. Defrosting time can be reduced by filling the ice tray with hot water and placing it on the freezer shelf. When all the frost has melted, empty the drip tray and dry the interior of the refrigerator with a clean cloth. Replace the drip tray and ice tray. Replace all the food and set the thermostat to its normal position.

DO NOT use a hot air blower. Permanent damage could result from warping the metal or plastic parts. **DO NOT** use a knife or an ice pick, or other sharp tools to remove frost from the freezer shelf. They can create a leak in the ammonia system.

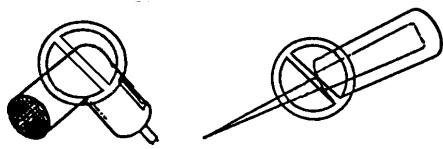

When all frost is melted, dry the interior of the refrigerator

with a clean cloth. Replace all food and set thermostat to the COLDEST temperature setting for a few hours. Then reset the thermostat to the desired setting, usually at mid-setting.

NOTE: On these models the drip tray/cup is on the rear side of the refrigerator. (See FIG. 6)

Put the plastic drain tube in a watertight bucket or container (access through louvered service panel on the outside of the vehicle). As the frost melts, the water will flow into the container. When all the frost has melted wipe up the excess moisture and empty the accumulated water from the bucket. Replace the drain tube to its original position.

E. CLEANING

Cleaning the refrigerator is usually done after it is defrosted or put into storage. To clean the interior liner of the refrigerator, use lukewarm weak soda solution. Use only warm water to clean the finned evaporator, gasket, ice trays and shelves. **NEVER use strong chemicals or abrasives to clean these parts as the protective surfaces will be damaged. It is important to always keep the refrigerator clean.**

F. SHUT-OFF (STORAGE PROCEDURE)

To shut off the refrigerator, turn knob "A" to "OFF" position. If the refrigerator will not be in operation for a period of weeks, it should be emptied, defrosted, cleaned and the doors left ajar. The ice tray should also be dried and kept outside the cabinet.

Most LP-Gas appliances used in recreational vehicles are vented to the outside of the vehicle. When parked close to a gasoline pump, it is possible that gasoline fumes could enter this type of appliance and ignite the burner flame CAUSING A FIRE OR AN EXPLOSION.

FOR YOUR SAFETY, it is recommended that all LP-Gas appliances which are vented to the outside shut off when refueling.

(Section D. Maintenance & Service, continued on next page . . .)

SECTION D. MAINTENANCE AND SERVICE

Tips for the Service Technician

The user should be aware of service that must be done on a regular schedule to keep the refrigerator operating properly. The service should only be performed by a qualified technician who is familiar with LP gas systems and refrigerators.

1. PERIODIC MAINTENANCE

To keep your Dometic refrigerator operating efficiently and safely, periodic inspection and cleaning of several components is recommended once or twice a year.

A. It is important to keep the area at the back of the refrigerator clear. Check the lower vent, upper vent and the area between these openings for any obstructions such as bird/insect nests, spider webs, etc. It is important to keep the refrigerator area free from combustible material, gasoline and other flammable liquids or vapors.

NOTE: The following maintenance is required once or twice a year, but should only be done by a qualified serviceman who is familiar with LP gas systems and refrigerators.

B. Check all connections in the LP gas system (at the back of the refrigerator) for gas leaks. The LP gas supply must be turned on. Apply a noncorrosive bubble solution to all LP gas connections. The appearance of bubbles indicates a leak and should be repaired immediately by a **QUALIFIED SERVICEMAN WHO IS FAMILIAR WITH LP GAS SYSTEMS AND REFRIGERATORS.**

B. Check all connections in the LP gas system (at the back of the refrigerator) for gas leaks. The LP gas supply must be turned on. Apply a noncorrosive bubble solution to all LP gas connections.

! WARNING

DO NOT USE A FLAME TO CHECK FOR GAS LEAKS.



C. Check burner flame for proper appearance. The flame should be light blue with no yellow at the tip. (See FIG. 15)

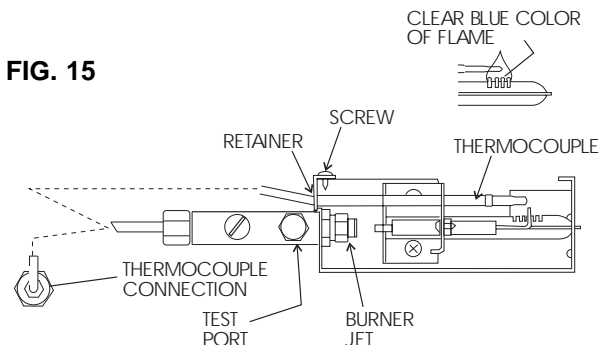

D. CHECK GAS PRESSURE

The LP gas pressure should be checked and readjusted if necessary. The correct operating pressure is eleven inches of water column. The correct place to take the pressure reading is at the test port just ahead of the main orifice. (See FIG. 15)

E. CLEANING FLUE TUBE, BURNER & BURNER JET

NOTE: Before working on the refrigerator, make sure that 120 volt AC and optional 12 volt DC leads are disconnected. Shut off Gas valve.

THE BURNER AND BURNER JET:

The color of the flame should be clear blue of the slots of the burner (FIG. 15).

Once or twice a year, depending upon use, clean and adjust the burner assembly. Proceed as follows:

1. Remove protection plate from the burner housing.
2. Disconnect the wire from the high voltage electrode.
3. Remove the burner mounting screws and remove the burner assembly.
4. Clean the burner tube with a brush. Blow with compressed air.
5. Remove the burner jet. Soak the jet in wood alcohol and blow it out with compressed air. **NEVER** use a wire pin to clean the burner jet.

! CAUTION

DO NOT use a wire or pin when cleaning the burner jet as damage can occur to the precision opening. This can cause damage to the refrigerator or create a fire hazard.

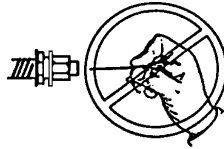

6. Remove the flue cap from top of flue tube and lift out the wire and spiral baffle. Clean the flue from the top, using a flue brush. Replace spiral baffle and flue cap.
7. Remove all loose scale, soot, etc. from area below the flue pipe. (See FIG.15).
8. Reassemble.
9. Be careful that the end of the burner fits into the slot on the bracket. The slots of the burner must be centrally located under the flue tube.

10. The gas fittings on the refrigerator need to be checked for leaks. Turn on the gas supply at the shut-off valve. Apply a noncorrosive bubble solution to the fitting and observe for leaks. The safety valve will not allow gas pressure to any connections between it and the burner jet. These fittings must be checked before burner is lighted.

! WARNING

The safety shut-off must be manually depressed to allow gas pressure to flow to the burner jet. Be sure to apply the leak check solution before depressing the safety shut-off. **DO NOT** allow any open flame, sparks, smoking, etc., in the area of the test. **DO NOT** depress safety shut-off for over 30 seconds.

11. Allow 10 minutes for the LP gas to leave the burner area. Reconnect the 12 volt DC power. Light the burner per *Section C, Operating Instructions, Item 3, Gas Operation*. Allow burner to run 5 minutes.
12. Connect the power cord to the 120 volt AC wall outlet.

- F. Check LP gas safety shut-off. See *Section A, Installation, Item 9, Testing LP Gas Shut-Off*.

G. THE ELECTRODE

For a proper ignition function it is necessary to keep the electrode insulation dry and free from dirt. The gap between burner tube and electrode shall be a maximum of 3/16" (5mm) and a minimum of 1/8" (3mm). (See FIG. 16).

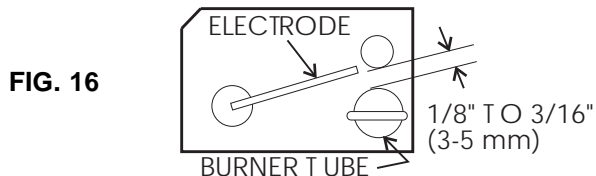

NOTE: Avoid spraying water through the refrigerator's vents while washing your RV.

2. TROUBLESHOOTING

THE REFRIGERATOR DOES NOT COOL PROPERLY

- A. Burner jet clogged. Remove the burner jet. Soak the jet in wood alcohol and blow it out with compressed air. Do not use a wire or pin to clean the burner jet.
- B. Refrigerator is not level.
- C. Flame has gone out.
Remedy: 1) Gas bottle is empty - refill. 2) The tip of the flame failure safety device is not heated enough by flame. 3) Clogged bypass screw - clean or exchange it.
- D. Venting problem.
Restriction in air flow across cooling unit.
- E. Heavy frost buildup on evaporator fins.
Defrost.
- F. Flue baffle not inserted properly in flue tube.
- G. Improperly set thermostat.
See paragraph on thermostat. In hot weather the setting should be closer to the "MAX" than usual.
- H. Burner dirty.
Clean.
- I. Burner damaged.
Replace.
- J. LP gas pressure low at burner.
Set main regulator so the pressure does not drop below 11 inches water column at pressure tap.
- K. Burner not located properly under flue tube.
Relocate.

ODOR FROM FUMES

Causes and Remedies:

- A. The flame touches side of boiler due to dislocation of the burner. Relocate. Burner dislocation may also cause smoke and discoloring of walls and ceiling.
- B. Burner damaged. Replace.
- C. The flue tube is dirty. Clean flue as follows:
Cover burner and burner jet. Remove the flue cap from the top of the flue tube and lift out the wire and spiral baffle. Clean the flue from the top using a flue brush. Clean the spiral baffle. Replace the spiral baffle and flue cap.

All the instructions are to be followed closely. The refrigerator is quality-guaranteed. However, we are not responsible for any failures caused by improper adjustments and unfavorable installation conditions.

CONTACT AN AUTHORIZED SERVICE CENTER FOR PARTS AND REPAIRS AS NEEDED.