



INSTALLATION AND OPERATING INSTRUCTIONS

REFRIGERATOR FOR ELECTRIC OPERATION

NDE1402

NEW DIMENSIONS



Contents:

	Page
Installation	4
Operating Instructions	8
Maintenance & Service	11

FOR YOUR SAFETY

Do not store or use gasoline or other flammable vapors and liquids in the vicinity of this or any other appliance.

Pour votre sécurité

Ne pas entreposer ni utiliser de l'essence ni d'autres vapeurs ou liquides inflammables à proximité de cet appareil ou de tout autre appareil.

WARNING: Improper installation, adjustment, alteration, service or maintenance can cause injury or property damage. Refer to this manual. For assistance or additional information consult a qualified installer, service agency or the supplier.

Avertissement: Une installation, un réglage, une modification, une réparation ou un entretien non conforme aux normes peut entraîner des blessures ou des dommages matériels. Lisez attentivement le mode d'emploi fourni avec l'appareil. Pour obtenir de l'aide ou des renseignements supplémentaires, consultez un installateur ou un service d'entretien qualifié ou le fournisseur.



USA
Service Office
Dometic Corporation
2320 Industrial Parkway
Elkhart, IN 46515
Phone: 574-294-2511

Corporate Office
2320 Industrial Parkway Elkhart, IN 46515

For Service Center Assistance
Call: 800-544-4881

CANADA
Dometic Distribution Inc.
866 Langs Drive
N3H 2N7 Canada
Phone: 519-653-4390

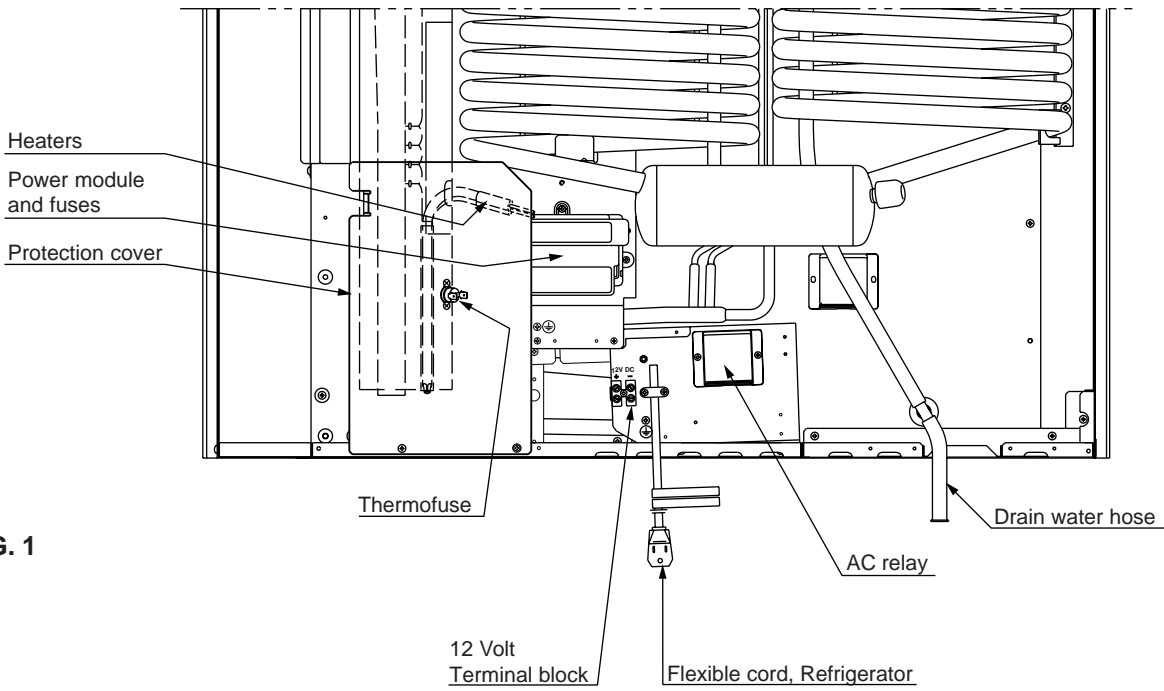

FIG. 1

Refrigerator control panel

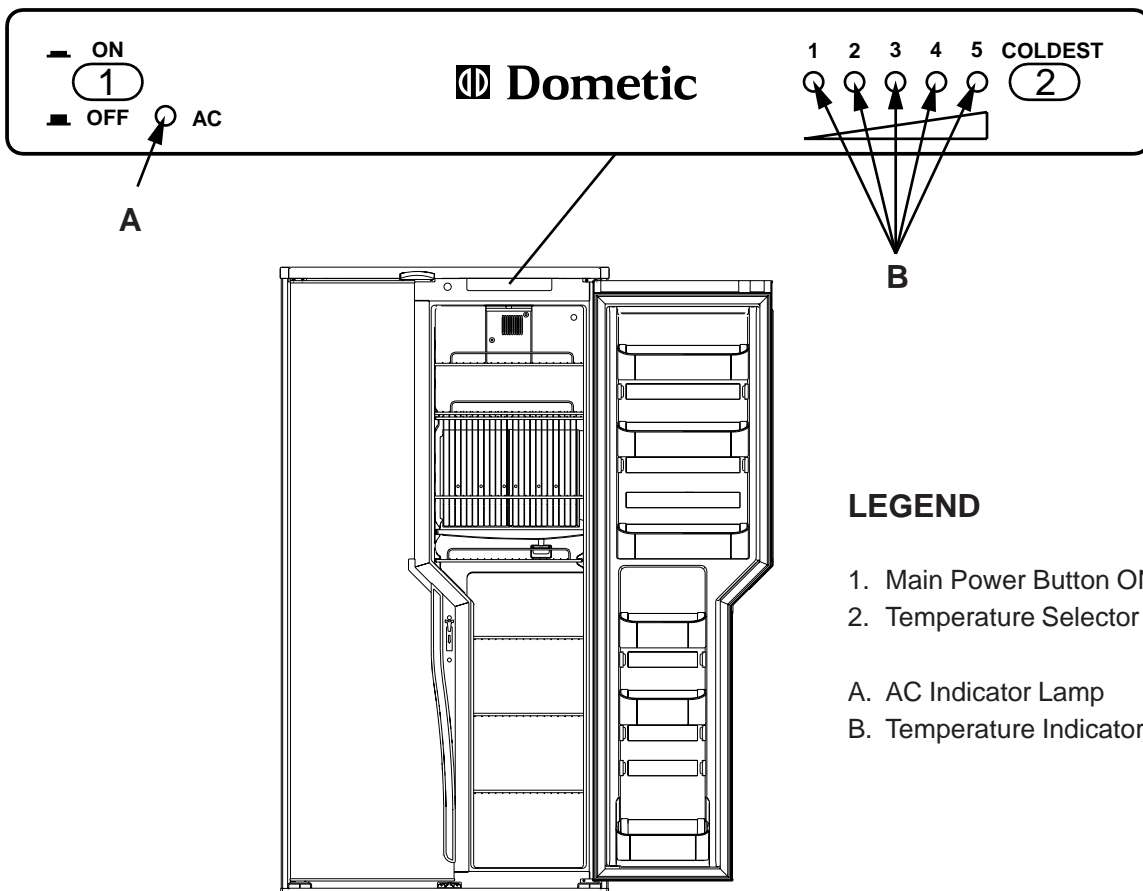

FIG. 2

INSTALLATION

GENERAL INSTRUCTION

This appliance is designed for storage of foods and storage of frozen foods and making ice.

This appliance is certified under the latest edition of ANSI Z21.19•CSA 1.4 Refrigerators using gas fuel.

The installation must conform with local codes, or in absence of local codes, the following standards as applicable.

In the U.S. the installation must conform with:

1. Recreational Vehicles Code, ANSI A119.2 (latest edition)
2. Manufactured Home Construction and Safety Standard, Title 24 CFR, Part 3280.

If an external electrical source is utilized, the refrigerator, when installed, must be electrically grounded in accordance with local codes or, in the absence of local codes, the National Electrical Code, ANSI/NFPA 70 - (latest edition).

In CANADA, the installation must conform with:

1. CSA Z240 RV Series, Recreational Vehicles.
2. Current CSA Z240.4, Gas-equipped Recreational Vehicles and Mobile Housing.

If an external electrical source is utilized, the refrigerator, when installed, must be electrically grounded in accordance with local codes or, in the absence of local codes, the Canadian Electrical Code, CSA C22.1, Parts I and II - (latest edition).

VENTILATION

The installation shall be made in such a manner as to provide necessary air circulation over the cooling unit. Openings for air supply shall have a minimum dimension of not less than 1/4 inch.

Proper installation requires one lower fresh air intake and one upper exhaust vent. The ventilation kits shown in this instruction manual have been certified for use with the refrigerator models listed in the table. For *“Certified Vent System Kits”* see page 13.

The ventilation kits must be installed and used without modification. The lower vent of the recommended kits is provided with proper size openings.

The flow of ventilating air must not be obstructed.

The lower side vent is fitted with a panel, which provides an adequate access opening for ready serviceability off the refrigerator. This should be centered on the back of the refrigerator.

ELECTRICAL CONNECTION

120 Volts AC Connection

The refrigerator is equipped with a three-prong (grounding) plug for your protection against shock hazards and should be plugged directly into a properly grounded three-

prong receptacle. DO NOT cut or remove the grounding prong from this plug. The free length of the cord is 2 feet and therefore recommended that the receptacle be located to the right side of the refrigerator (viewed from the rear) and approximately 10 inches from the floor (see FIG. 3). This allows easy access through the vent door. The cord should be routed to avoid direct contact with the burner cover, flue cover or any other components that could damage the cord insulation.

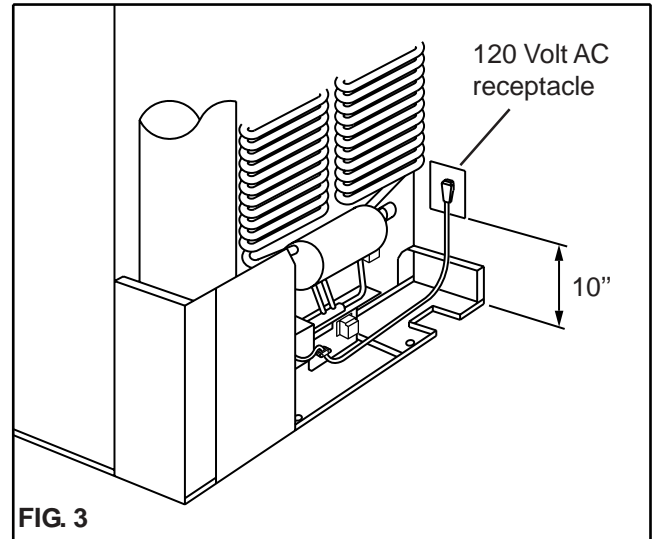

FIG. 3

12 Volts DC Connection

The refrigerator model NDE1402 require a continuous 12 volt DC supply to operate the control system. The connection is made to the positive (+) and negative (-) terminals of the terminal block on the back of the refrigerator. (See FIG. 1). Correct polarity must be observed when connecting to the DC supply.

Do not use the chassis or vehicle frame as one of the conductors. Connect two wires at the refrigerator and route to the DC supply.

The distance the current must travel from the battery to the refrigerator dictates the AWG wire size to be used. Should the wire be too small for the distance, a voltage drop will result.

Recommended wire sizes are shown below.

**MAXIMUM TOTAL CONDUCTOR WIRE LENGTH
(in feet and meters)**

Wire length	AWG
17 ft.	14
5 m	
27 ft.	12
8 m	

The wires from the battery to the refrigerator must be of large enough size to handle the load. The connections must be clean, tight and free from corrosion.

INSTALLING REFRIGERATOR IN ENCLOSURE

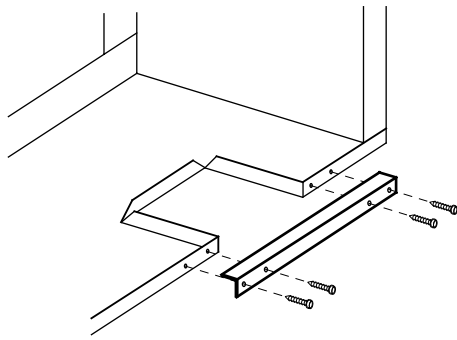

The transport support at the rear of the refrigerator can be removed if necessary for the installation of the refrigerator in the enclosure. (See figure above).

NOTE: DO NOT install the appliance directly on carpeting. Carpeting must be removed or protected by a metal or wood panel beneath the appliance, which extends at least full width and depth of the appliance.

Caution: Use care when installing the refrigerator. This refrigerator is equipped with the latest vacuum insulated panel technology. These insulating panels are located on the Top, Back, Bottom, Sides and Doors of the refrigerator.

If the surface is punctured, loss of insulation will occur, resulting in poor refrigerator performance.

NOTE: A wood strip must be in place across the upper opening of the enclosure. The top frame of the refrigerator will be anchored to the wood strip with screws, see FIG. 10.

The refrigerator must be installed in a substantial enclosure and must be level. When installing the refrigerator in the enclosure, all areas within the recess in which the refrigerator is installed must be sealed.

Make sure that there is a complete seal between the front frame of the refrigerator and the top, sides and bottom of the enclosure. A length of sealing strip is applied to the rear surface of the front frame for this purpose, see FIG. 4. The sealing should provide a complete isolation of the appliance's combustion system from the vehicle interior.

NOTE: Be careful not to damage the sealing strip when the refrigerator is put in place.

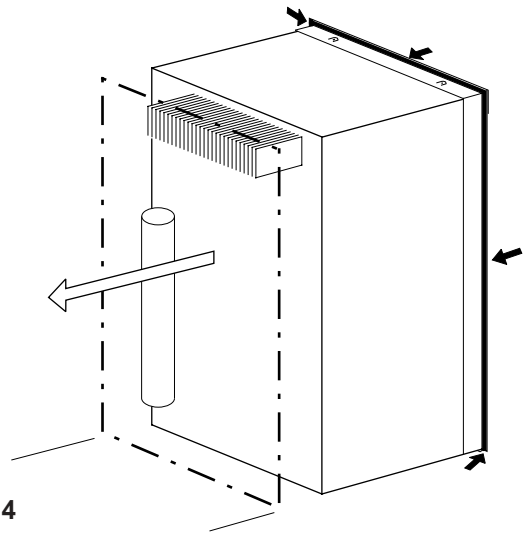

FIG. 4

Securing the Refrigerator

After the refrigerator is put in place, the refrigerator is to be secured in the enclosure with six screws (not included). The screws have to be installed in the following order:

STEP 1: Two screws installed through the front base, which includes the lower front strip installation.

The refrigerator is provided with a lower front strip (shipped as a loose part). The front strip is to be attached after the refrigerator is set into the cutout opening.

1. Install the lower front strip by sliding it under the bottom hinge plates, as shown in FIG. 5.
2. Secure the refrigerator and the lower front strip with two screws: One screw through each hinge. See FIG 6.

FIG. 5

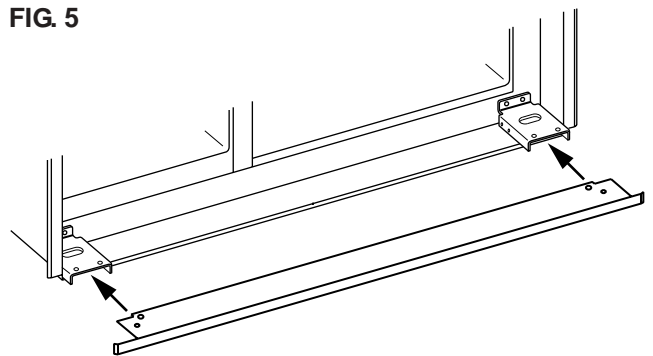
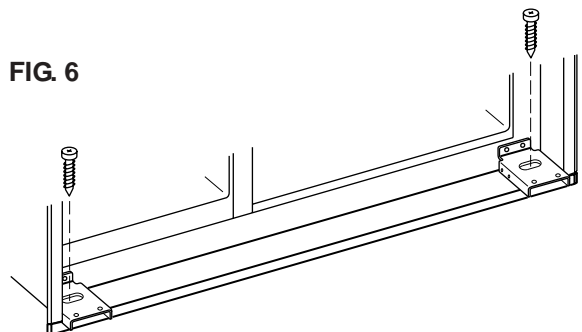

FIG. 6



Step 2: Two screws installed in the top frame.

Open the doors and fasten the refrigerator with two screws through the holes underneath the top decoration panel. See FIG. 7.

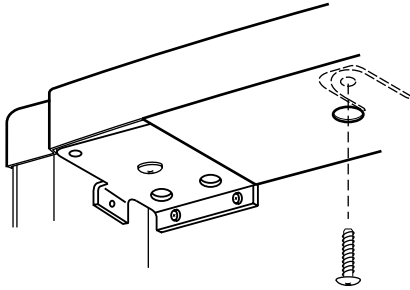

FIG. 7

Failure to follow the sequence in securing refrigerator in enclosure can cause leakage between the frame and cabinet.

Any space between the counter, storage area or ceiling and top of the refrigerator greater than 1-1/2 inches should be blocked. The heat produced at the rear of the refrigerator will become trapped in this space, making the top of the refrigerator hot and reduce the efficiency of the refrigerator.

Drain water hose

A hole must be drilled through flooring see FIG. 8. The hole must be drilled in the cut out opening of the base plate at the rear of the refrigerator. The installer MUST make sure that the hose does not kink when run through the floor. Seal around the hose that goes through the drilled hole. If a longer hose than supplied is required to get the water to drain outside of the vehicle, the installer will have to supply the extra length of hose.

STEP 3: Two screws installed in the rear base.

See FIG. 8.

FIG. 8

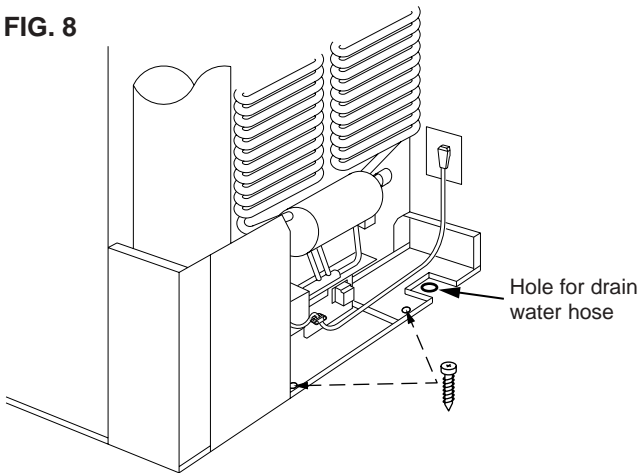

CERTIFIED INSTALLATION

Certified installations require one roof vent and one lower side vent.

For "Certified Vent System Kits" see page 13.

For further information contact your dealer or distributor.

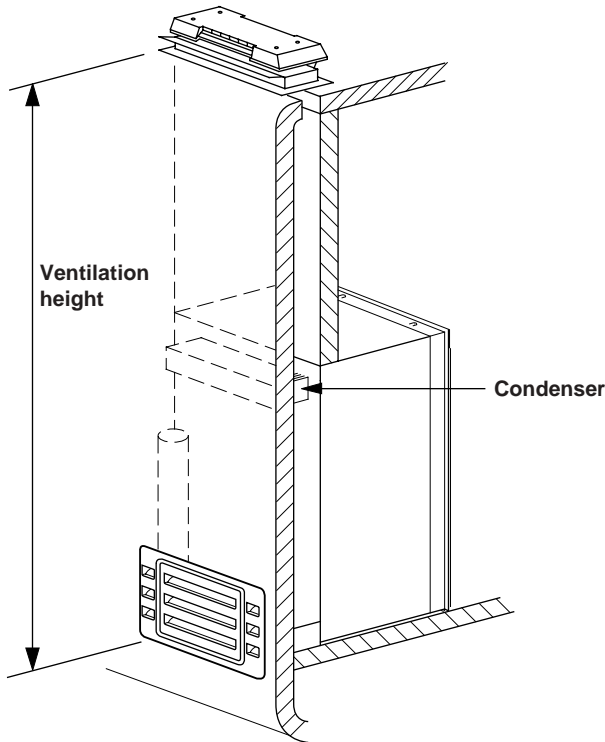

FIG. 9

LOWER VENT CUTOUT

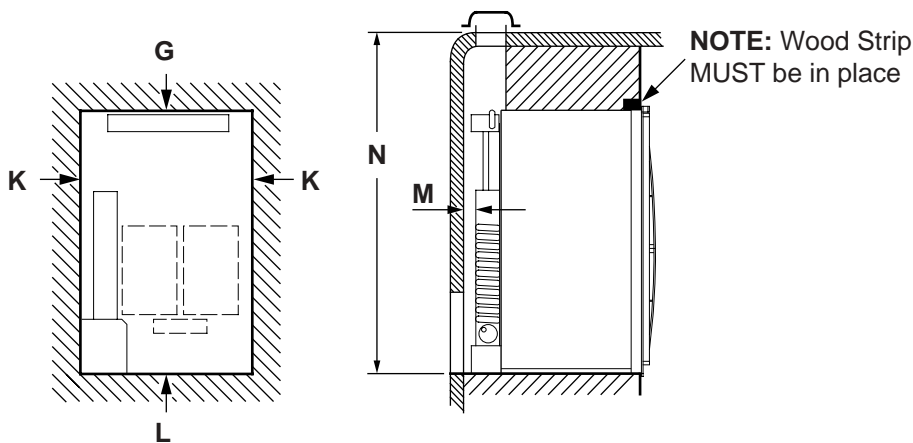

FIG. 10

METHODS OF INSTALLATION

The method of installation is shown in FIG. 9. It is essential that all maximum or minimum dimensions are strictly maintained as the performance of the refrigerator is dependent on adequate flow of air over the rear of the refrigerator.

NOTE: The upper vent should be centered over the condenser coil at the back of the refrigerator.

VENTILATION HEIGHTS

Installation with roof vent and lower side vent	Minimum ventilation heights in:	
Refrigerator	Inches	mm
NDE1402	69-1/8	1756

CLEARANCES

Minimum clearances in inches to combustible materials are:

- G: Top 0
- K: Side 0
- L: Bottom 0
- M: Rear 0
- N: See NOTE: Clearance "N" below.

NOTE: Clearance "M" is between the rearmost part of the refrigerator and the wall behind the refrigerator.

NOTE: Clearance "N" is the distance between the bottom of the lower vent to the roof material. For ventilation height, see table VENTILATION HEIGHTS See Figures 9, and 10.

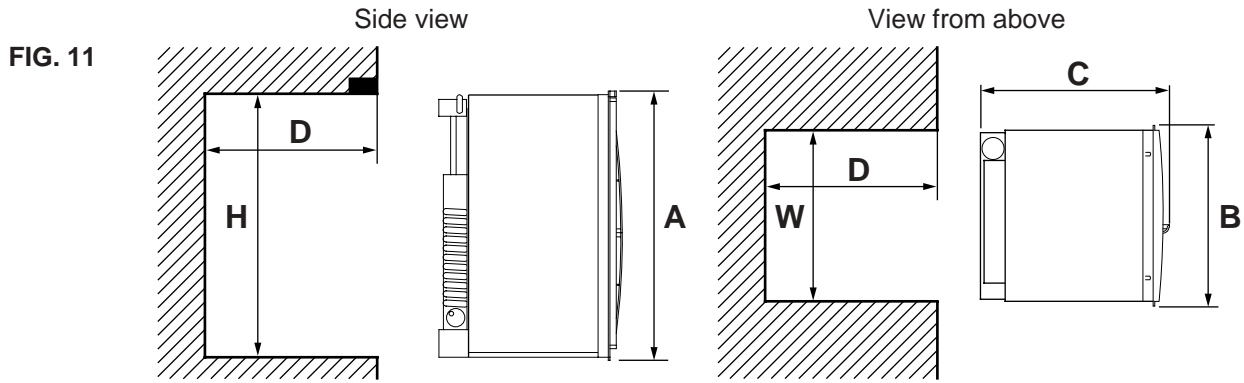

Refrigerator Model	Overall Dimensions			Recess Dimensions			
	Height A	Width B	Depth C	Height H	Width W	Depth D	
NDE1402	inch	64-17/64	33-11/16	29-5/8	63-3/16	32-3/4	26-1/16
	mm	1632	855	752	1605	832	662

This method of installation and these clearances will give you adequate space for service and proper installation.

OPERATING INSTRUCTIONS

IMPORTANCE OF LEVELING A REFRIGERATOR

In an absorption refrigerator system, ammonia is liquefied in the finned condenser coil at the top rear of the refrigerator. The liquid ammonia then flows into the evaporator (inside the freezer section) and is exposed to a circulating flow of hydrogen gas, which causes the ammonia to evaporate, creating a cold condition in the freezer.

When starting this refrigerator for the very first time, the cooling cycle may require up to four hours of running time before the cooling unit is fully operational.

The tubing in the evaporator section is specifically sloped to provide a continuous movement of liquid ammonia, flowing downward by gravity through this section. If the refrigerator is operated when it is not level and the vehicle is not moving, liquid ammonia will accumulate in sections of the evaporator tubing. This will slow the circulation of hydrogen and ammonia gas, or in severe cases, completely block it, resulting in a loss of cooling.

Any time the vehicle is parked for several hours with the refrigerator operating, the vehicle should be leveled to prevent this loss of cooling. The vehicle needs to be leveled only so it is comfortable to live in (no noticeable sloping of floor or walls).

When the vehicle is moving, the leveling is not critical, as the rolling and pitching movement of the vehicle will pass to either side of level, keeping the liquid ammonia from accumulating in the evaporator tubing.

OPERATION

This refrigerator is designed to work on 120 volt AC. The refrigerator require a continuous 12 volt DC supply to operate the control system, the controls will work down to 9.6 volt DC.

DISPLAY PANEL

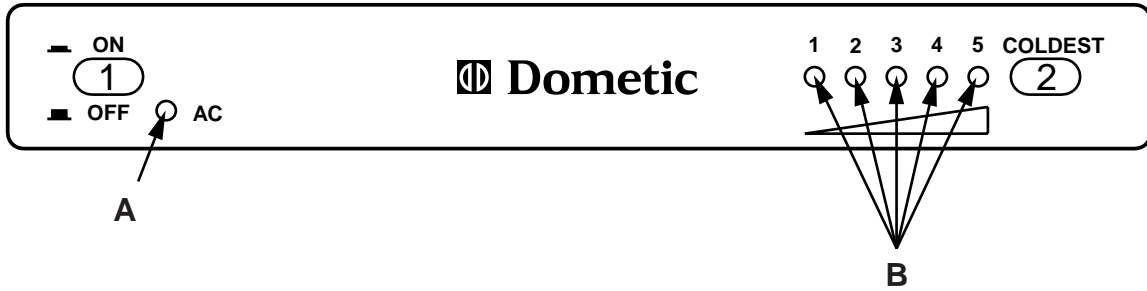

START UP INSTRUCTIONS

- A. A continuous 12 volt DC supply must be available for the electronic control to function.
- B. Press the main power ON/OFF button (1) to the DOWN position.
- C. Press the TEMPERATURE SELECTOR button (2) until the lamp at the desired setting is illuminated.

Note: Depending on ambient temperature, if the setting is left on in "COLDEST" position too long it may cause overfreezing.

TO SHUT OFF THE REFRIGERATOR

To shut off the refrigerator press the main power ON/OFF button (1) to the UP (OFF) position. This shuts off all DC power to the refrigerator, including the interior light.

DESCRIPTION OF OPERATING MODES

LIMP MODE OF OPERATION

This control system contains a feature where it will continue to operate the cooling system in the event of a failure of a major operating component. Two different modes of operation can occur in this category.

If for some reason the display module becomes non functional, the refrigerator will continue to operate and the temperature of the refrigerator will be maintained at the MID position within normal temperature tolerances. The power module will continually attempt to reestablish operation of the display module.

The second limp mode of operation will execute when a failure of the temperature sensing device or associated electronic circuitry occurs. If this should occur, the refrigerator will run continuously.

The refrigerator will continue to operate in this mode indefinitely or until a new sensor is installed and the system is reset.

HOW TO USE THE REFRIGERATOR

FOOD STORAGE COMPARTMENT

The food storage compartment is completely closed and unventilated, which is necessary to maintain the required low temperature for food storage. Consequently, foods having a strong odor or those that absorb odors easily should be covered. Vegetables, salads etc. should be covered to retain their crispness. The coldest positions in the refrigerator are under the cooling fins and at the bottom of the refrigerator. The warmer areas are on the upper door shelves. This should be considered when placing different types of food in the refrigerator.

When the refrigerator is heavily loaded, it will take a longer time to lower the temperature; therefore, to get maximum efficiency the refrigerator and food items should be precooled prior to loading. The shelves should not be covered with paper or plastic, and the food items should be arranged so air can circulate freely.

If you need more space in the refrigerator you can lift up the front of the second shelf from the top and push the shelf in, the shelf will fall down against the finned evaporator. This shelf cannot be relocated to a different position within the refrigerator.

The middle shelf is a sliding shelf, to slide out grasp the front of the shelf and pull forward. Push the shelf in to return to original position. This shelf cannot be relocated to a different position within the refrigerator.

The lower door shelf is designed for large containers or bottles (1/2-gallon milk or juice).

FROZEN FOOD STORAGE COMPARTMENT

Quick frozen soft fruits and ice cream should be placed in the coldest part of the compartment, which is on the top freezer shelf. Frozen vegetables, may be stored in any part of the compartment.

This compartment is not designed for deep or quick-freezing of food. Meat or fish, whether raw or prepared, can be stored in the frozen food storage compartment provided they are precooled first in the refrigerator. They can be stored about three times longer in the frozen food compartment as compared to the fresh food compartment. To prevent food from drying out, keep it in covered dishes, containers, plastic bags or wrapped in aluminum foil.

Total Refrigerated Volume 13.2 cu.ft.

Ice making

Ice cubes can be made in ice trays placed in the freezer compartment. For faster ice making, the trays should be placed in direct contact with the aluminum shelf.

Ice will be made more rapidly if the thermostat is set at its highest position. It is a good idea to do this a few hours before the anticipated need for ice, but be sure to move the thermostat back to normal setting, usually about mid setting when the ice is formed. Food in the fresh food compartment may be frozen if the setting is left on "COLDEST" position.

Freezer door

The freezer door has three wire door baskets for frozen food items, such as bagged vegetable.

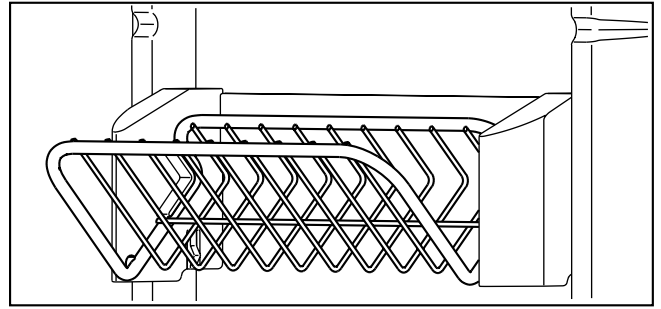

Freezer compartment

The freezer compartment has two sliding wire baskets for more convenient access to the frozen foods.

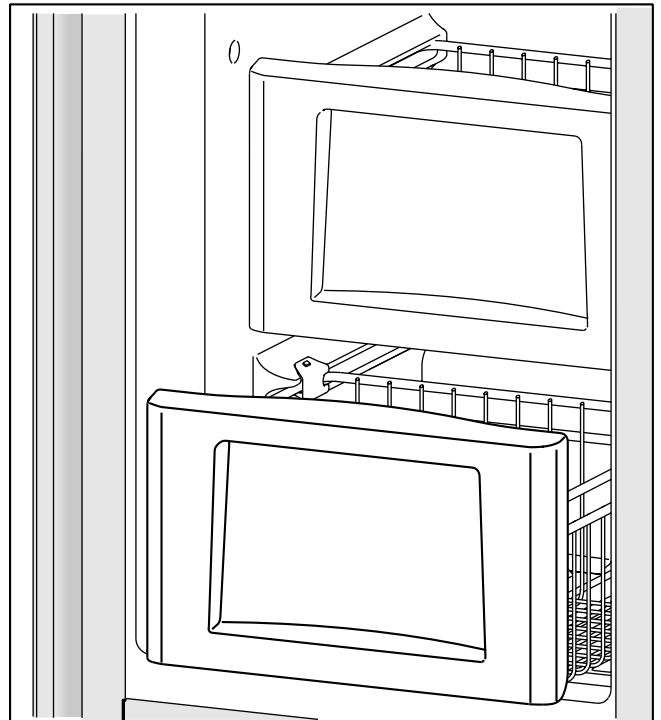

DEFROSTING

Shut off the refrigerator by pressing the main power ON/OFF button to the UP (OFF) position.

Empty the refrigerator, leaving the drip tray under the finned evaporator, and the cabinet and freezer doors open. Filling ice trays with hot water and placing them on the freezer shelves can reduce defrosting time.

When all the frost has melted, dry the interior of the refrigerator and freezer with a clean cloth. Replace all food and set the thermostat to the COLDEST temperature setting for a few hours. Then reset the thermostat to the desired setting, usually at mid setting.

! CAUTION

DO NOT use a hot air blower. Permanent damage could result from warping the metal or plastic parts. DO NOT use a knife or an ice pick, or other sharp tools to remove frost from the freezer shelves. They can create a leak in the ammonia system.

CLEANING

Cleaning the refrigerator is usually done after it is defrosted or put into storage. To clean the interior liner of the refrigerator, use lukewarm weak soda solution. Use only warm water to clean the finned evaporator, ice trays and shelves. NEVER use strong chemicals or abrasives to clean these parts, as the protective surfaces will be damaged. It is important to always keep the refrigerator clean.

SHUT OFF - STORAGE PROCEDURE

Shut off the refrigerator by pressing the main power ON/OFF button to the UP (OFF) position.

If the refrigerator will not be in operation for a period of weeks, it should be emptied, defrosted, cleaned and the doors left ajar. The ice trays should also be dried and kept outside the cabinet.

! WARNING

DO NOT store explosive substances in the refrigerator, such as cigarette lighter gas, gasoline, ether or the like.

NOTE: Sodium chromate is used for corrosion protection (less than 2-weight % of the coolant).

ELECTRIC EQUIPMENT

HEATERS

The heat necessary for the operation of an absorption cooling unit is supplied by an electric heater mounted in a pocket of the boiler system.

This model is equipped with a series connected twin heater.

To replace the heater proceed as follows:

1. Disconnect the wall plug, and the 12 volt wires.
2. Remove the protection cover see FIG. 1
3. Remove the power module cover see FIG. 1
4. Disconnect the heater leads.
5. With a pair of pliers unfold the lug holding the lid of the boiler casing and open the lid.
6. Remove some insulation wool so that the heater is accessible.
7. Turn and lift the heater out of its pocket.
8. Fit the new heater into the pocket.
9. Connect the leads and put on the power module cover.
10. Reset the insulation and close the lid of the boiler.
11. Replace the protection cover.

FUSES

This model is equipped with 2 fuses, one for the refrigerator control system and one for AC cartridge heater. (See table below).

To replace fuses proceed as follows.

1. Disconnect the wall plug, and the 12 volt wires.
2. Remove the power module cover. See FIG. 1.
3. Snap the fuse out of the fuse holder.
4. Fit a new fuse in to the fuse holder.
5. Replace the power module cover.

Control system	3 Amp
AC heater	5 Amp

MAINTENANCE & SERVICE

The user should be aware of service that must be done on a regular schedule to keep the refrigerator operating properly. The service should only be performed by a qualified technician who is familiar with refrigerators.

1. REFRIGERATOR REMOVAL

Before working on the refrigerator, make sure the AC voltage and DC voltage leads are disconnected. Loosen the screws anchoring the refrigerator to the enclosure and slide the refrigerator out of the compartment.

When replacing the refrigerator make sure that the sealing strips are properly positioned.

Replacement is the reverse of removal.

Refer to section **INSTALLATION**, page 4 to 8.

2. PERIODIC MAINTENANCE

To keep your Dometic refrigerator operating efficiently and safely, periodic inspection and cleaning of several components once or twice a year is recommended.

- A. It is important to keep the area at the back of the refrigerator clean. Check the lower vent, upper vent and area between these openings for any obstructions such as bird/insect nests, spider webs, etc. Clean the coils on the back of the refrigerator. Use a soft bristled brush to dust off the coils.

It is important to keep the refrigerator area free from combustible material, gasoline and other flammable vapors or liquids.

3. REPLACING A HALOGEN LAMP

! CAUTION

Turn off the refrigerator before replacing the lamp. Wear gloves as protection against hot lamp, broken glass and as protection of the new lamp.

Refrigerator

The lamp is located at the top of the refrigerator compartment.

To replace the lamp proceed as follows:

- unhook the tab on the lamp cover by pressing in with the thumb on the side of the lamp cover.
- remove the lamp cover.
- with gloves, pull out the lamp from the socket and replace it with a new **12V, 10-watt** halogen lamp base G4.
- replace the lamp cover by placing the two tabs into the corresponding slots of the lamp house and press the tab into place.

Freezer

The lamp is located on the right side of the freezer compartment.

To replace the lamp proceed as follows:

- unhook the tab on the lamp cover by pressing in with the thumb on the side of the lamp cover.
- remove the lamp cover.
- with gloves, pull out the lamp from the socket and replace it with a new **12V, 5-watt** halogen lamp base G4.
- replace the lamp cover by placing the two tabs into the corresponding slots of the lamp house and press the tab into place.

TROUBLESHOOTING

The Refrigerator Does Not Cool Properly

- A. Check level of refrigerator.
- B. Venting problem.
Restriction in air flow across cooling unit.
- C. Heavy frost buildup on evaporator fins.
Defrost.
- D. Improperly set thermostat.
(See section Operating Instructions, part Start Up Instructions.)
- E. FUSES
 1. Refrigerator AC Supply.
 2. Control system. See page 11, part Fuses.

If the refrigerator fails to work, check the following points before calling a service technician:

- that the fuses are intact
- that the power cord is plugged in
- that 12 volt DC is connected to the refrigerator

The refrigerator is equipped with an overheating protection.

An authorised service technician can check if it has been triggered or not.

NOTE: AVOID SPRAYING WATER THROUGH THE REFRIGERATOR VENTS WHILE WASHING YOUR RV.

All the above instructions are to be followed closely. The refrigerator is quality-guaranteed. However, we are not responsible for any failures caused by improper adjustments and unfavorable installation conditions. Contact service point or distributor service dept. for assistance.

SPARE PARTS

The following list is a list of commonly used parts, which should be available, if required, from your Dometic Service Center.

Part No.	Description
17 37 72-01/3	Heater, 120V, 420W (2x 60V, 210W)
385 04 52-01/6	Lamp cover
385 04 55-01/9	Halogen lamp, food compartment 12V, 10W base G4
385 04 55-02/7	Halogen lamp, freezer compartment 12V, 5W base G4
293 25 83-04/6	Doorshelf, 3 pieces (upper)
293 25 77-03/0	Doorshelf, 2 pieces
385 04 45-01/0	Doorshelf, (lower)
385 04 46-01/8	Doorshelf, 2 pieces freezer (upper)
385 04 42-01/7	Crisper, 2 pieces
293 26 58-01/2	Bottle holder, 5 pieces

Replacement Parts Suppliers: See page 1.

Contact an authorized service center for parts and repairs as needed.

CERTIFIED VENT SYSTEM KITS

REFRIGERATOR MODEL	KIT NO.	COMPONENTS	PART NO.
NDE1402	5A	Roof Base Roof Cover Lower Side Vent	3103633.XXX* 3103634.XXX* 3109349.XXX*
		Power Vent Asm.	3108705.744**
* Fill in "XXX" with color code numbers. For color codes, contact your supplier. ** Alternate instructions forwarded with the Ventilator Kit.			

For further information contact your dealer or distributor.

Positioning of shelves

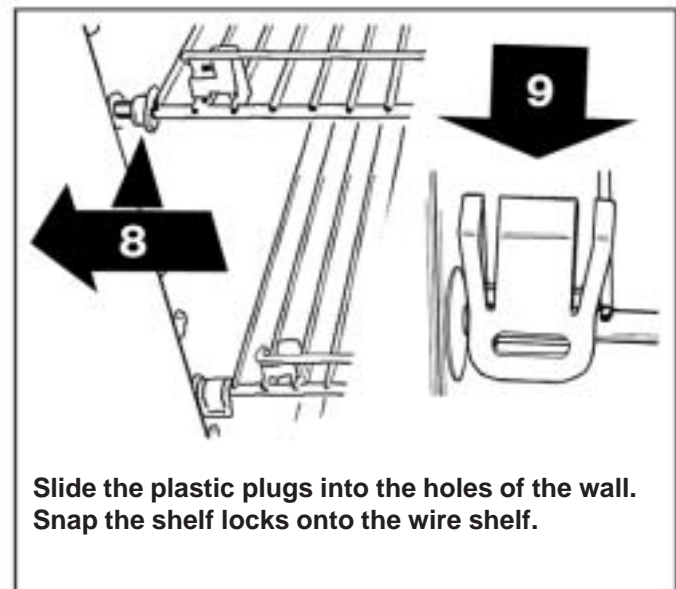
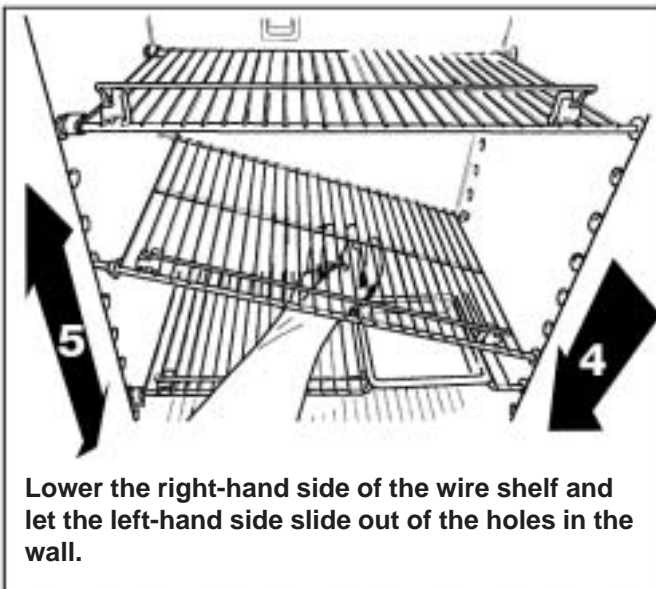
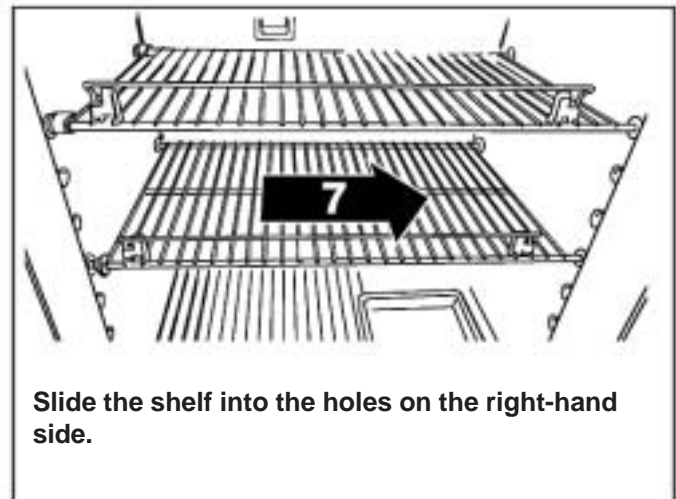
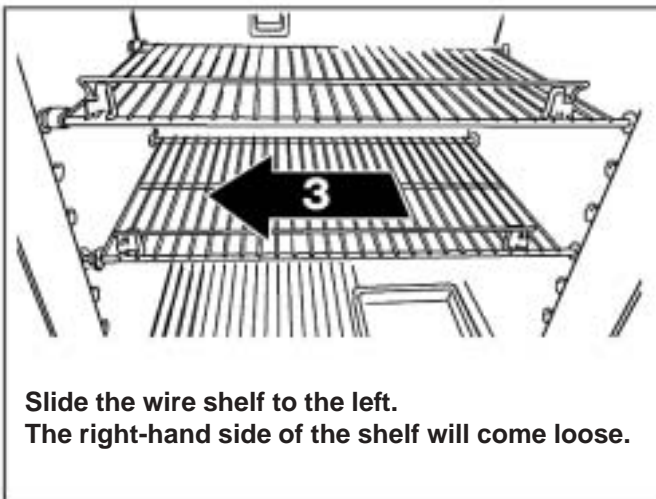
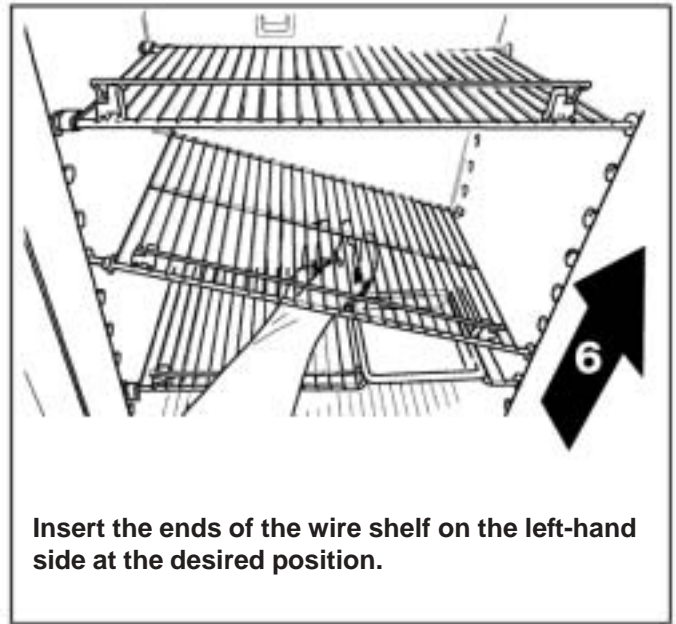
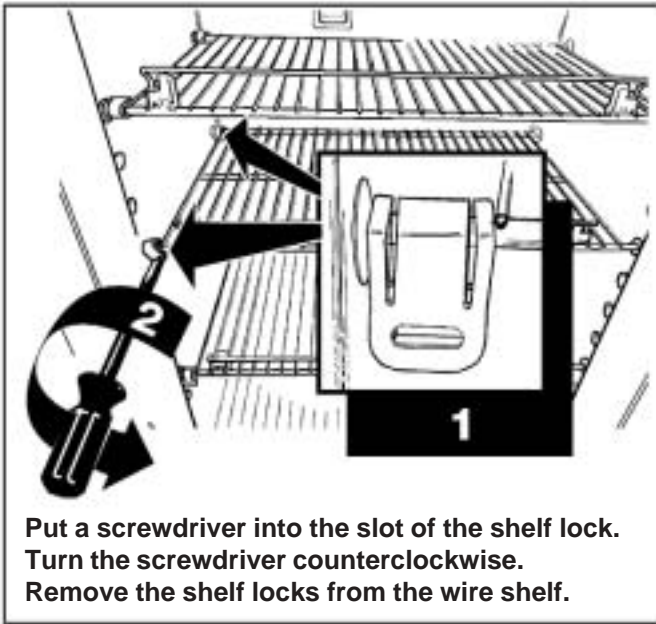

385 06 23

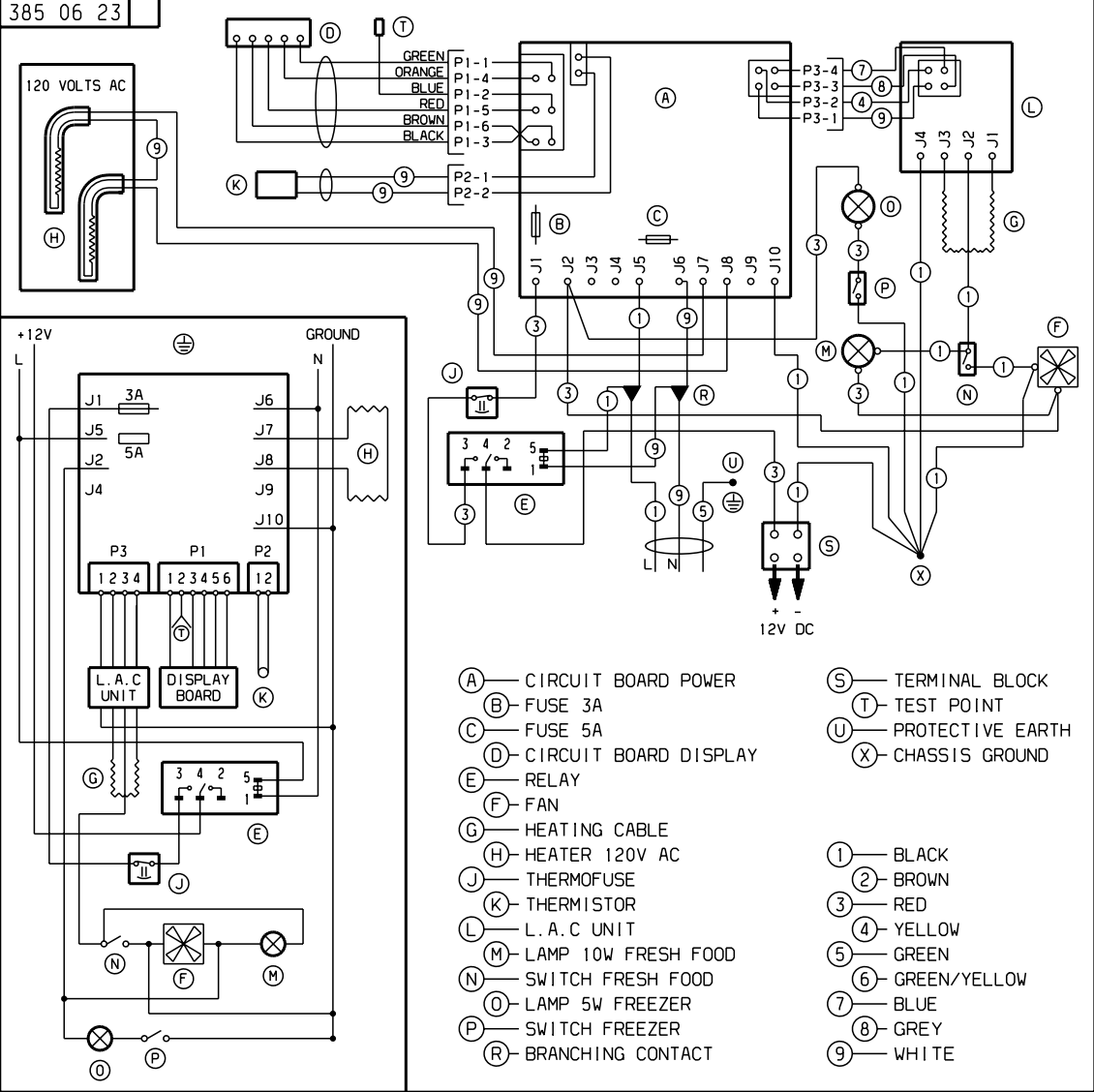

- (A) — CIRCUIT BOARD POWER
 - (B) — FUSE 3A
 - (C) — FUSE 5A
 - (D) — CIRCUIT BOARD DISPLAY
 - (E) — RELAY
 - (F) — FAN
 - (G) — HEATING CABLE
 - (H) — HEATER 120V AC
 - (J) — THERMOFUSE
 - (K) — THERMISTOR
 - (L) — L. A. C. UNIT
 - (M) — LAMP 10W FRESH FOOD
 - (N) — SWITCH FRESH FOOD
 - (O) — LAMP 5W FREEZER
 - (P) — SWITCH FREEZER
 - (R) — BRANCHING CONTACT
 - (S) — TERMINAL BLOCK
 - (T) — TEST POINT
 - (U) — PROTECTIVE EARTH
 - (X) — CHASSIS GROUND
-
- (1) — BLACK
 - (2) — BROWN
 - (3) — RED
 - (4) — YELLOW
 - (5) — GREEN
 - (6) — GREEN/YELLOW
 - (7) — BLUE
 - (8) — GREY
 - (9) — WHITE

