

DUO-THERM[®]

by Dometic

RECORD THIS INFORMATION FOR FUTURE REFERENCE
BEFORE INSTALLING THE UNIT:

Model Number _____
Serial Number _____
Date Purchased _____
Place of Purchase _____

MODEL 630015.301 Roof-Top Heat Pump

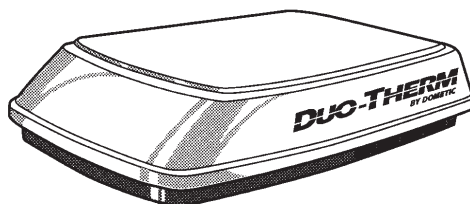

USA
SERVICE OFFICE
The Dometic Corp.
509 So. Poplar St.
LaGrange, IN 46761

CANADA
Dometic Dist.
866 Lings Dr.
Cambridge, Ontario
CANADA N3H 2N7

**THIS UNIT IS DESIGNED FOR OEM INSTALLATION
ALL INITIAL INSTALLATIONS MUST BE APPROVED BY THE SALES DEPT.**

WARNING

This unit must be serviced by an authorized serviceman. Modification of the appliance can be extremely hazardous and could lead to serious injury or death.

AVIS

Cet appareil doit être réparé seulement par un réparateur autorisé. Modification de l'appareil pourrait être extrêmement dangereuse, et pourrait causer mal ou mort.

INSTALLATION & OPERATING INSTRUCTIONS

MODEL 630015.301



**UNDERWRITERS
LABORATORIES
INC. ®**

LISTED
637G



CERTIFIED
LR 23565

1. GENERAL INFORMATION

A. The rooftop heat pump was designed to operate in a MILD GEOGRAPHICAL AREA for heating where the heat loss is minimum. The 630015.301 will operate down to an outside ambient temperature of 40 degrees. At 40 degrees, the outdoor thermostat will turn off the heat pump circuit and start up the coach's main furnace. As long as the temperature remains below 40 degrees, the main furnace will heat your home. As the outside temperature increases to 45 degrees, the outdoor thermostat switches back to the heat pump circuit.

The advantages of the 630015.301 Heat Pump Air Conditioner are:

- 1) User friendly- only one unit for both heating and cooling.
- 2) When used in mild climates where the outdoor temperature range is 40 degrees or higher, an L.P. furnace is not needed.
- 3) Heat pump heating uses the campsite electrical hookup; therefore, you save on trips to refill L.P. tanks.

NOTE: Geographical location usage should be determined before omitting a central furnace.

B. This air conditioner is designed for:

- 1) Installation on a recreational vehicle at the time the vehicle is manufactured.
- 2) Mounting on the roof of a recreational vehicle.
- 3) Connection to an air distribution system located in the ceiling/roof cavity of the recreational vehicle.
- 4) Roof construction with rafters/joists on minimum of 16 inch centers.
- 5) Minimum of 1.75 inches and maximum of 4.50 inches distance between roof to ceiling of recreational vehicle. Alternate installation methods will allow for roofs more than 4.50 inches thick.

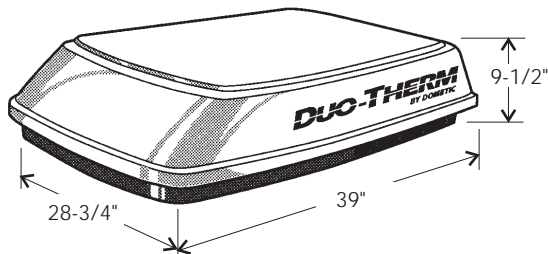

2. PRECAUTIONS

WARNING

IMPROPER INSTALLATION MAY DAMAGE EQUIPMENT, COULD ENDANGER LIFE, CAUSE SERIOUS INJURY AND/OR PROPERTY DAMAGE.

SPECIFICATIONS

MODEL NO.	630015.301
Nominal Capacity (BTU/HR)	Cooling = 13,500/Heating = 13,500
Electrical Rating	115 VAC, 60 Hz., 1 PH.
Compressor Rated Load Amps	12.4
Fan Motor Rated Load Amps	3.1
Compressor Locked Rotor Amps	60.0
Fan Motor Locked Rotor Amps	8.8
Power, Cooling (KW)	1.8
SCFM-High Speed Max./Min.	335/250
Total Static – Min./Max.	.10 / .65
Refrigerant (R22) oz.	23.0
Minimum Wire Size *	12 AWG Copper Up to 24 ft.
Circuit Protection	20 Amp Time Delay Fuse or HACR Circuit Breaker
Installed Weight (Pounds)	100
Minimum Generator	1 Unit 3.5 KW
Size **	2 Units 5.0 KW

* For distances over 24 ft. consult the National Electrical Code.
 ** The Dometic Corporation gives **GENERAL** guidelines for generator requirements. These guidelines come from experiences people have had in actual applications. When sizing the generator, the total power usage must be considered. Also keep in mind generators lose power at high altitudes and from lack of maintenance.

- A. Read installation and operating instructions carefully before starting your air conditioner installation.
- B. The Dometic Corporation will not be liable for any damages or injury incurred due to failure in following these instructions.
- C. Installation **must** comply with the National Electrical Code and any State or Local Codes or regulations.
- D. **DO NOT** add any devices or accessories to this air conditioner except those specifically authorized by Dometic.
- E. This equipment must be serviced by qualified personnel and some states require these people to be licensed.

3. CHOOSING PROPER LOCATION FOR THE AIR CONDITIONER

This air conditioner is specifically designed for installation on the roof of a recreational vehicle (RV). When determining your cooling requirements, the following should be considered:

1. Size of RV;
2. Window area (increases heat gain);
3. Amount of insulation in walls and roof of RV;
4. Geographical location where RV will be used;
5. Personal comfort level required.

From this information the **size** of air conditioner(s) and the **number** of air conditioners needed can be determined.

A. NORMAL LOCATION

The air conditioner is designed to fit over a roof opening 14" x 14".

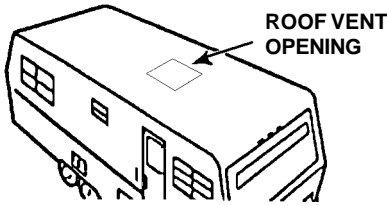

B. OTHER LOCATIONS

When no roof vent is available or another location is desired, the following is recommended:

For one unit installations: The air conditioner should be mounted slightly forward of center (front-to-back) and centered from side-to-side.

For two unit installations: Install one air conditioner 1/3 and one air conditioner 2/3's from the front of RV and centered from side-to-side.

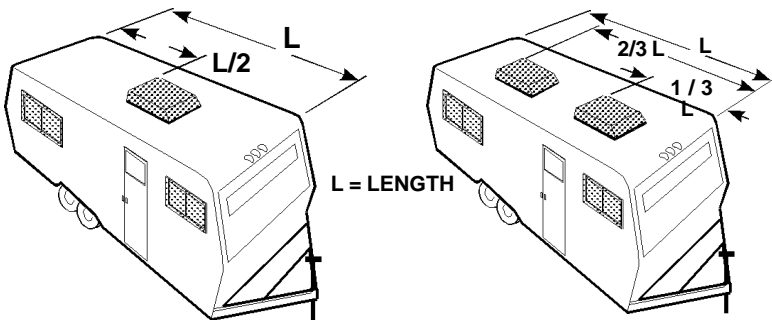

It is preferred that this air conditioner be installed in a relatively **flat and level** roof section measured with the RV parked on a level surface; however, up to 15 degree slant to either side, or front-to-back, is acceptable.

C. After the location has been selected:

1. Check for obstructions in the area where the air conditioner will be installed.

**AIR CONDITIONER DIMENSIONS
(On top of vehicle)**

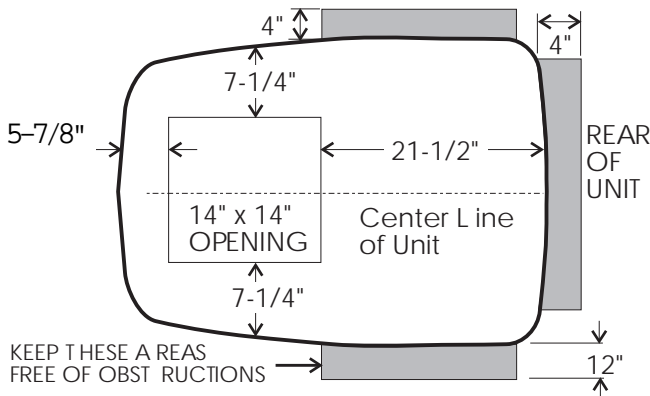

2. The roof must be designed to support 130 lbs. when the RV is in motion. Normally 200 lb. static load design will meet this requirement.

4. AIR DISTRIBUTION SYSTEM SIZING AND DESIGN

The Installer of this air conditioner system must design the air distribution system for his particular application. Several requirements for this system **MUST** be met for the air conditioner to operate properly. These requirements are as follows:

- A. Roof cavity thickness must be between 1.75" to 4.50". This distance is measured between roof and ceiling surface.
- B. The total **Cross-Sectional Discharge Area** of outlet ducts from the plenum area under the air conditioner must be a minimum of 21.0 sq. inches.

C. Duct sizing requirements are as follows:

	Min.	Max.
1. Duct Depth	1.50"	2.50"
2. Duct Width	7.00"	10.00"
3. Total Duct Length	12'	36'
4. Duct Length (short run)	1/3 Total Length	

D. Register requirements as follows:

	Min.	Max.
1. Distance from duct end	5"	8"
2. Distance from end of elbow	15"	—
3. Distance between registers	24"	—
4. Total number required	4	8
5. Number required per run	2	—
6. Free area per register	14 sq.in.	—

- E. The duct material must meet or exceed any agency or RVIA Standard that may be in existence at the time the RV is produced.

NOTE: IT IS THE RESPONSIBILITY OF THE INSTALLER OF THIS SYSTEM TO INSURE THE DUCTWORK WILL NOT COLLAPSE OR BEND DURING OR AFTER THE INSTALLATION.

- F. All discharge air ducts must be properly insulated to prevent condensation from forming on their surfaces or adjacent surfaces during operation of the air conditioner. This insulation must be R-7 minimum.

- G. Ducts and their joints must be sealed to prevent condensation from forming on adjacent surfaces during operation of the air conditioner.

NOTE: THE DOMETIC CORPORATION WILL NOT BE HELD LIABLE FOR ROOF STRUCTURAL OR CEILING DAMAGE DUE TO IMPROPERLY INSULATED OR SEALED DUCTWORK.

- H. Return air opening must have 40 sq. in. minimum free area including the filter.
- I. Return air to the air conditioner must be filtered to prevent dirt accumulation on the air conditioner cooling surface.
- J. Total system pressure must be between 0.40 to 1.10 in. W.C. This is to be determined with the air conditioner blower operating on high speed and return air filter and grill in place.

NOTE: IT IS THE RESPONSIBILITY OF THE INSTALLER OF THIS AIR CONDITIONER SYSTEM TO INSURE THE STRUCTURAL INTEGRITY OF THE RV ROOF.

- K. The thermostat must be located on an inside wall of the RV, 60 inches above the floor. The thermostat must not be located near a heat source.

5. AIR DISTRIBUTION SYSTEM INSTALLATION

The Dometic Corporation recommends the basic configuration shown below for installing this air conditioner system. We have found by testing that this configuration works best in most applications of this air conditioner system.

It is the responsibility of the Installer of this system to review each RV floor plan and determine the following:

- A. Duct size;
- B. Duct layout;
- C. Register size;
- D. Register locations;
- E. Thermostat location.

These items must be determined in conjunction with the air distribution system sizing and design requirements listed in Section 4 of this Manual.

ALTERNATE CONFIGURATIONS AND METHODS MAY BE USED WHICH STILL ALLOW THE AIR CONDITIONER TO OPERATE PROPERLY. HOWEVER, THESE ALTERNATE CONFIGURATIONS AND METHODS MUST BE APPROVED BY THE DOMETIC CORPORATION IN WRITING.

- A. **ROOF AND CEILING OPENING PREPARATION**
 1. A 14" x 14" opening must be cut through the roof and ceiling of the RV. This opening must be located between the roof reinforcing members.

WARNING

THERE MAY BE ELECTRICAL WIRING BETWEEN THE ROOF AND THE CEILING. DISCONNECT ALL POWER SUPPLIES AND THE POSITIVE (+) TERMINAL FROM THE SUPPLY BATTERY. FAILURE TO FOLLOW THIS INSTRUCTION MAY CREATE A SHOCK HAZARD.

2. Mark a 14" x 14" square on the roof and carefully cut the opening.
3. Using the roof opening as a guide, cut the matching hole in the ceiling.
4. The opening created must be framed to provide adequate support and prevent air from being drawn from the roof cavity. Lumber 3/4" or more in thickness must be used. Remember to provide an entrance hole for power supply wiring and thermostat cable.

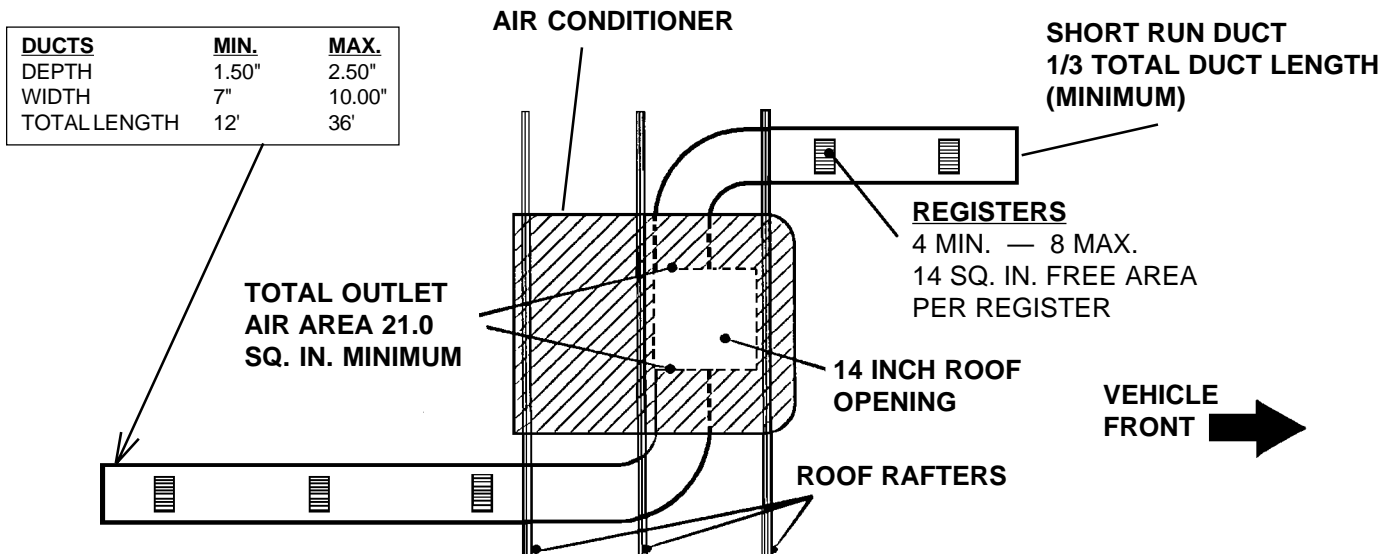

5. The 14" opening is part of the return air system of the air conditioner and must be finished in accordance with NFPA Standard 501C Section 2.7.
6. Route a copper 12 AWG with ground supply line from fuse or circuit breaker box to the roof opening.
 - a. This supply line must be located in the front portion of the 14" opening.
 - b. The power supply **MUST** be on a separate 20 amp time delay fuse or HACR circuit breaker.
 - c. Make sure at least 15" of supply wire extends into the roof opening. This insures easy connection at the air conditioner junction box.
 - d. Wiring must comply with all National, State and Local Wiring Codes.
 - e. Use a steel sleeve and a grommet or equivalent methods to protect the wire where it passes into the opening.

B. AIR DISTRIBUTION DUCT INSTALLATION

Install the air distribution ducts in the RV roof cavity. The Distribution system must meet:

1. The RV's requirements;
2. System requirements listed in Section 4 of this Manual.

Terminate the start of the duct at the back edge of the 14" opening previously cut.

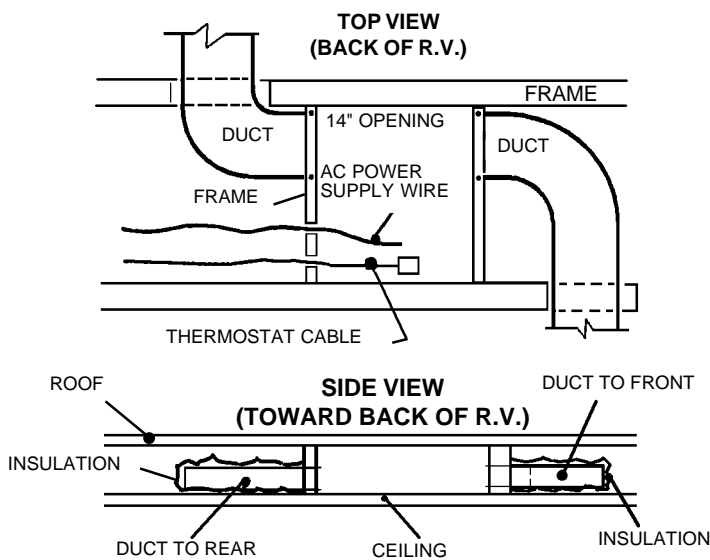

6. THERMOSTAT AND CABLE INSTALLATION

A. LOCATION

The proper location of the thermostat is very important to insure that it will provide a comfortable RV temperature. Observe the following general rules when selecting a location.

1. Locate the thermostat about 5 feet above the floor.
2. Install thermostat on a partition, not on an outside wall;
3. **NEVER** expose it to direct heat from lamps, sun or other heat producing items;
4. Avoid locations close to doors that lead outside, windows or adjoining outside walls;
5. Avoid locations close to supply registers and the air from them;
6. Never locate thermostat in a room that is warmer or cooler than the rest of the coach — such as the kitchen;
7. The major living area is normally a good location.

B. CABLE INSTALLATION

The cable must be routed from the roof opening to the Thermostat.

1. Choose the shortest, most direct route from the 14" opening to the Thermostat location selected.
 2. Three standard cable lengths are available:

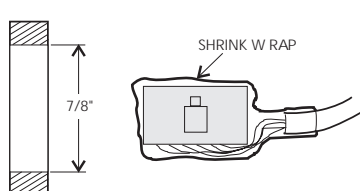
a. 15 feet	Part No. 3101632.010
b. 25 feet	Part No. 3101632.028
c. 30 feet	Part No. 3101632.036
 3. The Thermostat end of the cable is covered with heat shrink tubing. This allows cable routing through a 7/8" diameter hole without damage to the plug. NOTE: The tubing must be carefully removed before connection to the Thermostat.
- 
4. Consider where screws, nails or staples might contact the cable.
 5. Leave 6" of cable extending through the wall for connection to the Thermostat.
 6. Enough cable must extend into the 14" opening to allow connection to the low voltage cable from the upper unit.

C. THERMOSTAT WIRING

Thermostat wiring for Dometic Bimetal thermostat:

Route the (10) conductor cable from the 14"x14" opening to the thermostat location. Leave enough cable within the 14"x14" opening to connect to the low voltage cable. At the thermostat location, leave about six (6") inches of cable extending through the wall. Plug the thermostat cable into the thermostat connector cable.

When an auxiliary furnace is used with the heat pump, a two conductor cable must be routed from the furnace to the thermostat location. Connect one wire from the furnace to the violet wires with a wire nut. Connect the other wire from the furnace to the green wire in the thermostat cable and secure with a wire nut. Tuck the excess wire back into the wall and fill opening with insulation to prevent drafts that could affect the thermostat operation. Secure the thermostat to the wall using the two screws.

D. THERMOSTAT OPERATION

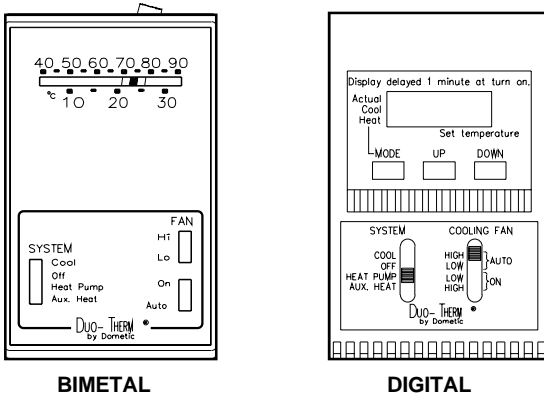

Cooling:

- 1) Set the SYSTEM SWITCH to COOL.
- 2) Set the temperature LEVER to your comfort level.
3. Set the FAN switch to:
 - a) AUTO: The fan cycles off and on with the compressor.
 - b) ON: The fan will run continuously. The compressor will turn off when the room temperature is cool enough to satisfy the thermostat setting.

Heating:

- 1) Set the system switch to HEAT:
- 2) Set the temperature LEVER to your comfort level.
- 3) Set the FAN switch to:
 - a) AUTO: The fan will cycle off and on with the compressor.
 - b) ON: The fan will run continuously. The compressor will cycle off and on with thermostat demand.

Auxiliary Heat:

- 1) Set the system switch to AUX.HEAT.
- 2) Set the fan switch to AUTO.

NOTE: The auxiliary heat position is only used if:

- 1) You have a factory installed furnace operating from the heat pump system thermostat.

- 2) The outside temperature is above 40 degrees and you wish to operate your furnace.
3. For quick interior warm up.
4. There is no 115 volt AC power available to operate your heat pump and you must operate the furnace for your comfort.

Fan:

To circulate air without heating or cooling:

- 1) Set the SYSTEM SWITCH to OFF.
- 2) Set the FAN SWITCH to ON.

Hi/Low:

HIGH: Fan speed position
 LOW: Fan speed position

E. THERMOSTAT WIRING

Thermostat wiring for DIGITAL thermostat: Route the (10) conductor cable from the 14"x14" opening to the thermostat location. Route a two conductor cable from the coach's 12 volt DC power source to the thermostat location. Connect 12 volt **positive** lead to the green wire on the thermostat cable.

Connect the 12 DC volt **negative** lead to the brown lead. Secure both connections using wire nuts.

At the thermostat location, leave about six (6") inches of cable extending through the wall. Plug the thermostat cable into the thermostat connector cable.

When an auxiliary furnace is used with the heat pump, a single wire conductor must be routed from the furnace to the thermostat location. Connect this wire from the furnace to the violet pigtail at the thermostat and secure with wire nut. Tuck the excess wire back into the wall and fill opening with insulation to prevent drafts that could affect the thermostat operation. Using the two screws provided, secure the thermostat to the wall

NOTE: The furnace has two wires for thermostat connections. One wire should be marked 12V DC or (+) and the other wire may be unmarked, or labeled "thermostat". The wire marked 12V DC or (+) should be capped and not used with the heat pump setup. The wire marked "thermostat" or the unmarked wire is the wire to connect to the violet thermostat pigtail. See Wiring Diagram on Page 13.

F. DIGITAL THERMOSTAT OPERATION

Your air conditioner is operated from the control panel of the electronic wall thermostat. When the furnace is connected to this thermostat, it will operate from the same control panel.

Identification and operational descriptions for all control panel switches and display are listed below:

- 1) **Liquid Crystal Display:** This display will be illuminated any time the system is in operation.

The display shows the operator both the mode of the display (indicated by the arrow at the left side of the display), and the temperature for that mode.

There are three display modes: ACTUAL, COOL and HEAT.

The operator may choose the mode he desires to view by depressing the "MODE" switch. Each time the MODE switch is depressed, the display advances to the next mode. If the display is left in either COOL or HEAT, the thermostat will automatically return the display to ACTUAL in approximately three minutes.

A description of the three modes is:

ACTUAL: When in actual mode, the display is indicating current room temperature.

COOL SET: When in COOL mode, the display is indicating the current cooling set-point temperature. At this time the cooling system set-point temperature may be adjusted up or down to meet the individual's comfort level. See "Adjusting Set-point" for further instructions.

HEAT SET: When in the HEAT mode, the display is indicating the current heating system set-point temperature. At this time, the heating system set-point temperature may be adjusted up or down to meet the operator's comfort level. See "Adjusting Set-Point" for further instructions.

All three display modes can be accessed without affecting the operation of the system. The system operation will remain normal unless a change is made to the set-point to force a change in the system operation.

2) **System Switch:** The system switch has four positions to control the operation of the heating and cooling systems. They are as follows:

COOL: When in the COOL position, the compressor will cycle from the cooling system set-point. Blower operation will be controlled by the position of the Cooling Fan Switch.

HEAT: When in the heat position, the heating system will cycle from the heating system set-point. The heating blower will operate per the heating system manufacturer specifications.

OFF: When in the OFF position, no thermostat or system operation will occur. The liquid crystal will indicate room temperature until backup power is depleted (approximately 2 minutes).

AUXILIARY HEAT:

- 1) Set the system switch to AUX. HEAT.
- 2) Set the FAN switch to AUTO.

NOTE: The AUXILIARY HEAT position is only used if:

- 1) You have a factory installed furnace operating from the heat pump system thermostat.
- 2) The outside temperature is above 40 degrees and you wish to operate your furnace.
- 3) For quick interior warm-ups.
- 4) There is no 115 volt AC power available to operate your heat pump and you must operate the furnace for your comfort.

FAN SWITCH: The Fan Switch has four positions from which to control the operation of the heat pump blower.

The fan switch controls operation of the blower only after the system switch is placed into the COOL or HEAT PUMP position.

HIGH AUTO: When in the high auto position, the heat pump blower operates at high speed and cycles off and on with the compressor.

LOW AUTO: When in low auto position, the heat pump blower operates at low speed and cycles off and on with the compressor.

HIGH and LOW ON: When in the high or low position, the heat pump blower operates continuously. The compressor cycles off and on as needed.

MOMENTARY SWITCHES: There are three momentary switches. Momentary switches are activated by depressing the center of the switch. A description of these three switches follows:

MODE: Depressing this switch advances the display mode from ACTUAL to COOL, HEAT and back to ACTUAL. When using this switch, you are indicating your desire to check or adjust the set-point temperatures for cooling or heating. The cool setting determines the temperature at which the air conditioner will start to operate. The heat setting determines the temperature at which the heating system will start to operate.

UP: Depressing this switch increases the temperature set-point.

DOWN: Depressing this switch decreases the temperature set-point.

To adjust the set-point for heating or cooling, press the MODE button until the arrow on the display indicates the desired set-point you wish to change: COOL or HEAT. The display will indicate the current set-point of the thermostat. Press UP or DOWN to change the set-point. Once the new desired set-point is displayed, press the MODE button until the arrow is pointing to ACTUAL. If the thermostat is left in the COOL or the HEAT mode the display will return to ACTUAL in about three minutes. After the display returns to ACTUAL, it takes 15 to 30 seconds for the thermostat to recognize the changes made to the set-point.

7. PLACING AIR CONDITIONER ON THE ROOF

- A. Remove and discard the carton. The unit mounting bolts and literature are in separate plastic bag. Be sure to place this information in the RV.
- B. Place the air conditioner on the roof.

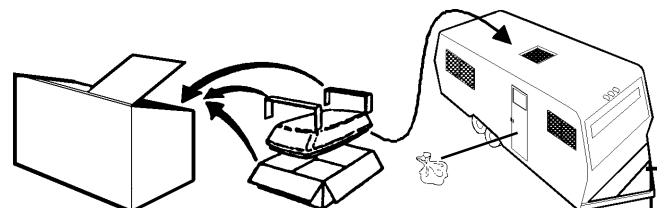

! CAUTION

USE CARE IN LIFTING. THIS UNIT WEIGHS APPROXIMATELY ONE HUNDRED (100) POUNDS.

- C. Lift and place the unit over the prepared opening using the gasket on unit as a guide. The blunt end goes toward the rear of the RV.

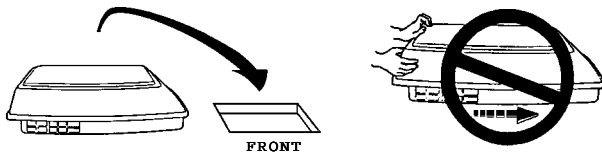

! CAUTION

DO NOT SLIDE THE UNIT. THIS MAY DAMAGE THE NEOPRENE GASKET ATTACHED TO THE BOTTOM AND CREATE A LEAKY INSTALLATION.

This completes the outside work. Minor adjustments can be done from the inside of the RV if required.

8 CONNECTION OF POWER SUPPLY

A. MOUNTING AIR CONDITIONER JUNCTION BOX

1. Position the Air Conditioner junction box in a convenient location in the front portion of the 14" opening.
2. With two (2) # 8 x 1/2" screws provided, secure to wall of opening.

B. CONNECTION OF 115 VOLT POWER SUPPLY

! WARNING

Disconnect **ALL** power before wire leads are connected.



1. Select the best location for entrance of supply wire into the junction box and remove appropriate knockout slug from box.
2. Install the strain relief connector into the junction box. Route the power supply line through this connector.

3. Connect the white to white; black to black; and green to green or bare copper wire using the appropriate sized twist wire connectors. Tape the twist wire connectors to the supply wiring to assure they do not vibrate off.

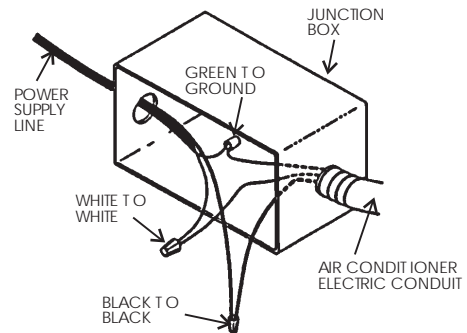

4. Tighten screws on strain relief connector being careful not to pinch and cut into the insulation on power supply leads.
5. Push excess wires into junction box and install junction box cover onto the junction box.

9. INSTALLATION OF AIR CONDITIONER

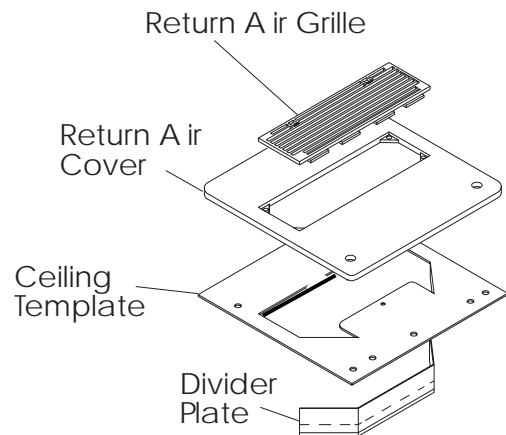

A. INSTALLATION OF CEILING TEMPLATE

- 1) Check gasket alignment of the Air Conditioner over roof opening and adjust if necessary. Unit may be moved from below by slightly lifting and sliding.
- 2) Remove Return Air Cover and Ceiling Template from the return air cover kit carton.
- 3) Remove Parts Package and Thermostat from its carton.
- 4) Locate 1/4" unit mounting bolts in the parts package.
- 5) Take the ceiling template and hold up to the 14" opening. Be sure the solid end faces the rear of the RV.

- Start each mounting bolt through the ceiling template and up into the unit base pan by hand.

EVENLY TIGHTEN MOUNTING BOLTS TO A TORQUE OF 40 TO 50 INCH POUNDS

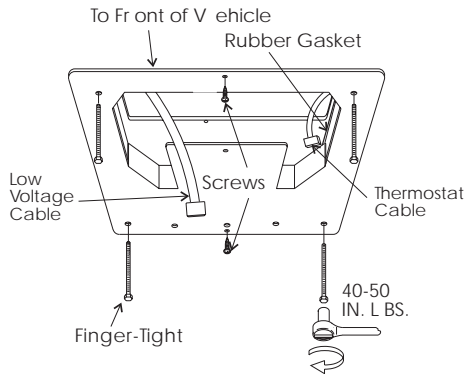

This will compress the roof gasket to approximately 1/2". The bolts are self locking so over tightening is not necessary.

- Install wood screw in each end of ceiling template. This insures a tight fit of return air cover to ceiling.

B. INSTALLATION OF DIVIDER PLATE

- Measure the ceiling to roof thickness:
 - If distance is 2.00" - 3.75", remove perforated tab from Divider Plate.
 - If distance is 3.75" - 5.50", remove no tabs.
- Remove the backing paper from double sided tape located on Ceiling Template.

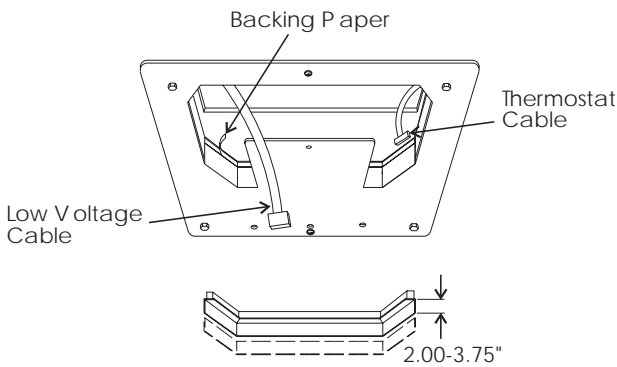

- Place Divider Plate up to bottom of Air Conditioner base pan firmly. The foam tape on the divider plate must seal to bottom of base pan.

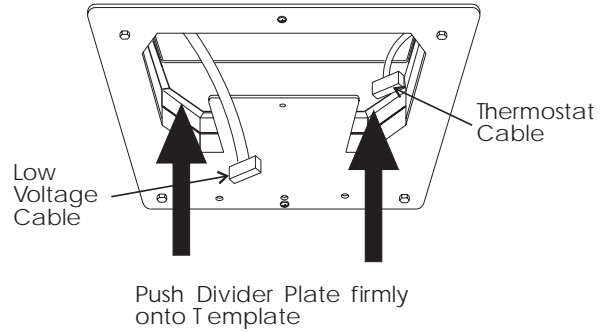

Note: The adhesive on double sided tape is extremely sticky. Divider Plate must be properly positioned before pressing in place.

- With slight pressure then push divider plate against exposed double sided tape on ceiling template.
- Locate 1/8" x 7" x 18" self-adhesive insulation supplied with the Return Air Kit.
- Remove the backing paper from the insulation and carefully stick onto the ceiling template divider panel.

Note: The adhesive on insulation is extremely sticky. Be sure part is located where desired before pressing into place. We recommend pulling off part of backing paper, locating part and then remove backing paper as insulation is pressed into place.

- Excess width is intended to seal the divider plate to the sides of the 14" opening, This is to prevent cold discharge air from circulating into the Air Conditioner return air opening.
- If the insulation is too high, stick the excess height of insulation to the Air Conditioner base pan. **Note: Do not cover up unit rating plate.**
- Connect low voltage cable to thermostat cable.

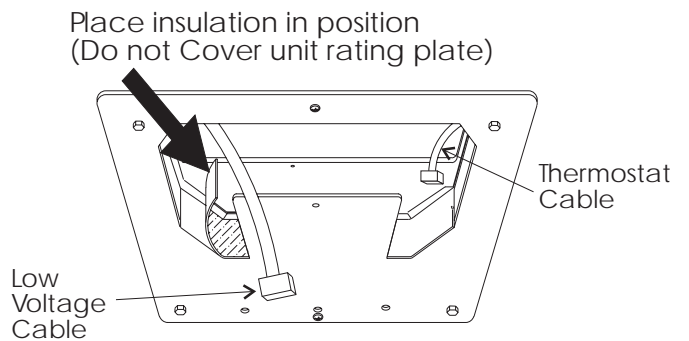

C. INSTALLATION OF RETURN AIR COVER

- 1) Remove Return Air Grille from the Return Air Cover.
- 2) Place the Return Air Cover up to Ceiling Template.
- 3) Install Cover to Template with #8 x 3/8" blunt point phillips head screws provided (6 required).
- 4) Reinstall Return Air Grille into Return Air cover.
- 5) Install two (2) hole plugs into screw holes in back of return air grille. Align tabs with mating notches and snap into place.

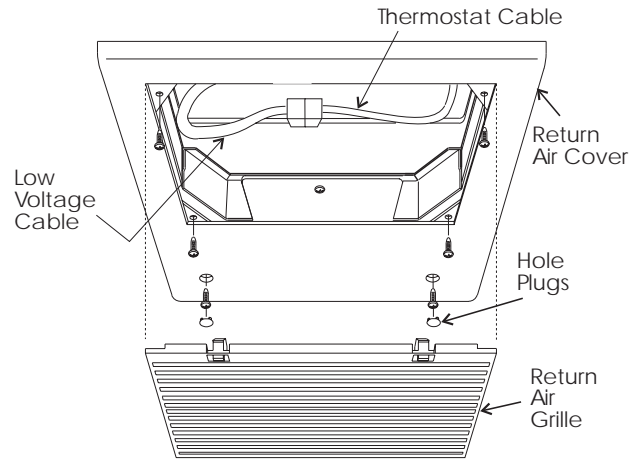

ROOF MOUNT ASSEMBLY

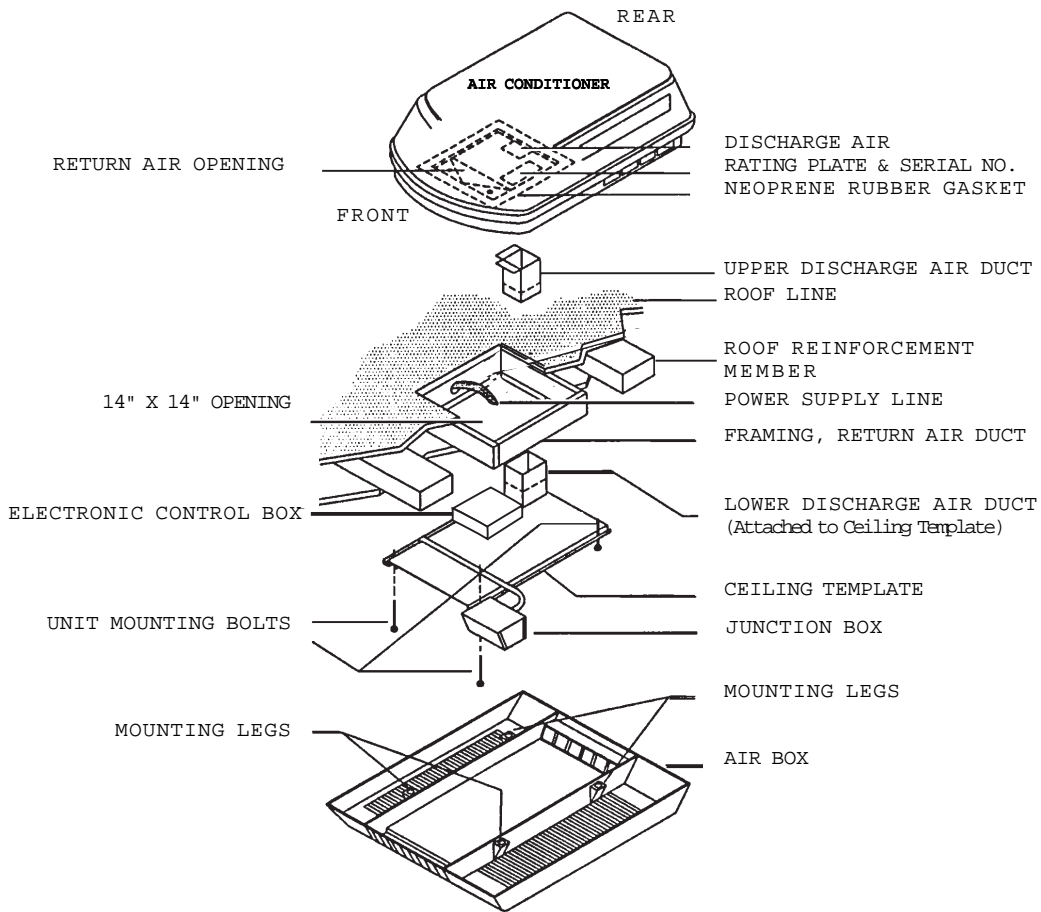

10. DISCHARGE DUCT & CEILING TEMPLATE INSTALLATION

Remove the air box and mounting hardware from their carton. The upper duct is shipped inside the lower duct which is part of the ceiling template. The mounting hardware is in a plastic bag.

NOTE: Refer to Section 8, Page 8, for junction box location and power connection.

Refer to Section 9, Page 10, for low voltage cable to thermostat cable connection.

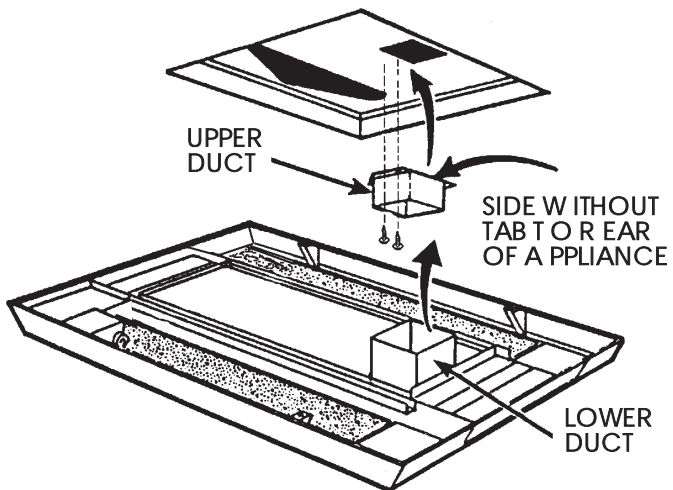

1. Remove the upper duct from the ceiling template and locate it over the blower discharge. NOTE: The edge without the flange installs toward the **rear** of the RV.
2. Use two of the sharp pointed sheet metal screws to hold the duct to the base pan. The holes are prepunched in the pan for each of location.
3. Check gasket alignment over roof opening and adjust if necessary. Unit may be moved from below by lifting and sliding.
4. Reach up into the return air opening and pull the conduit power cable down for later connection.

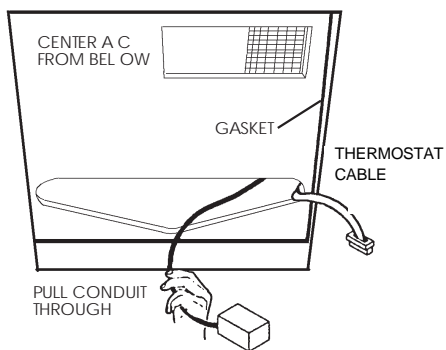

5. Measure the ceiling thickness:
 - a. If the distance is 2" to 3" remove the perforated tabs from the bottom duct only.
 - b. If the distance is 3" to 4-1/4" install the ducts as received.
 - c. If the distance is 4-1/4" to 6" (maximum thickness), optional duct and bolt kits are available:

Duct (Part No. 318556)
Bolts (Part No. 318557)

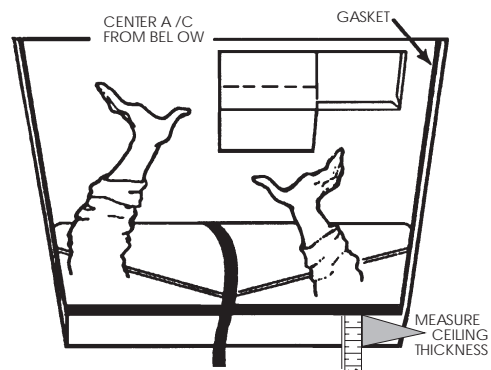

6. Take the ceiling template and slide the lower duct over the upper duct.
7. Hold the ceiling template with one hand and with the other, install the three 1/4" mounting bolts through the template and into the base pan. (Refer to illustration on Page 8.
 - a. Finger-tighten the (3) bolts and check alignment. There should be an equal opening on each side and the rear flange must be tight against the roof opening.
 - b. **EVENLY** tighten the bolts to a torque of 40 to 50 inch pounds. This will compress the roof gasket to approximately 1/2".

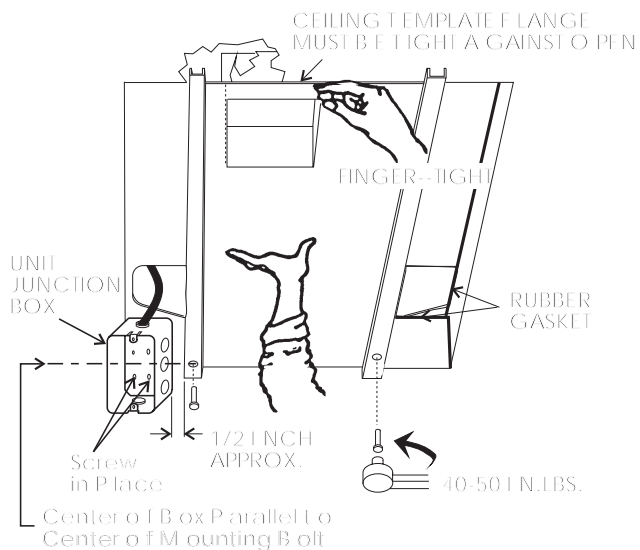

8. Take the ceiling template and slide the lower duct over the upper duct.
9. Hold the ceiling template with one hand and with the other, install the three 1/4" mounting bolts through the template and into the base pan. (Refer to illustration on Page 8.
 - a. Finger-tighten the (3) bolts and check alignment. There should be an equal opening on each side and the rear flange must be tight against the roof opening.
 - b. **EVENLY** tighten the bolts to a torque of 40 to 50 inch pounds. This will compress the roof gasket to approximately 1/2".

! CAUTION

If bolts are left loose there may not be an adequate roof seal. If bolts are over-tightened, damage may occur to the air conditioner base or ceiling template.

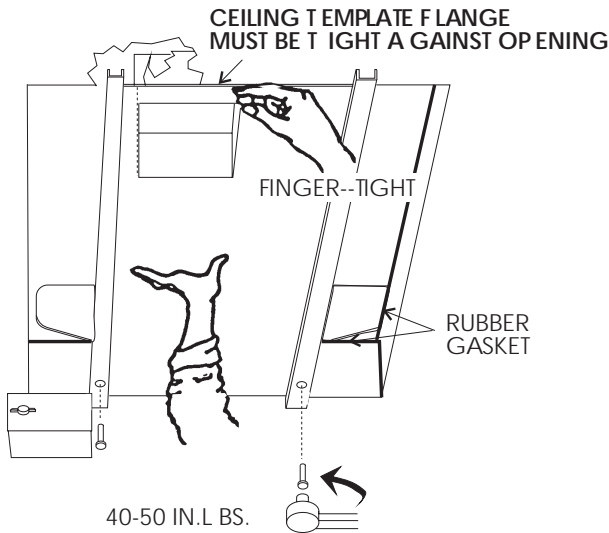

F. CONNECTION OF POWER SUPPLY

! WARNING

Disconnect ALL power before wire leads are connected.

1. Route supply line into junction box on ceiling template.
2. Connect white to white; black to black; and green to green or bare copper wire using appropriate sized twist connectors.
3. Tape the connectors to the wire with electrician's tape.
4. Push the wires into the box and tighten the strain relief.
5. Install the cover (part of the mounting hardware) with the one blunt point screw provided.

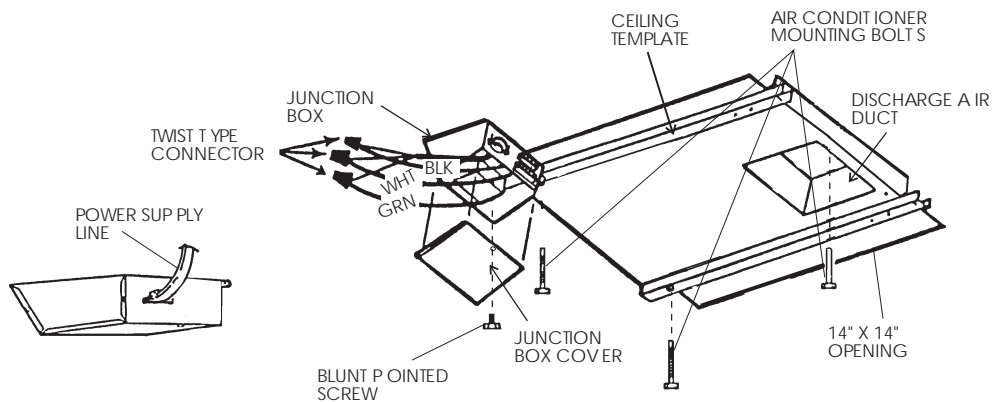

WIRING DIAGRAM

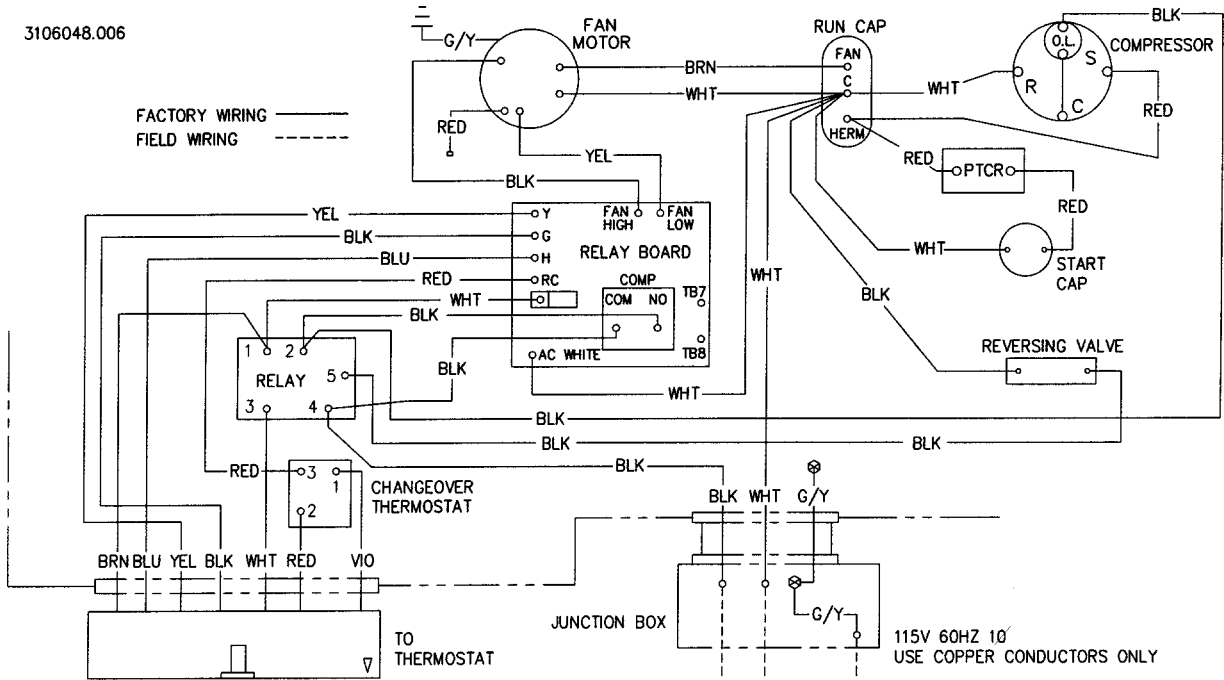

FURNACE TO THERMOSTAT CONNECTION

