

**Duo-THERM**<sup>®</sup>  
by Dometic

RECORD THIS INFORMATION FOR FUTURE REFERENCE  
BEFORE INSTALLING THE UNIT:

Model Number \_\_\_\_\_  
Serial Number \_\_\_\_\_  
Date Purchased \_\_\_\_\_  
Place of Purchase \_\_\_\_\_

# MODEL 59126.501 Roof-Top Heat Pump

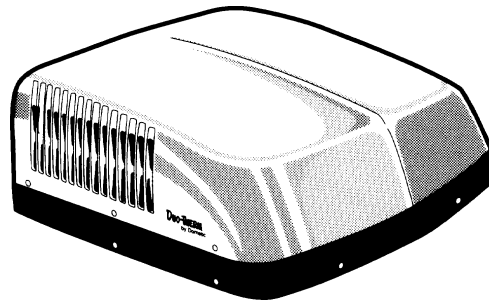

**USA**  
SERVICE OFFICE  
The Dometic Corp.  
509 So. Poplar St.  
LaGrange, IN 46761

**CANADA**  
Dometic Dist.  
866 Langs Dr.  
Cambridge, Ontario  
CANADA N3H 2N7

**THIS UNIT IS DESIGNED FOR OEM INSTALLATION  
ALL INITIAL INSTALLATIONS MUST BE APPROVED BY THE SALES DEPT.**

## WARNING

This unit must be serviced by an authorized serviceman. Modification of the appliance can be extremely hazardous and could lead to serious injury or death.

## AVIS

Cet appareil doit être réparé seulement par un réparateur autorisé. Modification de l'appareil pourrait être extrêmement dangereuse, et pourrait causer mal ou mort.

# INSTALLATION & OPERATING INSTRUCTIONS

# MODEL 59126.501



**UNDERWRITERS  
LABORATORIES  
INC.** <sup>®</sup>

LISTED  
637G



CERTIFIED  
LR 23565

# 1. SPECIFICATIONS

MODEL NO.	59126.501	
Nominal Capacity (BTU/HR)	Cooling = 15,000/Heating = 14,000	
Electrical Rating	115 VAC, 60 Hz., 1 PH.	
Compressor Rated Load Amps	12.9	
Fan Motor Rated Load Amps	4.0	
Compressor Locked Rotor Amps	71.0	
Fan Motor Locked Rotor Amps	12.8	
Power, Cooling (KW)	1.8	
SCFM-High Speed Max./Min.	450/300	
Total Static – Min./Max.	.40/1.10" W.C.	
Refrigerant (R22) oz.	34.5	
Minimum Wire Size *	12 AWG Copper Up to 24 ft.	
Circuit Protection	20 Amp Time Delay Fuse or HACR Circuit Breaker	
Installed Weight (Pounds)	110	
Minimum Generator	1 Unit	3.5 KW
Size **	2 Units	5.0 KW

- \* For lengths over 24 ft., consult the National Electrical Code.
- \*\* The Dometic Corp. gives **general** guidelines for generator requirements. These guidelines come from experiences people have had in actual applications. When sizing the generator, the **total** power usage of your recreational vehicle must be considered. Also keep in mind generators lose power at high altitudes and from lack of maintenance.

# 2. PRECAUTIONS

## WARNING

**IMPROPER INSTALLATION MAY DAMAGE EQUIPMENT, COULD ENDANGER LIFE, CAUSE SERIOUS INJURY AND/OR PROPERTY DAMAGE.**

- A. Read installation and operating instructions carefully before attempting to start your air conditioner.
- B. The Dometic Corporation will not be liable for any damages or injury incurred due to failure in following these instructions.
- C. Installation **must** comply with the National Electrical Code and any State or Local Codes or regulations.
- D. **DO NOT** add any devices or accessories to this air conditioner except those specifically authorized by Dometic.
- E. This equipment must be serviced by qualified personnel and some states require these people to be licensed.

# 3. OPERATING INSTRUCTIONS

## A. CONTROLS:

- 1. The Selector Switch has eight positions including "OFF". This controls fan speed, heating mode, and cooling modes.
- 2. The Thermostat controls the temperature range from 65° F on the coldest side to 90° F on the warmest side. In the cooling/heating mode, the compressor ON/OFF is controlled by the thermostat setting.

## B. COOLING OPERATION:

- 1. Set the thermostat at the desired temperature level.
- 2. Select the fan speed that best satisfies your needs:
  - a. **HIGH COOL:** Selected when maximum cooling and dehumidification required.
  - b. **LOW COOL:** Selected when room at desired comfort level and needs to be maintained. Normally this speed used for night time operation.

**NOTE:** The blower runs continuously to circulate air and maintain an even temperature. The compressor will come on when cooling is required to maintain the selected temperature level.

## WARNING

**AFTER SHUTTING THE AIR CONDITIONER DOWN WITH EITHER SELECTOR SWITCH OR THERMOSTAT, WAIT AT LEAST TWO (2) MINUTES BEFORE RESTARTING. THIS ALLOWS THE REFRIGERANT PRESSURE TO EQUALIZE AND COMPRESSOR TO RESTART EASILY.**

## C. FAN OPERATION:

This will circulate the air in your RV without cooling or heating. There are two positions: HIGH FAN or LOW FAN to select from, depending upon personal choice.

#### D. HEATING OPERATION:

NOTE: This heat pump will not replace a furnace for heating your RV in cold weather. The intent is to remove the chill on cool days or mornings.

1. Turn the selector switch to "HEAT PUMP".
2. The Fan and Compressor will come on and begin heating.
3. When desired temperature level in the RV is reached, the blower will run continuously to circulate air and maintain an even temperature. The compressor will cycle as required to maintain selected temperature.

E. "OFF" POSITION: This is to turn Unit off.

### 4. MAINTENANCE

#### A. AIR FILTER:

Periodically remove the return air filter located above the removable panel in the air box. Wash the filter with soap and warm water, let dry and the reinstall.

NOTE: Never run the air conditioner without return air filter in place. This may plug the unit evaporator coil with dirt and may substantially affect the performance of the unit.

#### B. AIR BOX HOUSING:

Clean air box housing and control panel with a soft cloth dampened with a mild detergent. Never use furniture polish or scouring powders.

#### C. FAN MOTOR:

Factory lubricated and requires no service under normal use.

#### D. FROST FORMATION ON COOLING COIL:

Under certain conditions, frost may form on the evaporator coil. If this should occur, inspect the filter and clean if dirty. Make sure air louvers are not obstructed. Air conditioners have a greater tendency to frost when the outside temperature is relatively low. This may be prevented by adjusting the thermostat control knob to a warmer setting (counterclockwise). Should frosting continue, operate on LOW or HIGH FAN setting until the cooling coil is free of frost.

### 5. GENERAL INFORMATION

The roof-top heat pump was designed to operate in a **MILD GEOGRAPHICAL AREA** for heating where the heat loss is minimal. The 59126.501 heat pump was designed to operate down to an outside ambient temperature of 40 degrees. At 40 degrees, the outdoor thermostat will turn off the heat pump circuit and start up the coach's main furnace. As long as the temperature remains below 40 degrees, the main furnace will heat your home. As the outside temperature increases to 45 degrees, the outdoor thermostat switches back to the heat pump circuit.

The advantages of the 59126 heat pump are:

1. User friendly; only one unit for both heating and cooling;
2. Heat pump heating uses campsite electrical hookup and saves on trips to refill L.P. tanks;
3. When used in mild climates where the outdoor temperature range is 40 degrees or higher, an L.P. furnace is not needed.

**NOTE: Geographical location usage should be determined before omitting a central furnace.**

The ability of the air conditioner to maintain the desired inside temperature depends on the heat gain of the RV. Some preventative measures taken by the occupants of the RV can reduce the heat gain and improve the performance of the air conditioner. During extremely high outdoor temperatures, the heat gain of the vehicle may be reduced by:

- a. Parking the RV in a shaded area
- b. Using window shades (blinds and/or curtains)
- c. Keeping windows and doors shut or minimizing usage
- d. Avoiding the use of heat producing appliances

Starting the air conditioner early in the morning and giving it a "head start" on the expected high outdoor ambient will greatly improve its ability to maintain the desired indoor temperature.

### NOTE

The manufacturer of this air conditioner will not be responsible for damage caused by condensed moisture on ceilings or other surfaces. Air contains moisture and this moisture tends to condense on cold surfaces. When air enters the RV, condensed moisture may appear on the ceiling, windows, metal parts, etc. The air conditioner removes this moisture from the air during normal operation. Keeping doors and windows closed when this air conditioner is in operation will minimize condensed moisture on cold surfaces.

### 6. SERVICE - Unit Does Not Operate

If your unit fails to operate or operated improperly, check the following before calling your service center.

- A. If RV connected to motor generator, check to be sure motor generator is running and producing power.
- B. If RV connected to power supply by a land line, check to be sure line is sized properly to run air conditioner load and it is plugged into power supply.
- C. Check your fuse or circuit breaker to see if it is open.
- D. After the above checks, call your local service center for further help. This unit must serviced by qualified service personnel only.

When calling for service, always give the air conditioner Model Number and Serial Number. This information can be found on unit rating plate located on the base pan near the return air opening. Return air grille must be removed from air box to view.

## 7. INSTALLATION INSTRUCTIONS

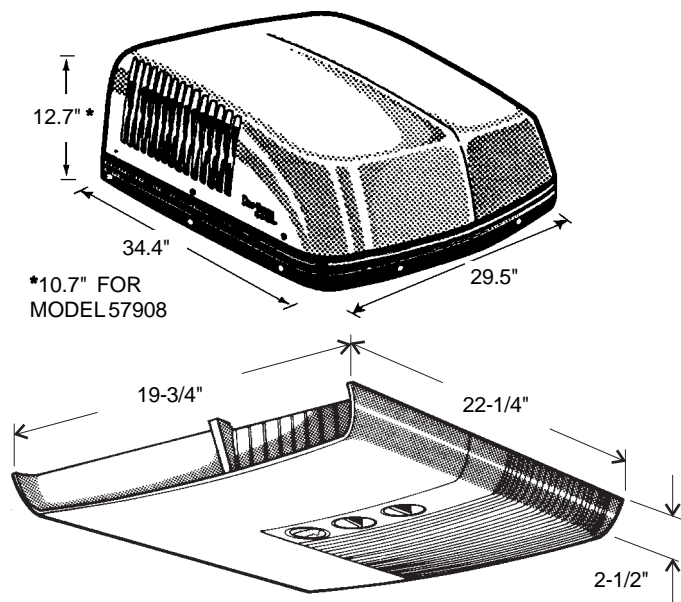

### A. PRECAUTIONS

#### WARNING

**IMPROPER INSTALLATION MAY DAMAGE EQUIPMENT, COULD ENDANGER LIFE, CAUSE SERIOUS INJURY AND/OR PROPERTY DAMAGE.**

1. Read Installation and operating instructions carefully before starting your air conditioner installation.
2. The Dometic Corporation will not be liable for any damages or injury incurred due to failure in following these instructions.
3. Installation must comply with the National Electrical Code and any State or Local Codes or regulations.
4. DO NOT add any devices or accessories to this air conditioner except those specifically authorized by Dometic.
5. This equipment must be serviced by qualified personnel and some states require these people to be licensed.

### B. CHOOSING LOCATION FOR THE AIR CONDITIONER

This air conditioner is specifically designed for installation on the roof of a recreational vehicle (RV).

#### 1. NORMAL LOCATIONS:

The air conditioner is designed to fit over an existing roof vent opening. When the vent is removed, it normally creates a 14" x 14" opening.

#### 2. OTHER LOCATIONS:

When no roof vent is available or another location is desired, the following is recommended:

- a. For one unit installation: The air conditioner should be mounted slightly forward of center (front to back) and centered from side to side.
- b. For two unit installations: Install one air conditioner 1/3 and one air conditioner 2/3's from front of RV and centered from side to side.

It is preferred that this air conditioner be installed in a relatively flat and level roof section measured with the RV parked on a level surface; however, up to 10° slant to either side, or front to back, is acceptable.

### 3. AFTER LOCATION SELECTION:

- a. Check for obstructions in the area where air conditioner will be installed.
- b. The roof must be designed to support 130 pounds when the RV is in motion. Normally a 200 lb. static load design will meet this requirement.
- c. Check inside the RV for air box obstructions. (i.e. door openings, room dividers, curtains, ceiling fixtures, etc.)

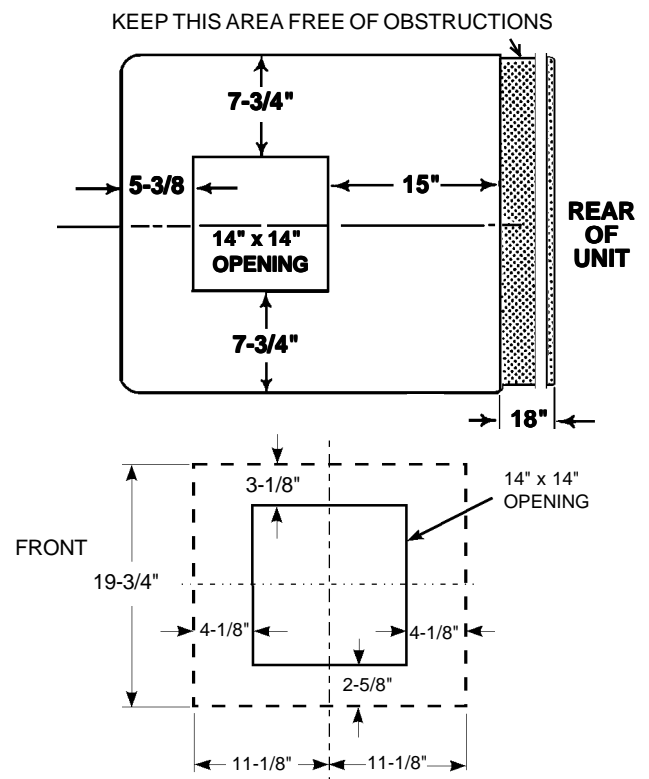

### C. ROOF PREPARATION

#### 1. ROOF VENT REMOVAL:

- a. Unscrew and remove the roof vent.
- b. Remove all caulking compound around opening.
- c. Seal all screw holes and seams where the roof gasket will be located. Use a good grade of all weather sealer.

2. **NEW OPENING:**  
(Installations Other Than Vent Openings)

**WARNING**

**DISCONNECT ALL POWER SUPPLIES AND THE POSITIVE (+) TERMINAL FOR THE SUPPLY BATTERY. FAILURE TO FOLLOW THIS INSTRUCTION MAY CREATE A SHOCK HAZARD.**

- A 14" x 14" opening must be cut through the roof and ceiling of the RV. It is recommended this opening be located between roof reinforcing members.
- Mark a 14" x 14" square on the roof and carefully cut the opening.
- Using the roof opening as a guide, cut the matching hole in the ceiling.

**CAUTION: There may be electrical wiring between the roof and ceiling.**

3. **OPENING PREPARATION:**

- If the opening exceeds 14-1/2" x 14-1/2", it will be necessary to install spacers.
- If the opening is less than 14" x 14", it must be enlarged.
- Route a copper 12 AWG, with ground, supply line from the fuse or circuit breaker box to the roof opening.
  - The power supply must be on a separate 20 amp Time Delay Fuse or HACR Circuit Breaker.
  - Wiring must comply with all National, State and Local wiring codes.
  - Make sure at least 20" of wire extend into the roof opening. This insures easy air conditioner attachment.
  - If vent fan was removed, the existing wire may be used provided it is of proper size and correctly fused.
- The opening must be framed to provide adequate support and prevent air from being drawn from the roof cavity. Lumber 3/4" thick or more and long enough to bridge the opening must be used. Remember to provide and entrance hole for the power supply wire.

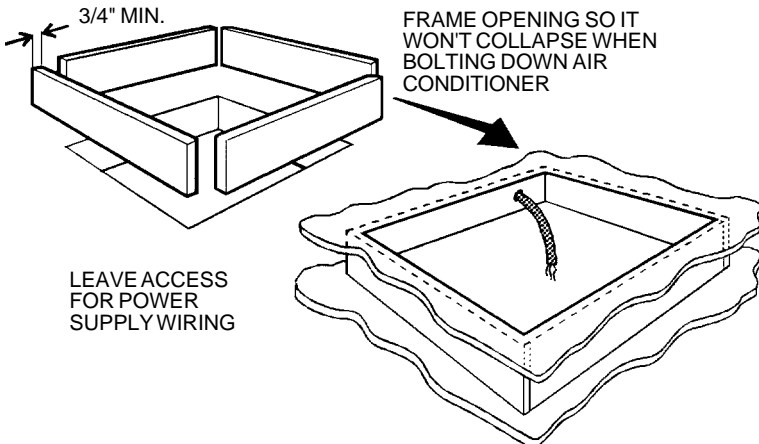

**NOTE: NEVER create a LOW SPOT on the roof where water will collect. Water standing around the air conditioner may leak into the RV interior.**

e. The 14" x 14" roof opening is part of the return air duct and must be finished in accordance with NFPA standard 501C, Standard for Recreational Vehicles, Section 2-7.

**D. PLACING THE AIR CONDITIONER ON THE ROOF**

- Remove the Air Conditioner from the carton and discard the carton.
- Place the air conditioner on the roof.

**CAUTION: Use care in lifting- this unit weights approximately 100 pounds.**

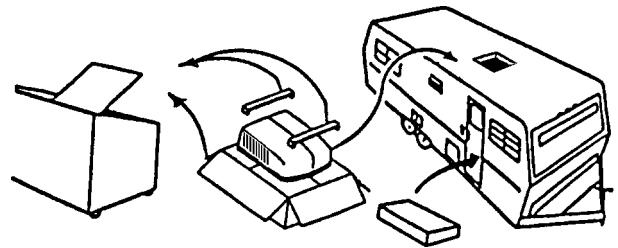

- Lift and place the unit over the prepared opening using the gasket as a guide. The condenser coil goes toward the rear of the RV.

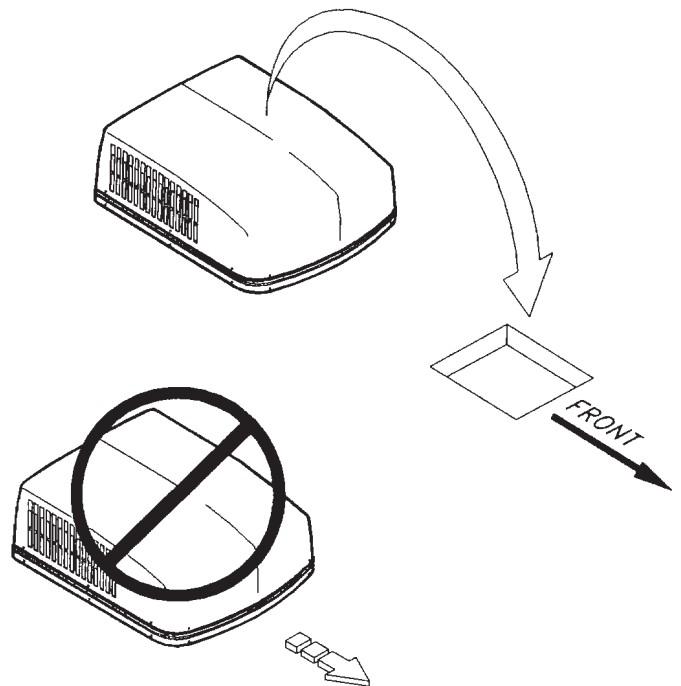

**CAUTION: DO NOT slide the unit. This may damage the neoprene gasket attached to the bottom and create a leaky installation.**

## MOUNTING PARTS

- A. (2) #10 x 1/2" long sharp point sheet metal screws.



- B. (4) 1/4" — #20 x 7" bolts



- C. (7) #8 x 5/8" long sharp point wood screws



- D. (4) #10 x 3/8" blunt point tapping screws



- E. (1) Romex connector



- F. (1) Machine screw, 3/8" long



- G. (2) #10 — 24 Hex nuts



- H. Cover plate



## AIR CONDITIONING UNIT

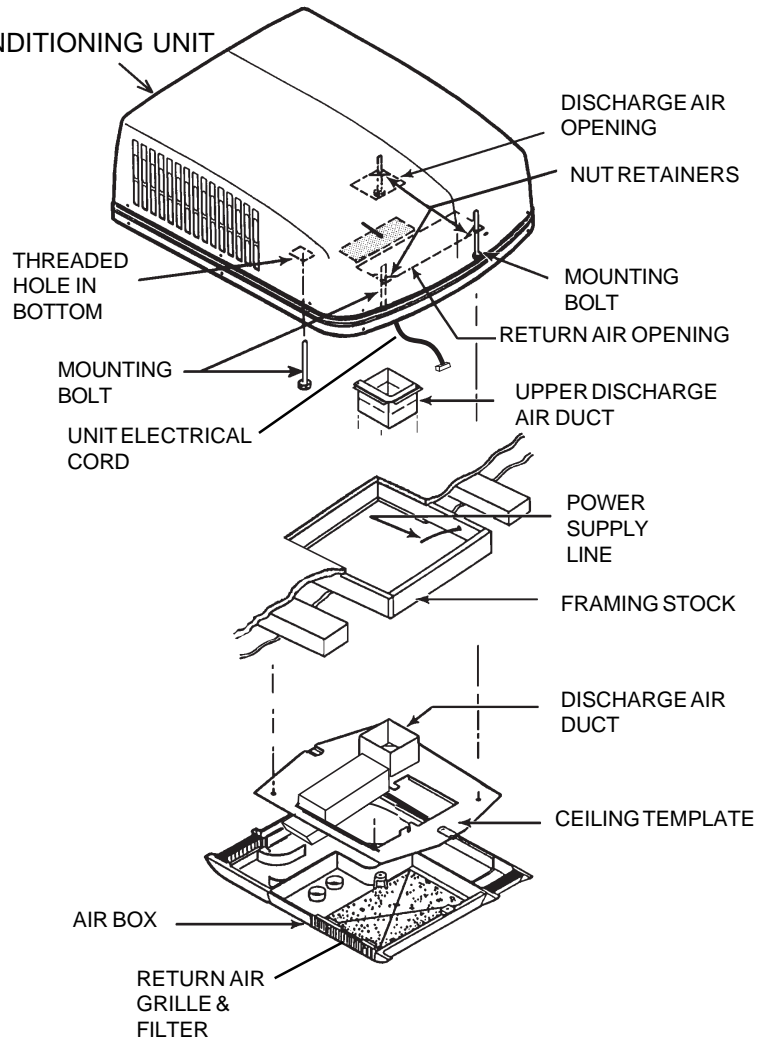

## AIR BOX WIRING DIAGRAM

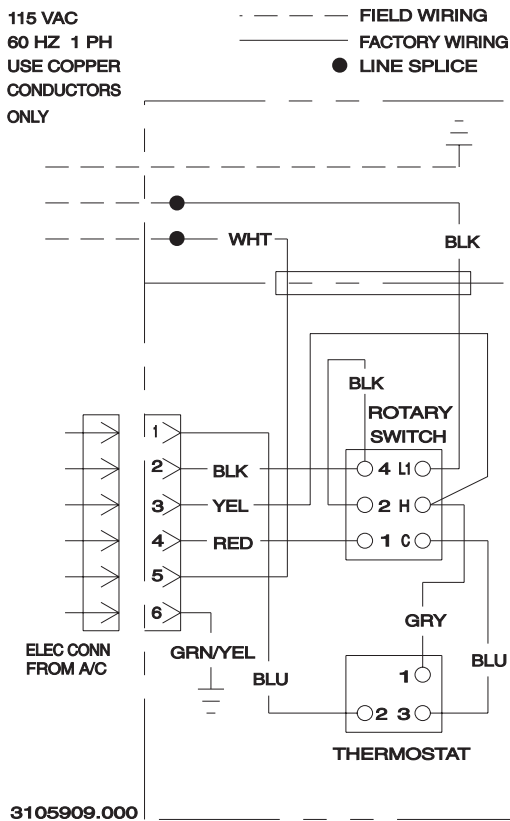

## ELECTRICAL BOX WIRING DIAGRAM

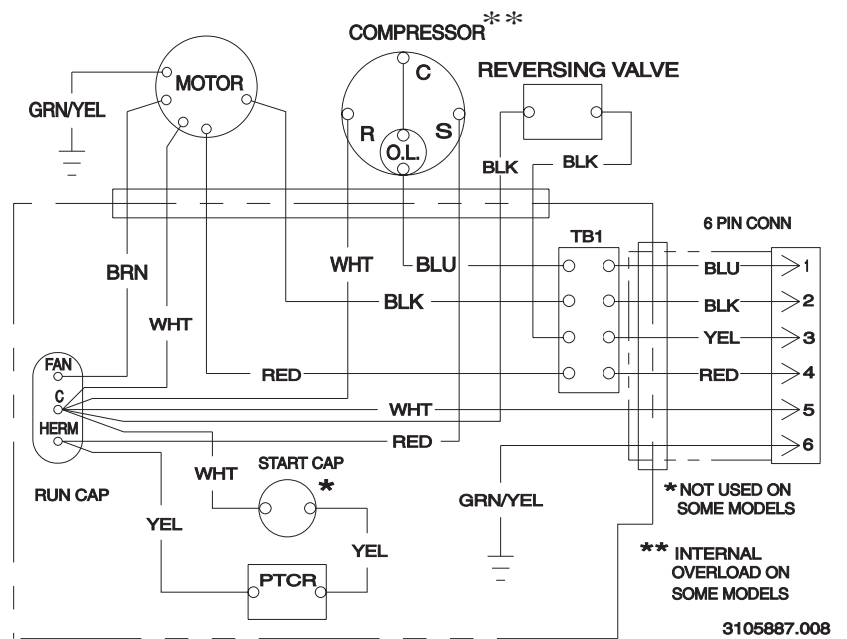

- Place the Air Box Kit inside the RV. This box contains mounting hardware for the air conditioner and will be used inside the RV.

This completes the outside work. Minor adjustments can be done from the inside if required.

## E. DISCHARGE DUCT AND CEILING TEMPLATE INSTALLATION

- Remove air box and mounting hardware from carton. The upper duct is shipped inside the lower duct which is part of the ceiling template.
  - Remove upper duct from ceiling template and locate it over blower discharge.

**NOTE: Edges without flanges install toward REAR and SIDE of opening.**

- Use two (2) sharp pointed #10 x 1/2" sheet metal screws (A) to hold duct to base pan. Holes provided in bottom of basepan for these screws to go into.

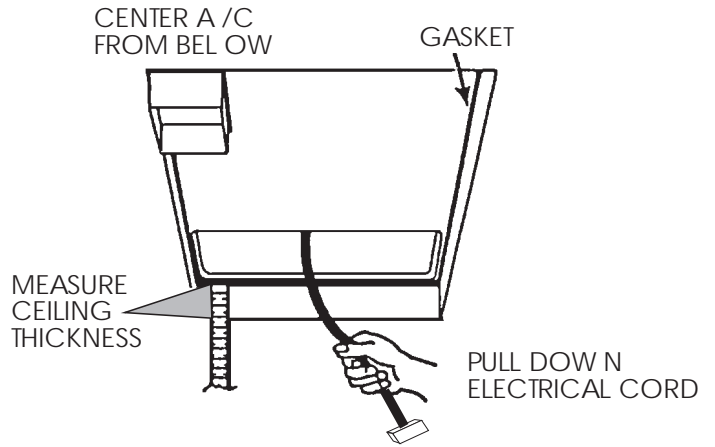
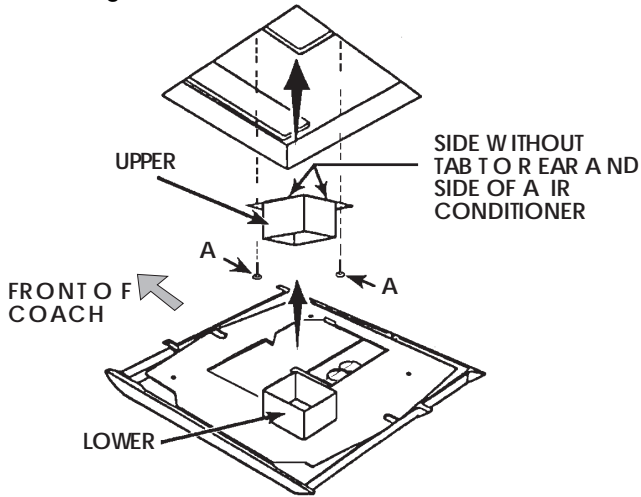

- Check for correct alignment and adjust the unit as necessary (Roof Gasket centers over 14" opening).
- Reach up into return air opening of the air conditioner and pull the unit electrical cord down for later connection.
- Measure the ceiling to roof thickness:
  - If distance is 1"-2", remove perforated tabs from both upper and lower ducts.
  - If distance is 2"-3", remove perforated tabs from bottom duct only.
  - If distance is 3"-4", install ducts as received.
  - If distance is 4"-6", use optional duct adaptor, Part No. 313606.000 and Bolt Kit, Part No. 3100895.006.
- Install ceiling template by sliding lower duct over upper duct.
- Start each mounting bolt by hand before tightening any of them. The four (4) threaded inserts in the base pan can be seen to aid in starting the bolts.

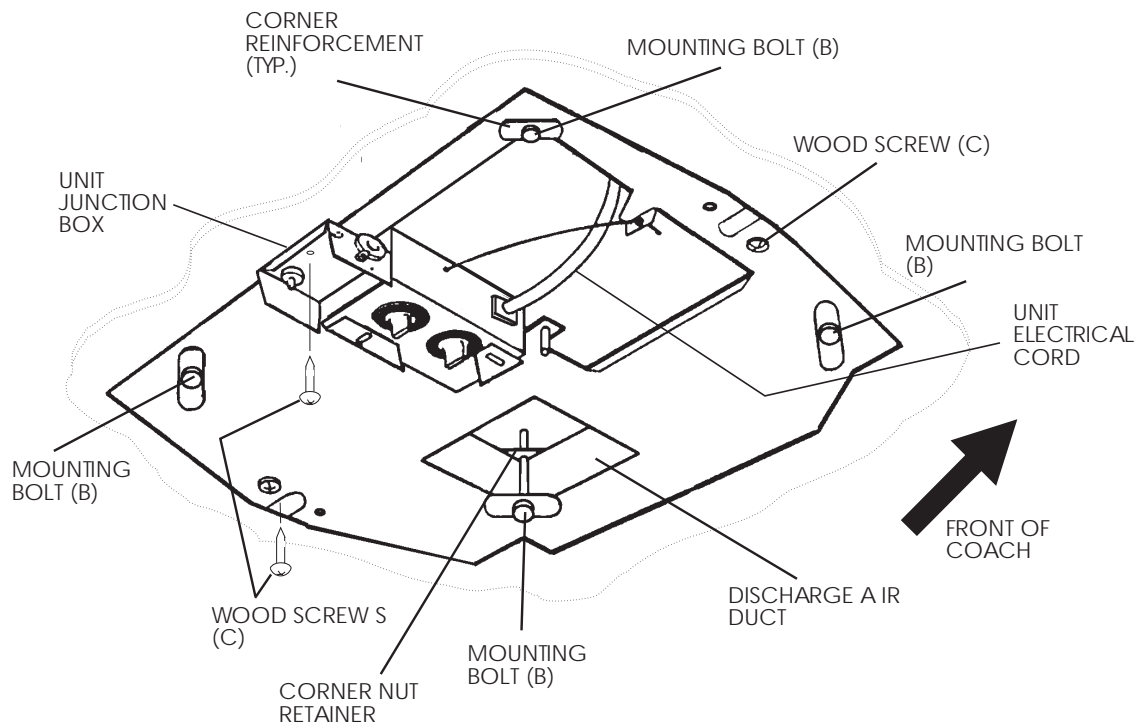



EVENLY TIGHTEN MOUNTING BOLTS TO A TORQUE OF 40 TO 50 INCH POUNDS.

This will compress the roof gasket to approximately 1/2". The bolts are self locking so over tightening is not necessary.

7. Install wood screws (C) in each end of ceiling template and into junction box. This insures a tight fit of air box to ceiling.

## F. CONNECTION OF POWER SUPPLY

**NOTE: All wiring must comply with the National Electrical Code and any State or Local Codes or regulations.**

1. Route supply line into junction box thru provided Romex Connector (E). Six (6) inch leads are sufficient for connection to unit wires and ground screws.
2. Connect white wire in junction box to white or neutral wire from supply line.

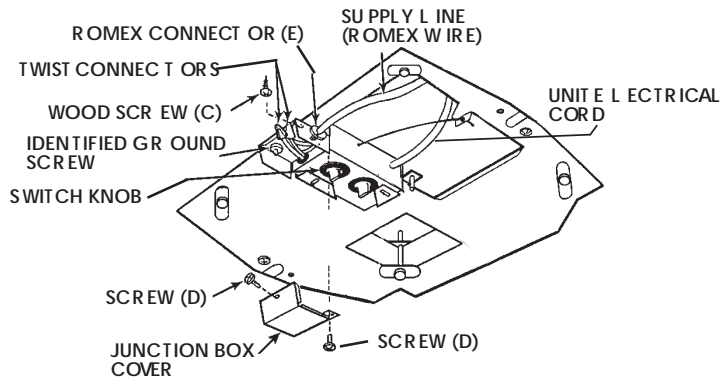

3. Connect black wire in junction box to black or hot wire from supply line.
4. Connect supply ground wire to identified ground screw in junction box.
5. Install junction box cover with two (2) blunt point screws (D).
6. Plug unit electrical cord into the mating connector on control box.

## G. INSTALL AIR BOX

1. Remove return air grille from air box by pulling out on push/pull fasteners.
2. NOTE: If optional heat package is to be installed, do so at this time, before the air box is installed. Follow instructions with heat package for its installation procedure.
3. Install air box over two (2) weld studs on ceiling template and secure with nuts (G).
4. Install machine screw (F) in round air box hole.

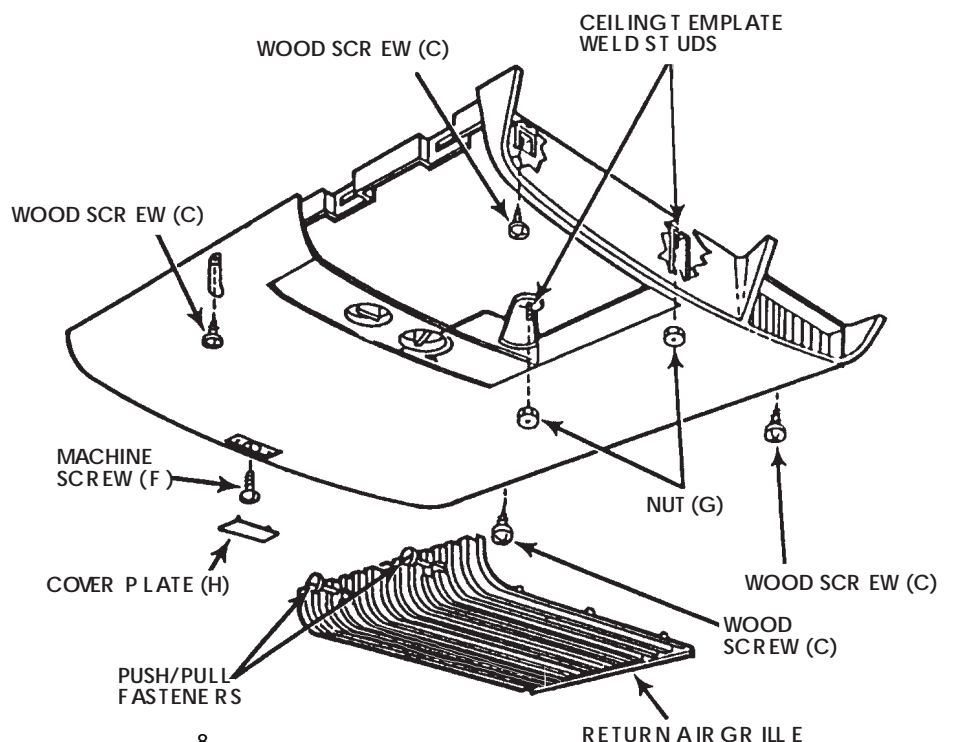

5. Install four (4) wood screws (C) that hold air box tight to ceiling.
6. Reinstall return air grille and snap cover plate (H) into air box.
7. The air conditioner installation is now complete. Turn on power to the unit for operational check. Please read Unit Operating Instructions before proceeding.

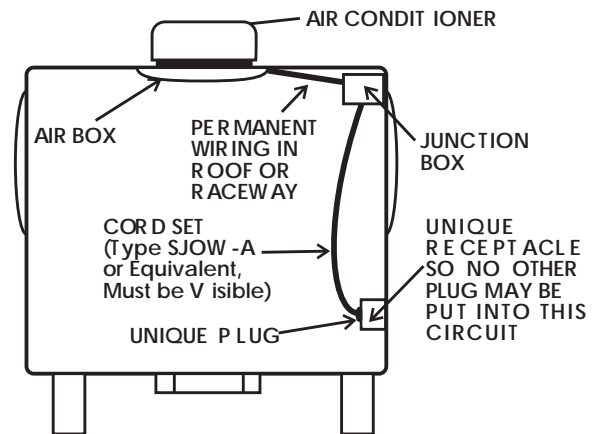

## H. INSTALLATION ON TENT CAMPER ROOF

1. The permanent wiring leading to unit junction box may originate in a flanged surface inlet located in roof section near the side wall.
2. A unique outlet receptacle for air conditioner should be located in the side wall of vehicle beneath the flanged surface inlet.
3. A cord set fabricated from an oil, water, and ozone resistant material, such as Type SJOW-A, shall be used to connect the flanged surface inlet and the air conditioning receptacle. This cord set shall be visible during use and shall not be installed in raceways or placed behind walls or cabinet panels.