

OWNER'S MANUAL
FOR ELECTRIC
HEAT EXCHANGER
WATER HEATERS
20 GALLON • VERTICAL

MODELS:

S1800, S1850, S1900, S1950

SAFETY INSTRUCTIONS

WARNING: When using electrical appliances, basic safety precautions to reduce the risk of fire, electric shock, or injury to persons should be followed, including:

1. READ ALL INSTRUCTIONS BEFORE USING THIS WATER HEATER.
2. This water heater must be grounded. Connect only to properly grounded outlet. See “GROUNDING INSTRUCTIONS” found on Page 4, Item 7.
3. Install or locate this water heater only in accordance with the provided installation instructions.
4. Use this water heater only for its intended use as described in this manual.
5. Do not use an extension cord set with this water heater. If no receptacle is available adjacent to the water heater, contact a qualified electrician to have one properly installed.
6. As with any appliance, close supervision is necessary when used by children.
7. Do not operate this water heater if it has a damaged cord or plug, if it is not working properly, or if it has been damaged or dropped.
8. This water heater should be serviced only by qualified service personnel. Contact nearest authorized service facility for examination, repair, or adjustment.

WARNING

This water heater is equipped with a heat exchanger. Extended engine coolant circulation through the heater may result in excessively hot water.

This water heater tank and heat exchanger is made of aluminum. Some engine manufacturers recommend that the cooling system be flushed periodically. Caustic chemicals are commonly used. DO NOT flush caustic chemicals (such as Nalcool) through your system with the heat exchanger hooked up or damage WILL occur to the heater.

If flushing is required by your engine manufacturer, you must isolate the heater from this process. After system flushing is complete and neutralized, you can then re-plumb the heater. Make sure recommended automotive type premixed ethylene glycol coolants such as Prestone, Xerex or Peak are used for replacement. Damage that occurs to the heater due to chemical reaction by caustic chemicals is not covered under warranty.

CAUTION

Hydrogen gas can be produced in a hot water system served by these heaters that have not been used for a long period of time (generally 2 weeks or more). Hydrogen gas is extremely flammable. To reduce the risk of injury under these conditions, it is recommended that the hot water faucet be opened for several minutes at the kitchen sink before using any electrical appliance connected to the hot water system. If hydrogen is present, there will probably be an unusual sound such as air escaping through the pipe as the water begins to flow. There should be no smoking or open flame near the faucet at the time it is open.

Small amounts of electric currents may move to your boat through your shore cord, causing galvanic damage to your water heater. To help prevent possible damage, a galvanic isolator is recommended. Galvanic corrosion is not covered under warranty.

NOTICE:

This temperature/pressure valve may weep during initial operation. This is normal. The valve will seat itself with use. A drain hose should be installed at this valve directed into the bilge.

If the boat is connected to the dockside water system, make sure to turn off the system at the dock when not attended. Also make sure a pressure regulator is used to control pressure.

OPERATION INSTRUCTIONS

1. Fill water system and completely fill tank.
2. Locate and turn remote electrical switch to “ON”.
3. Turn switch to “OFF” position prior to draining water system.
4. The temperature/pressure valve may weep during initial installation operation. This is normal. The valve will seat itself with use. NOTE: Do not operate water heater without element be submerged in water.

MAINTENANCE

1. Check heat exchanger lines for leaks at regular intervals. A leak in the system will cause coolant loss and may damage engine.
2. Flush tank periodically to help prevent buildup of deposits.
3. Protect against damage from freezing temperatures, (32°F or less).

Please review against the following:

- a.) Drain tank by fully opening drain valve. Open T & P valve to help relieve vacuum in tank. (See item 2 in exploded view)
- b.) It is recommended that you winterize your fresh water system. First, complete step 3a, then follow the instructions of your local supplier regarding chemicals to use and how to use them.

CAUTION:

If heater has been run without water and now fails to work, push electric reset button high limit switch under the wire access cover before calling for service.

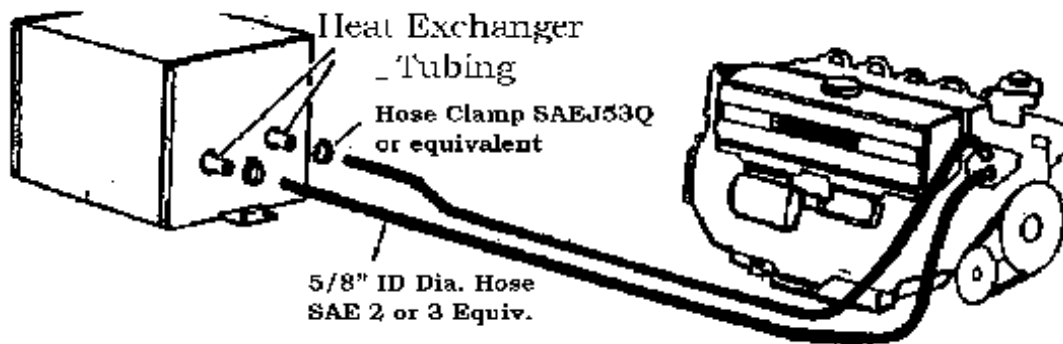

INSTALLATION

NOTE: DO NOT INSTALL THE WATER HEATER ON ITS SIDE OR UPSIDE DOWN.

1. Locate water heater at engine level as close to engine as possible.
2. Secure mounting brackets to structure with eight #12 minimum screws or 1/4-20 minimum cap screws and nuts.
3. Connect cold water supply and hot water outlet to heater as marked, 1/2" NPT fittings
4. Connect heat exchanger system described in figure above. Make sure coolant system is completely purged of air and full of coolant before operating.
5. The pressure temperature relief valve is factory installed. The pressure relief valve shall limit the pressure to 127.5 PSI (879.3 KPA) minimum, 150 PSI (1034.2 KPA) maximum.

The valve must be oriented, provided with tubing, or otherwise installed so that the discharge can exit no more than 6 inches above, or at any distance below the structural floor and cannot contact any live electrical part.

Install replacement temperature and pressure protective equipment required by local codes, but not less than a combination temperature and pressure relief valve certified as meeting the requirements for relief valves and automatic gas shutoff devices for hot water supply systems, ANSI Z21.22 by a nationally recognized testing laboratory that maintains periodic inspection of production of listed equipment or materials.

6. Connect the electrical supply by a qualified electrician. The electrical supply shall be permanent wiring, armored cable or conduit, per national electrical code NFPA 70, with a minimum capacity of 1500 watts. On 120 volt circuits, use a UL approved 15 amp circuit breaker. On 240 volt circuits, use a 10 amp approved circuit breaker per leg.
7. **GROUNDING INSTRUCTIONS:** The supply ground shall be connected to the green wire located in the water heater wiring compartment. Do not place the switch in the ground circuit.

8. RESET INSTRUCTIONS: The heater is equipped with a high limit switch that can be manually reset. If the limit switch activates, proceed as follows:
- Turn power off at main power panel or remote switch
 - Remove wiring access cover
 - Depress red button on high temperature limit switch
 - Replace cover and turn power on
 - If temperature limit switch reactivates, contact a Seaward Products authorized service center.

WIRING DIAGRAM FOR 120V

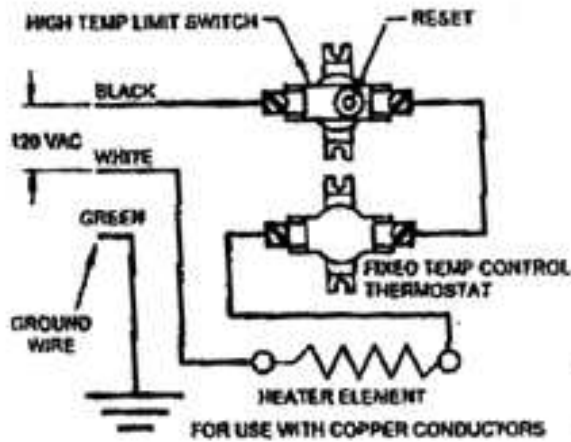

CAUTION: TO REDUCE RISK OF SHOCK OR FIRE, USE ONLY ON A UTILITY SYSTEM HAVING A MAXIMUM 120/250 VOLT, THREE WIRE SYSTEM.

120 VOLT AC

WIRING DIAGRAM FOR 240V

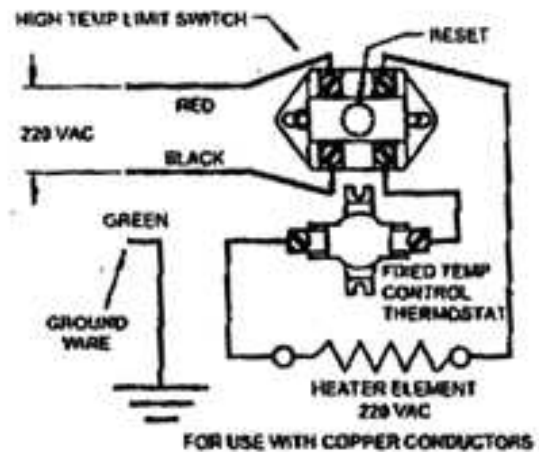

240 VOLT AC