

Installation/Operators Manual
For use with WFCO T-30
Automatic Transfer Switch



Distributed in the U.S.A. and Canada by
CHENG USA, INC.
Sales (574) 294-8997
Warranty Service (877) 294-8997
Fax (574) 294-8698



OEM Installation of the T-30 Automatic Transfer Switch

T-30 is an automatic transfer switch for 30 Amp AC service. It is installed onto a WF-8900 Series Power Center. To minimize voltage drop across the wire, install the Power Center with the Transfer Switch as close to the generator and shore power cord entrance as possible.

Do not install close to appliances that are a source of heat or water (such as water heaters, furnaces, and under refrigerators). It is not designed for mounting in humid wet locations. The T-30 must be protected from direct contact with water and debris.

⚠ WARNING ⚠

This unit employs components that tend to produce arcs or sparks. To prevent fire or explosion, do not install in compartments containing batteries or flammable materials (LP gas). Risk of electric shock: more than one disconnect switch may be required to de-energize the equipment before servicing.

⚠ CAUTION ⚠

Do not mount in zero-clearance compartment. Overheating may result. The T-30 must be installed by a qualified electrician.

Do not drill through the metal housing, debris and metal shavings can interfere with the operation of the transfer switch. For wiring use the existing knockouts.

Operation:

When the T-30 transfer switch (or the Power Center) is plugged into the shore power, the T-30 will automatically provide AC power to all AC appliances. To operate your appliances from the on board generator simply start the generator and the T-30 will (after 20-30 seconds) automatically transfer the electrical power to AC appliances. The time delay of 20-30 seconds allows the generator voltage to stabilize.

INSTALLATION INSTRUCTIONS

1



Wiring Instructions

This Automatic Line/Generator Switch is rated for use on circuits capable of delivering 105 - 130 Vac 60 Hz 30 Aac.

All field wires used have to be rated to at least 105 °C. All grounds are connected inside of the T-30.

Note: Select a proper wire type, gage, and wire connector according to the NEC requirements.

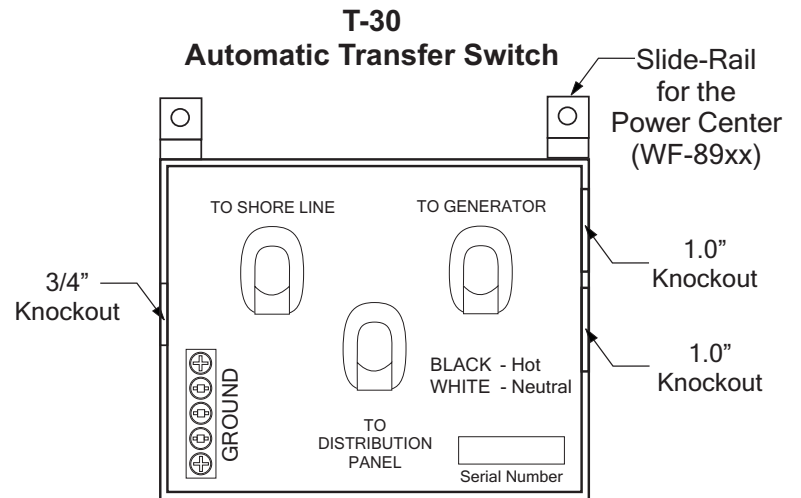

WARNING: DIP switch on the "Timing Board" bypasses the time delay and is only used for testing during the manufacturing process and should not be tampered with. Bypassing the timing board will eliminate the time for the generator voltage to stabilize (default DIP switch position is "OFF" or down).

WIRING INSTRUCTIONS

2



**Consumer Limited Warranty
For
WFCO Electronic Products**

WFCO extends, to the original owner a Two Year Limited Product Warranty. This Warranty is in effect from the date of original purchase for a period of two (2) years. This Limited Warranty is extended specifically for and is limited to recreational vehicle application and is only valid within the continental United States, Alaska, Hawaii and the provinces of Canada. WFCO warrants, to the owner, that its products are free from defects in material and workmanship under normal use and service based on its intended use and function. This Warranty is limited to the repair or replacement, at WFCO's discretion, of any defective parts or defective assembly. Any implied warranties of merchantability or fitness for intended use are limited in duration unless applicable State Law provides otherwise. You may have other rights as specified by each individual state.

EXCLUSIONS and LIMITATION

The OEM Warranty specifically does not apply to the following:
any WFCO product that has been repaired or altered by any unauthorized person; any damage caused by misuse, faulty installation, testing, negligence or accident or any WFCO product installed in a commercial vehicle;
any WFCO product whose serial number has been defaced, altered or removed;
any WFCO product whose installation has not been in accordance to the WFCO written instruction and any consequential damages arising from the loss of use of the product including but not limited to: inconvenience, loss of service, loss of revenue, loss or damage to personal property and cost of all services performed in removing or replacing the WFCO product. Specifications are subject to change without notice or obligation.

CONSUMER WARRANTY CLAIM PROCEDURE

Upon determination and validation by an authorized OEM dealer that a WFCO product has a defect, the dealer shall contact the WFCO warranty service number (877) 294-8997 and obtain a return goods authorization (RGA) number. This number shall appear on all correspondence with warranty service. Upon validation of the warranty WFCO shall replace or repair the product with a like product. The RGA number shall be placed on the outside of the carton used to return the product for ease of identification. Do not mark directly on the product. The product must be packaged properly to avoid further damage to the product which could cause a non-warrantable condition.

LIMITED WARRANTY

3