

GENERAC®

POWER SYSTEMS, INC.

Owner's Manual and Installation Instructions

Air-cooled Recreational Vehicle Generator

- Model Nos: 00940-2 & 00941-2
IMPACT-36 plus II with Inverter

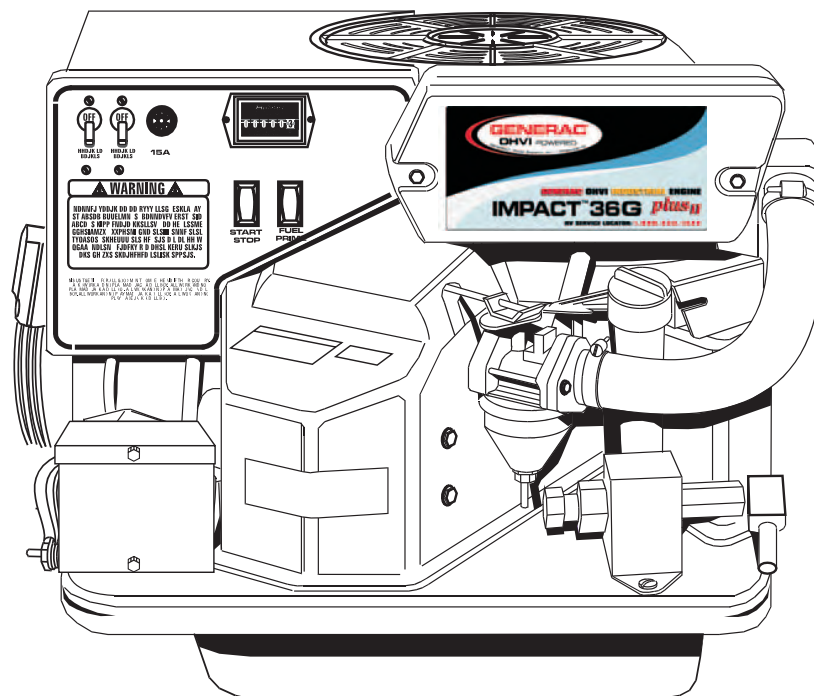

INTRODUCTION

Thank you for purchasing this generator by Generac Power Systems, Inc. This model is designed and manufactured to supply electrical power for recreational vehicles.

◆ READ THIS MANUAL THOROUGHLY

If you do not understand any portion of this manual, contact Generac or your nearest Generac Authorized Service Dealer for starting, operating, and servicing procedures.

Throughout this publication, and on tags and decals affixed to the generator, DANGER, WARNING, CAUTION, and NOTE blocks are used to alert you to special instructions about a particular operation that may be hazardous if performed incorrectly or carelessly. Observe them carefully. Their definitions are as follows:



After this heading, you can read instructions that, if not strictly complied with, will result in personal injury or property damage.



After this heading, you can read instructions that, if not strictly complied with, may result in personal injury or property damage.



After this heading, you can read instructions that, if not strictly complied with, could result in damage to equipment and/or property.

NOTE:

After this heading, you can read explanatory statements that require special emphasis.

These safety warnings cannot eliminate the hazards that they indicate. Common sense and strict compliance with the special instructions while performing the service are essential for preventing accidents.

Four commonly used safety symbols accompany the DANGER, WARNING, and CAUTION blocks. Here are the types of information indicated by each symbol:

 This symbol points out important safety information that, if not followed, could endanger personal safety and/or property to self and others.

 This symbol points out potential explosion hazard.

 This symbol points out potential fire hazard.

 This symbol points out potential electrical shock hazard.

The operator (i.e., the driver) is responsible for the proper and safe use of the vehicle and its equipment, and for the safety of all vehicle occupants. Before using this equipment, we strongly recommend that the operator read this manual and thoroughly understand all instructions. We also strongly recommend instructing other occupants in the vehicle to properly start and operate the generator. This prepares them to operate the equipment in case of an emergency.

◆ CONTENTS

This manual contains pertinent owner's information, including warranty, electrical diagrams, exploded views, and lists of repair parts for generator models 00940-2 and 00941-2. In addition, the latter portion of this manual contains information necessary for the proper installation of these generators.

◆ OPERATION AND MAINTENANCE

It is the operator's responsibility to perform all safety checks, to make sure that all maintenance for safe operation is performed promptly, and to have the equipment checked periodically by a Generac Authorized Service Dealer. Normal maintenance service and replacement of parts are the responsibilities of the owner/operator and, as such, are not considered defects in materials or workmanship within the terms of the warranty. Individual operating habits and usage contribute to the need for maintenance service.

Proper maintenance and care of your generator minimize problems and operating expenses. See your Generac Authorized Service Dealer for service aids and accessories.

◆ HOW TO OBTAIN SERVICE

When your generator requires servicing or repairs, simply contact a Generac Authorized Service Dealer for assistance. Service technicians are factory-trained and are capable of handling all of your service needs.

When contacting a Generac Authorized Service Dealer or the factory about parts and service, always supply the complete model number and serial number of your unit, as given on its data decal, which is located on your generator.

Model No. _____ Serial No. _____

AUTHORIZED SERVICE DEALER LOCATION

To locate the GENERAC AUTHORIZED SERVICE
DEALER nearest you, please call this number:

1-800-333-1322

ONLY DEALER LOCATION INFORMATION
CAN BE OBTAINED AT THIS NUMBER.

Part I – Owner’s Manual

Introduction**Inside Front Cover**
 Read This Manual ThoroughlyIFC
 ContentsIFC
 Operation and MaintenanceIFC
 How to Obtain ServiceIFC
 Authorized Service Dealer Locator NumberIFC

Safety Rules**2**

Section 1 – General Information**4**

1.1 Generator Identification4
 1.1.1 Impact-36G plus Features4
 1.1.2 Impact-36LPG plus Features5
 1.1.3 Inverter Features6

1.2 Generator Applicability7

1.3 Safety7

1.4 Generator Control Panel7
 1.4.1 Fuel Primer7
 1.4.2 Start/Stop Switch7
 1.4.3 Fuse7
 1.4.4 Circuit Breakers7
 1.4.5 Hour Meter8

1.5 Automatic Choke (Gasoline Only)8
 1.5.1 Choke Solenoid (Gasoline Only)8
 1.5.2 Prechoke (Gasoline Only)8

1.6 Engine Protective Devices8
 1.6.1 Automatic Low Oil Pressure Shutdown8
 1.6.2 High Temperature Shutdown8
 1.6.3 Overspeed8
 1.6.4 Low Voltage8

Section 2 – Operation**9**

2.1 Before Starting the Engine9
 2.1.1 Installation9
 2.1.2 Engine Lubrication9
 2.1.3 Fuel Supply9
 2.1.4 Cooling and Ventilating Air9
 2.1.5 Engine Exhaust Gas9

2.2 Starting the Generator9

2.3 Stopping the Generator10

2.4 Applying Loads to Generator10
 2.4.1 Letting the Engine Stabilize10

2.5 Attention Required After Submersion10

2.6 Operation in High Grass or Brush10

2.7 Operating Precautions10

2.8 Fuel Requirements (Gasoling Units)10

2.9 Fuel Requirements (LP Units)11

2.10 Engine Oil Requirements11

2.11 Gas Generator Specifications11

2.12 LP Generator Specifications11

2.13 Engine Specifications11

Section 3 – Maintenance**12**

3.1 Maintenance12

3.2 Checking the Engine Oil Level12

3.3 Change Engine Oil12

3.4 Change Oil Filter12

3.5 Engine Air Cleaner13

3.6 Clean Air Intake Screen13

3.7 Engine Spark Plug13

3.8 Fuel Filter13

3.9 Inverter14

3.10 Cleaning the Generator14

3.11 Battery14
 3.11.1 Once Weekly14
 3.11.2 Every Six Months14

3.12 Service and Adjustments14
 3.12.1 Engine Speed14

3.13 Adjusting the Carburetor14

3.14 Adjusting Valve Clearance15

3.15 Major Service Manual15

3.16 Exercising the Generator15

3.17 Out of Service Protection15

3.18 Return Unit to Service After Storage15

Notes**16**

Part II – Installation Instructions

Safety Rules**18**

Section 1 – General Information**20**

1.1 Purpose and Scope of the Manual20

1.2 Safety20

1.3 Standards Booklets20

1.4 Equipment Description20

1.5 Engine Generator Operating Speed20

Section 2 – Installation**21**

2.1 Location and Support21
 2.1.1 Generator Location21
 2.1.2 Generator Support21
 2.1.3 Suspended Mounting21
 2.1.4 Generator Restraint22

2.2 Generator Compartments22
 2.2.1 Compartment Size23
 2.2.2 Compartment Construction23
 2.2.3 Sound Insulating Materials24
 2.2.4 Compartment Floor Cutouts24
 2.2.5 Acoustics25

2.3 Cooling and Ventilating Air25
 2.3.1 Generator Airflow25
 2.3.2 Cooling Air Inlet Openings26
 2.3.3 Compensating for Restrictions27
 2.3.4 Inverter Location27
 2.3.5 Testing the Installation27

2.4 Gasoline Fuel System27
 2.4.1 Fuel Tank27
 2.4.2 Generator Fuel Supply Lines28

2.5 Propane Gas Fuel System28
 2.5.1 Parts Not Included in Fuel System28
 2.5.2 Some Important Considerations29
 2.5.3 Vapor Withdrawal29
 2.5.4 Primary Regulator29
 2.5.5 Gaseous Carburetion29
 2.5.6 Fuel Supply Lines30
 2.5.7 Excess Flow Valve30
 2.5.8 Leakage Tests30

2.6 Exhaust System30
 2.6.1 Muffler and Spark Arrestors30
 2.6.2 Type of Exhaust System31
 2.6.3 Exhaust System Safety31

2.7 Electrical Connections31
 2.7.1 Wiring32
 2.7.2 Generator AC Connection System32
 2.7.3 Isolating Different Power Sources32
 2.7.4 Power Supply Cord32
 2.7.5 Ground Fault Circuit Interrupters32
 2.7.6 Sensing Harnesses34

2.8 Battery Installation34
 2.8.1 Recommended Battery34
 2.8.2 Battery Cables34
 2.8.3 Battery Cable Connections35
 2.8.4 Battery Compartment35

2.9 Optional Accessories35
 2.9.1 Remote Plug-in Receptacle35
 2.9.2 Remote Start/Stop Panel35

Section 3 – Post-installation Startup Checks**36**

3.1 Post Installation Tests36

3.2 Before Initial Startup36

3.3 Initial Start36

3.4 Testing Under Load36

3.5 Installation Checklist37

Section 4 – Troubleshooting**38**

4.1 Troubleshooting Guide38

Section 5 – Electrical Data**39**

Section 6 – Exploded Views and Parts Lists**42**

Section 7 – Warranty**52**



SAVE THESE INSTRUCTIONS – *The manufacturer suggests that these rules for safe operation be copied and posted in potential hazard areas of the recreational vehicle. Safety should be stressed to all operators and potential operators of this equipment.*



WARNING:



The engine exhaust from this product contains chemicals known to the state of California to cause cancer, birth defects, or other reproductive harm.

Study these SAFETY RULES carefully before installing, operating, or servicing this equipment. Become familiar with this manual and with the unit. The generator can operate safely, efficiently, and reliably only if it is properly installed, operated, and maintained. Many accidents are caused by failing to follow simple and fundamental rules or precautions.

Generac cannot possibly anticipate every possible circumstance that might involve a hazard. The warnings in this manual, and on tags and decals affixed to the unit, are, therefore, not all-inclusive. If you use a procedure, work method, or operating technique that Generac does not specifically recommend, you must satisfy yourself that it is safe for you and others. You also must make sure the procedure, work method, or operating technique that you choose does not render the generator unsafe.

— DANGER —

Despite the safe design of this generator, operating this equipment imprudently, neglecting its maintenance, or being careless can cause possible injury or death. Permit only responsible and capable persons to operate and maintain this equipment.

Parts of the generator are rotating and/or hot during operation. Exercise care near running generators.

Potentially lethal voltages are generated by these machines. Ensure all steps are taken to render the machine safe before attempting to work on the generator.

GENERAL HAZARDS

- For safety reasons, Generac recommends that the installation, initial startup, and maintenance of this equipment be performed by a Generac Authorized Service Dealer.
- The engine exhaust fumes contain carbon monoxide, which can be DEADLY. This dangerous gas, if breathed in sufficient concentrations, can cause unconsciousness or even death. Thus, the exhaust system must be installed properly, in strict compliance with applicable codes and standards. Following installation, you must do nothing that might render the system unsafe or in noncompliance with such codes and standards. The generator compartment must be completely vapor-sealed from the vehicle interior. There must be no possibility of exhaust fumes entering the vehicle interior. Never operate this equipment with a leaking or defective exhaust system.
- Keep hands, feet, clothing, etc., away from drive belts, fans, and other moving or hot parts. Never remove any drive belt or fan guard while the unit is operating.
- Adequate, unobstructed flow of cooling and ventilating air is critical to correct generator operation and is required to expel toxic fumes and fuel vapors from the generator compartment. Without sufficient cooling airflow, the engine/generator quickly overheats, which seriously damages the generator. Do not alter the installation or permit even partial blockage of ventilation provisions, as this can also seriously affect the safe operation of the generator.
- When working on this equipment, remain alert at all times. Never work on the equipment when you are physically or mentally fatigued.
- Inspect the generator regularly, and contact your nearest Generac Authorized Service Dealer immediately for parts needing repair or replacement.
- Before performing any maintenance on the generator, disconnect its battery cables to prevent accidental startup. First, disconnect the cable from the battery post, indicated by a NEGATIVE, NEG, or (-). Reconnect this cable last.
- Never use the generator, or any of its parts, as a step. Stepping on the unit can stress and break parts, resulting in dangerous operating conditions due to leaking exhaust gases, fuel leakage, oil leakage, etc.
- Never insert any tool or other object through openings in the generator interior, even if the unit is not running. You might seriously injure yourself or damage the equipment.



ELECTRICAL HAZARDS

- The generator covered by this manual produces dangerous electrical voltages and can cause fatal electrical shock. Avoid contact with bare wires, terminals, connections, etc., while the unit is running. Before operating the generator, ensure all appropriate covers, guards, and barriers are in place. If you must work around an operating unit, stand on an insulated, dry surface to reduce shock hazard.
- Do not handle any kind of electrical device while standing in water, while barefoot, or while hands or feet are wet. **DANGEROUS ELECTRICAL SHOCK MAY RESULT.**
- During installation onto the vehicle, have the generator properly grounded (bonded), either by solid mounting to the vehicle frame or chassis, or by means of an approved bonding conductor. **DO NOT** disconnect the bonding conductor, if so equipped. **DO NOT** reconnect the bonding conductor to any generator part that might be removed or disassembled during routine maintenance. If the grounding conductor must be replaced, use only a flexible conductor that is of No. 8 American Wire Gauge (AWG) copper wire minimum.
- In case of an accident caused by electric shock, immediately shut down the source of electrical power. If this is not possible, attempt to free the victim from the live conductor. **AVOID DIRECT CONTACT WITH THE VICTIM.** Use a nonconducting implement, such as, a dry rope or board, to free the victim from the live conductor. If the victim is unconscious, apply first aid and get immediate medical help.
- Never wear jewelry when working on this equipment. Jewelry can conduct electricity, resulting in electric shock, or may get caught in moving components, causing, injury.

FIRE HAZARDS

- For fire safety, the generator must be installed and maintained properly. Installation must always comply with NFPA 70 (latest edition), “National Electrical Code”, Article 551, and NFPA 1192 (latest edition), “Standard for Recreational Vehicles”, along with all applicable codes, standards, laws, and regulations. Adhere strictly to local, state, and federal electrical and building codes. Comply with regulations the Occupational Safety and Health Administration (OSHA) has established. Also, ensure that the generator is installed in accordance with the manufacturer’s instructions and recommendations. After proper installation, do nothing that might alter the installation and render the unit in noncompliance with the aforementioned codes, standards, laws, and regulations.
- Keep a fire extinguisher in the vehicle at all times. Extinguishers rated “ABC” by the National Fire Protection Association are appropriate for use on the recreational vehicle generator electrical system. Keep the extinguisher properly charged and be familiar with its use. If you have any question pertaining to fire extinguishers, consult your local fire department.

EXPLOSION HAZARDS

- Do not smoke around the generator. Wipe off any fuel or oil spills immediately. Ensure that no combustible material is left in the generator compartment, or on or near the generator, as **FIRE** or **EXPLOSION** may result. Keep the area surrounding the generator clean and free of debris.
- All fuel types are potentially **FLAMMABLE** and/or **EXPLOSIVE** and should be handled with care. Comply with all laws regulating the storage and handling of fuels. Inspect the unit’s fuel system frequently and correct any leaks immediately. Before placing this equipment into service, the fuel supply lines must be properly installed, purged, and leak-tested according to applicable fuel-gas codes.

1.1 GENERATOR IDENTIFICATION

Please record the following information from the generator DATA DECAL or information decal, located below the user control panel.

- | | |
|-----------------------|------------------------|
| 1. Model Number _____ | 2. Serial Number _____ |
| 3. kW Rating _____ | 4. Rated Voltage _____ |
| 5. Phase _____ | 6. Hertz _____ |

◆ 1.1.1 IMPACT-36G PLUS II FEATURES

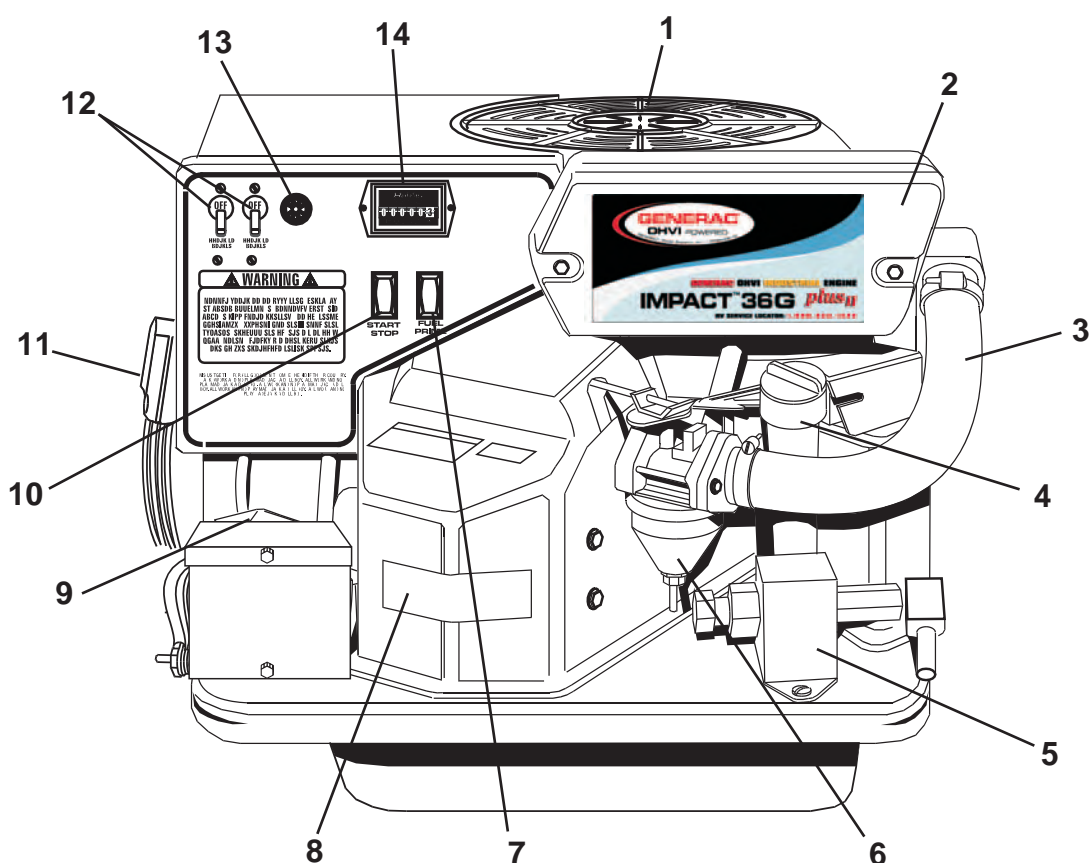

REFERENCE NUMBER IDENTIFICATION

- | | |
|---------------------------------|-------------------------------|
| 1. Generator Air Intake Screen | 8. Data Decal |
| 2. Air Cleaner | 9. 12 Volt Battery Connection |
| 3. Air Intake Tube | 10. Engine Start/Stop Switch |
| 4. Oil Dipstick and Filler Tube | 11. Generator DC Output Leads |
| 5. Fuel Pump | 12. Circuit Breaker |
| 6. Gasoline Carburetor | 13. Fuse |
| 7. Fuel Primer Switch | 14. Hour Meter |

Please record the following information from the generator DATA DECAL or information decal, located below the user control panel.

- | | |
|-----------------------|------------------------|
| 1. Model Number _____ | 2. Serial Number _____ |
| 3. kW Rating _____ | 4. Rated Voltage _____ |
| 5. Phase _____ | 6. Hertz _____ |

◆ **1.1.2 IMPACT-36LPG PLUS II FEATURES**

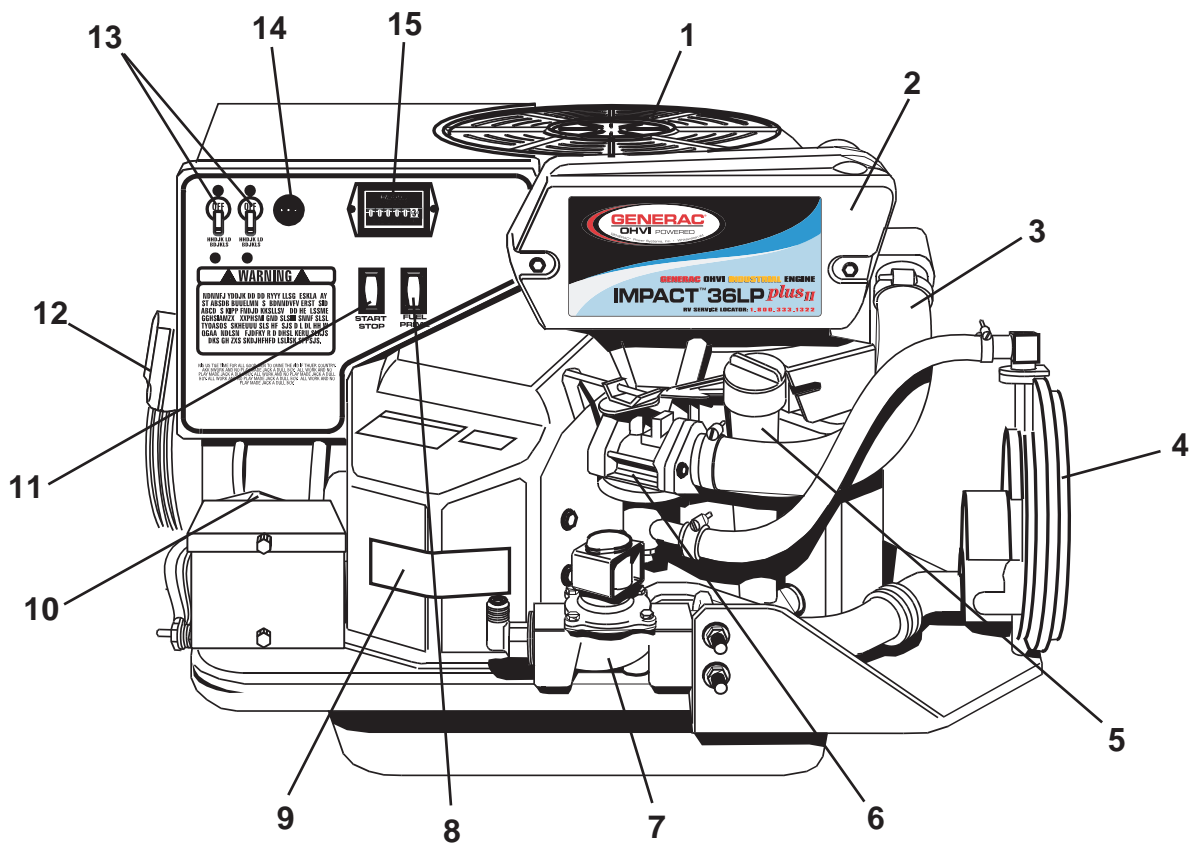

REFERENCE NUMBER IDENTIFICATION

- | | |
|---------------------------------|--------------------------------|
| 1. Generator Air Intake Screen | 9. Data Decal |
| 2. Air Cleaner | 10. 12 Volt Battery Connection |
| 3. Air Intake Tube | 11. Engine Start/Stop Switch |
| 4. LP Fuel Regulator | 12. Generator DC Output Leads |
| 5. Oil Dipstick and Filler Tube | 13. Circuit Breaker |
| 6. LP Carburetor | 14. Fuse |
| 7. LP Fuel Solenoid | 15. Hour Meter |
| 8. Fuel Primer Switch | |

◆ 1.1.3 INVERTER FEATURES (PART NO. 0D4885)

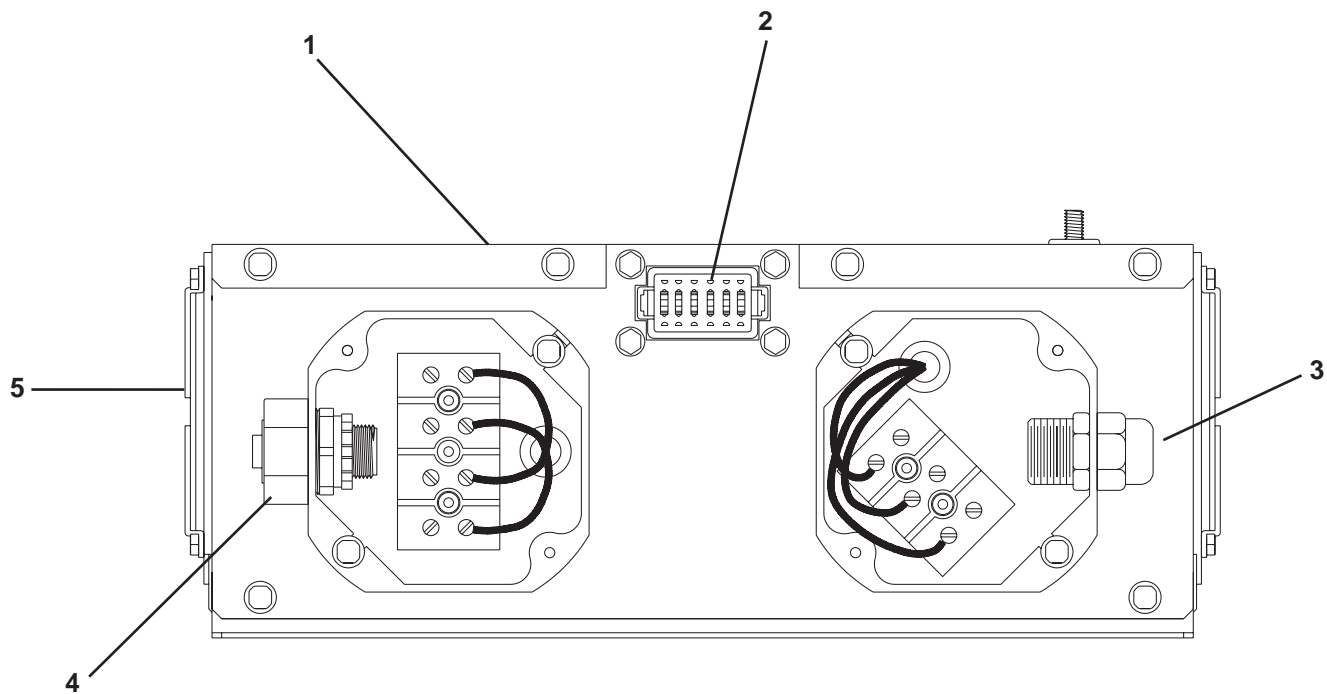

REFERENCE NUMBER IDENTIFICATION

- | | |
|-----------------------|----------------|
| 1. Inverter | 4. DC Input |
| 2. 12 Pin Connection | 5. Cooling Fan |
| 3. Customer AC Output | |

1.2 GENERATOR APPLICABILITY

These generators have been designed and manufactured for supplying electrical power for recreational vehicles. You should not modify the generator or use it for any application other than for what it was designed. If there are questions pertaining to its application, write or call the factory. Do not use the unit until you have been advised by a competent authority.

⚠ DANGER ⚠



For fire safety, the generator must have been properly installed in compliance with (1) ANSI 119.2-1975/NFPA 501C-1974 “Standard for Recreational Vehicles”, Part III, “Installation of Electrical Systems.” The generator also must have been installed in strict compliance with the manufacturer’s detailed installation instructions. After installation, do nothing that might render the unit in non-compliance with such codes, standards and instructions.

This generator has been designed to work with an inverter (P/N OD4885). The inverter changes the voltage from the generator from a DC to an AC voltage. This generator will not operate properly without the inverter box connected. All repairs of the inverter must be handled by an authorized service dealer (see Page 12 in “Maintenance”).

You can use this generator to supply electrical power for operating 120 volts, single phase, 60 Hertz, electrical loads. These loads can require up to 3400 watts (3.4 kW) for the Impact-34 plus II, or 3600 watts (3.6 kW) for the Impact-36 plus II. The maximum current at 120 volts is 28.3 amperes for the Impact-34 plus II, or 30 amperes for the Impact-36 plus II.

⚠ CAUTION ⚠



CAUTION: Do not overload the generator. Some installations may require that electrical loads be alternated to avoid overloading. Applying excessively high electrical loads may damage the generator and may shorten its life. Add up the rated watts of all electrical lighting, appliance, tool and motor loads the generator will power at one time. This total should not be greater than the wattage capacity of the generator. If an electrical device nameplate gives only volts and amps, multiply volts times amps to obtain watts (volts x amps = watts). Some electric motors require more amps of current for starting than for continuous operation.

1.3 SAFETY

Before using the generator set, carefully read GENERAL SAFETY RULES inside the cover. Comply with these RULES to prevent accidents and damage to equipment and/or property. Generac suggests copying and posting the GENERAL SAFETY RULES in potential hazard areas of the recreational vehicle. Safety should be stressed to all operators of this equipment.

1.4 GENERATOR CONTROL PANEL

Mounted on the generator control panel (Figure 1.1) are the following features:

Figure 1.1 — Typical Control Panel

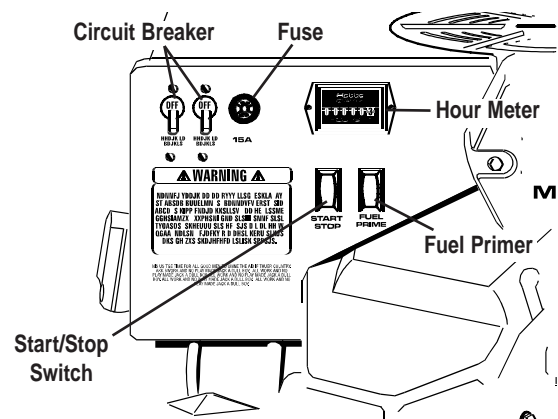

◆ 1.4.1 FUEL PRIMER

Before starting a cold engine (if it has not been started in more than two weeks), you must press this switch to bring fuel from the tank to the fuel carburetor. This rocker type switch springs back into its original position when you release it.

◆ 1.4.2 START/STOP SWITCH

To crank and start the engine, hold this switch at its START position. Release the switch when the engine starts. To stop an operating engine, press and hold the switch in its STOP position until the engine shuts off. The switch center position is the RUN position.

◆ 1.4.3 FUSE

Protects the engine DC control circuit against electrical overload. If the fuse element has melted open due to overloading, the engine cannot be cranked. If you must replace it, use only an identical replacement fuse.

◆ 1.4.4 CIRCUIT BREAKERS

Protects generator's AC output circuit against overload, i.e., prevents unit from exceeding wattage/ampere capacity.

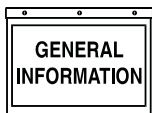

◆ 1.4.5 HOUR METER

Indicates the time the engine-generator has operated, in hours and tenths of hours. Use the hourmeter along with the periodic maintenance schedule for your generator set.

1.5 AUTOMATIC CHOKE (GASOLINE ONLY)

The engine is equipped with an automatic choke (not shown) that consists of two main components — choke solenoid and prechoke.

◆ 1.5.1 CHOKE SOLENOID (GASOLINE ONLY)

During engine cranking (start/stop switch at START), a solid state control circuit board signals the choke solenoid to actuate and cycle (choke on/choke off) until engine starts. The choke solenoid thus opens and closes the carburetor choke valve only when the engine is cranking. When the engine starts, the choke cycling stops.

◆ 1.5.2 PRECHOKE (GASOLINE ONLY)

The choke system also has a temperature sensitive metal strip that adjusts the choke valve angle according to ambient temperatures (i.e., in cold ambient temperatures the choke valve closes more). Once the engine starts, an element heats the temperature-sensitive strip to a normal operating condition, opening the choke valve. This may take about 3 minutes in cooler weather.

1.6 ENGINE PROTECTIVE DEVICES

This generator has a computer that monitors low oil pressure, oil temperature, engine speed, and low voltage output. This section discusses those protective devices.

◆ 1.6.1 AUTOMATIC LOW OIL PRESSURE SHUTDOWN

The engine is equipped with an oil pressure sensor that shuts down the engine automatically when oil pressure is too low. If the engine shuts down by itself and the fuel tank has enough fuel, check the engine oil level.

▶ 1.6.1.1 Initial Startup

During initial startup, a time delay built into the shutdown control system allows oil pressure to build. The delay allows the engine to run for about 10 seconds before sensing oil pressure.

▶ 1.6.1.2 Sensing low pressure

If the system senses low oil pressure during operation, the engine shuts down. If you do restart the engine after a low oil pressure shutdown and have not corrected the low oil level, the engine runs for about 10 seconds as described above then stops.

◆ 1.6.2 HIGH TEMPERATURE SHUTDOWN

A temperature switch with normally-open (N.O.) contacts is mounted near the oil filter. If engine temperature were to exceed a preset temperature, the switch contacts close and the engine shuts down.

◆ 1.6.3 OVERSPEED

If engine speed is increased manually (or otherwise) beyond the control of the computer control system, the computer disables the load capability of the generator and shuts down the engine.



 **Do not attempt to physically adjust or control the engine speed. Equipment damage or personal injury may result.**

◆ 1.6.4 LOW VOLTAGE

The computer monitors the voltage output of the generator. If voltage sensors indicate that voltage has dropped below a preset level, the engine will automatically shut down. Once the unit has shutdown, the computer is automatically reset when you restart the engine.

NOTE:

The computer allows for the low voltage output that occurs during startup. A time delay that allows the engine to start and warm up is programmed into the monitoring system.



 **Before restarting a generator that has been shutdown, disconnect all loads the generator might power by whatever means provided, such as the recreational vehicle's main circuit breaker.**

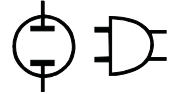

2.1 BEFORE STARTING THE ENGINE

IMPORTANT: INSTRUCTIONS AND INFORMATION IN THIS MANUAL ASSUME THE GENERATOR HAS BEEN PROPERLY INSTALLED, CONNECTED, SERVICED, TESTED AND ADJUSTED BY A QUALIFIED INSTALLATION TECHNICIAN OR INSTALLATION CONTRACTOR.

◆ 2.1.1 INSTALLATION

Generator installation must have been properly completed so it complies with all applicable codes, standards and regulations and with the manufacturer's recommendations.

◆ 2.1.2 ENGINE LUBRICATION

Have engine crankcase properly serviced with recommended oil before starting. Refer to "Maintenance" and "Specifications" sections for oil servicing procedures and recommendations.



Any attempt to crank or start the engine before you have properly serviced it with the recommended oil may result in engine failure.

◆ 2.1.3 FUEL SUPPLY

The engine must have adequate supply of proper fuel to operate. Before starting, check that sufficient fuel is available.

NOTE:

On some gasoline installations, the generator engine may "share" the vehicle's gasoline fuel tank with the vehicle engine. Some installations may provide separate fuel tanks for generator and vehicle engine.

◆ 2.1.4 COOLING AND VENTILATING AIR

Air inlet and outlet openings in the generator compartment must be open and unobstructed for continued proper operation. Without sufficient cooling and ventilating air flow, the engine-generator quickly overheats, which causes it to automatically shutdown. Overheating could also damage the unit or your vehicle.

◆ 2.1.5 ENGINE EXHAUST GAS

Before starting the generator engine, you should be sure there is no way for exhaust gases to enter the vehicle interior and endangering people or animals. Close windows, doors and other openings in the vehicle that, if open, might permit exhaust gases to enter the vehicle.



The generator engine gives off deadly carbon monoxide gas through its exhaust system. This dangerous gas, if breathed in sufficient concentrations, can cause unconsciousness or even death. Do not operate the generator if its exhaust system is leaking or has been damaged. Symptoms of carbon monoxide poisoning are (a) inability to think coherently, (b) vomiting, (c) twitching muscles, (d) throbbing temples, (e) dizziness, (f) headache, (g) weakness and sleepiness. If you feel any of these symptoms, move into fresh air immediately. If symptoms persist, get medical help.

2.2 STARTING THE GENERATOR

IMPORTANT: READ THE VEHICLE MANUFACTURER'S INSTRUCTIONS. THE OWNER/OPERATOR SHOULD BECOME FAMILIAR WITH THE VEHICLE IN WHICH THIS GENERATOR IS INSTALLED. DIFFERENCES EXIST BETWEEN VEHICLES. FOR EXAMPLE, SOME VEHICLES MAY USE A TRANSFER SWITCH TO ISOLATE DOCKSIDE POWER FROM THE GENERATOR, WHILE OTHER VEHICLES MAY USE AN ISOLATING RECEPTACLE. SOME VEHICLES MAY BE EQUIPPED WITH A DC CONVERTER WHICH ALLOWS THE GENERATOR TO POWER CERTAIN DC LIGHTING AND OTHER DC LOADS.

To crank and start the generator engine, proceed as follows:

1. Turn OFF electrical loads, using whatever means provided in your vehicle (such as a main line circuit breaker or transfer switch).

NOTE:

If you start the engine with the start/stop switch on the generator control panel, turn OFF loads by setting the panel's main breaker to its "OFF" or "OPEN" position. Electrical load circuits may be turned ON after the generator has started, stabilized and warmed up.

NOTE:

On gas units you only need to use the fuel primer during the initial startup, after the unit has not been used for an extended period of time (two weeks) or the fuel line has been disconnected. The primer is used to prime the fuel pump and carburetor.

2. To crank and start the engine, hold the start/stop switch at START. Release the switch when the engine starts.

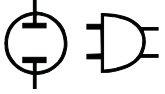

CAUTION



If the engine does not start after it has been cranking for 15 seconds, release the start/stop switch and try again. Holding the switch for longer than 15 seconds may damage the starter motor.

3. Let the engine run at no-load for a few minutes to stabilize and warm up the engine.
4. Turn ON electrical loads, using whatever means provided (such as a main circuit breaker or transfer switch).

NOTE:

If you start a warm generator engine, you may press the start switch only slightly to engage the ignition system. However, you should press and hold the starter switch for a minimum of two (2) seconds to energize the field boost system. If you start the engine without energizing the field boost system, the generator produces no output.

2.3 STOPPING THE GENERATOR

1. Turn OFF all electrical loads, using whatever means provided (such as a main circuit breaker or transfer switch).
2. Let the generator run at no-load for a few minutes, to stabilize internal engine-generator temperatures.
3. Hold Start/Stop switch in its STOP position.

2.4 APPLYING LOADS TO GENERATOR

When applying electrical loads to the generator, observe these guidelines:

- Before applying electrical loads, let the generator stabilize and warm up for a minute or two.
- DO NOT overload the generator.

◆ 2.4.1 LETTING ENGINE STABILIZE

The generator supplies correctly rated frequency and voltage only at the proper governed speed. Some electrical appliances may be extremely sensitive to voltage and frequency. Incorrect frequencies and/or voltages can damage those appliances.

If electrical loads are applied at reduced operating speeds, such loads imposed on the engine when sufficient power is not available may shorten engine life. Never turn ON electrical loads until after the generator engine has started and stabilized ON-speed.

2.5 ATTENTION REQUIRED AFTER SUBMERSION

If the motor home generator has been submerged in water, it must NOT be started or operated. Following any submersion in water, have an authorized Generac Service Facility thoroughly clean and dry the generator.

2.6 OPERATION IN HIGH GRASS OR BRUSH

Never operate the generator while the vehicle is parked in high grass, weeds, brush or leaves. Such materials can ignite and burn from the heat of the exhaust system. The generator exhaust system becomes extremely hot during operation and remains hot for a long time after it has shut down.

2.7 OPERATING PRECAUTIONS

Never operate the motor home generator set while the vehicle is parked over dry leaves, dry grass or any other combustible substance. The generator's exhaust system becomes extremely hot and can cause a fire if it is too close to combustible materials.

2.8 FUEL REQUIREMENTS (GASOLINE UNITS)

These generators are equipped with gasoline fuel systems as standard equipment. Specific installations may provide either a separate fuel tank for the generator, or the generator may "share" the vehicle engine's fuel tank.

NOTE:

Installations using a "shared" fuel tank may have a generator fuel pickup tube that is shorter than the vehicle engine's pickup tube. Such an arrangement causes the generator engine to "run out of gas" while adequate fuel for the vehicle remains in the tank.

To reduce lead and carbon deposits use high quality UNLEADED gasoline with the generator. Leaded REGULAR grade gasoline is an acceptable substitute.

NOTE:

Using "Unleaded" gasoline contributes to longer engine valve life by reducing lead and carbon deposits.

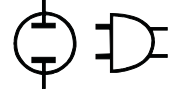

CAUTION

Generac does not recommend using any gasoline containing alcohol, it must not contain more than 10 percent ethanol and it must be removed from the generator during storage. Do NOT use any gasoline containing methanol. If you use gasoline with alcohol, inspect more frequently for fuel leaks and other abnormalities.

FUEL CONSUMPTION (IN GALLONS PER HOUR):

LOAD	GASOLINE	LP
NO	0.14	0.20
HALF	0.32	0.41
FULL	0.54	0.77

2.9 FUEL REQUIREMENTS (LP UNITS)

These generators are equipped with a liquefied petroleum (LP) gas fuel system. LP gas is usually supplied as a liquid in pressure tanks.

These generators require a “vapor withdrawal” type fuel system. This type of gaseous fuel system uses the vapors forming above the liquid fuel in the storage tank. Air temperature around the storage tank must be high enough to sustain adequate fuel vaporization. In colder climates, you may need to use an independent heat source to be sure the fuel sufficiently vaporizes in the storage tank.

LP gas may consist of propane, butane or a mixture of the two gases. Propane vaporizes at temperatures as low as -20°F (-29°C), but butane returns to its liquid state when the temperature drops below about 32°F (0°C). For that reason, a higher ratio of propane is desired in the gas mixture when temperatures drop below freezing.

2.10 ENGINE OIL REQUIREMENTS

The recommended oils include the following:

- During summer months: SAE 30. An acceptable substitute is SAE 10W-30.
- During winter months: SAE 5W30. DO NOT USE SAE 10W-40.

Crankcase and oil filter capacity is about 950ml or one (1) quart. Use no special additives. See “Maintenance” section for oil level check and fill procedures.

2.11 GAS GENERATOR SPECIFICATIONS

ModelImpact-36G plus II

Rated Maximum Continuous
AC Power Output3600 watts (3.6 kW)

Rated Voltage120 volts AC

Rated Maximum Continuous
Current at 120 volts30 AC amperes

PhaseSingle Phase

Rated AC Frequency60 Hz.

Recommended Battery
Cranking Current400 amps

Gross Weight.....97 lbs

Maximum Cranking Current.....250 Amps

Maximum Charging Current2 Amps

2.12 LP GENERATOR SPECIFICATIONS

ModelImpact-36LPG plus II

Rated Maximum Continuous
AC Power Output3400 watts (3.4 kW)

Rated Voltage120 volts AC

Rated Maximum Continuous
Current at 120 volts.....28.3 AC amperes

PhaseSingle Phase

Rated AC Frequency60 Hz.

Recommended Battery
Cranking Current400 amps

Gross Weight.....99 lbs

Maximum Cranking Current.....250 Amps

Maximum Charging Current2 Amps

2.13 ENGINE SPECIFICATIONS

Type of EngineGN-220

Cooling MethodAir-cooled

Displacement.....220cc

Type of GovernorElectronic

Air CleanerPaper element

Starter12 volt DC electric

Ignition SystemSolid state

Recommended Spark PlugsChampion RC12YC

Spark Plug Gap.....0.030 inch (0.8mm)

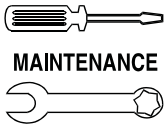

MAINTENANCE

Section 3 – Maintenance

IMPACT-36 plus II Recreational Vehicle Generator

3.1 MAINTENANCE

This section includes information about simple maintenance which includes the following tasks:

- Checking engine oil level.
- Changing engine oil.
- Changing oil filter.
- Air cleaner maintenance.
- Cleaning the air intake screen.
- Cleaning spark arrestor.
- Cleaning spark plug.
- Replacing fuel filter.
- Servicing inverter.

3.2 CHECKING ENGINE OIL LEVEL

Check engine crankcase oil level at least every eight hours of operation, or before each use (Figure 3.1).

- Be sure the generator is as level as possible.
- Remove oil dipstick and wipe dry with clean, lint-free cloth.
- Install and tighten oil dipstick, then remove again.
- Oil should be at dipstick FULL mark. If necessary, add the recommended oil to the FULL mark only. DO NOT FILL ABOVE “FULL” MARK.
- Install and tighten oil dipstick cap before operating the engine.

Figure 3.1 — Oil Dipstick and Fill Tube

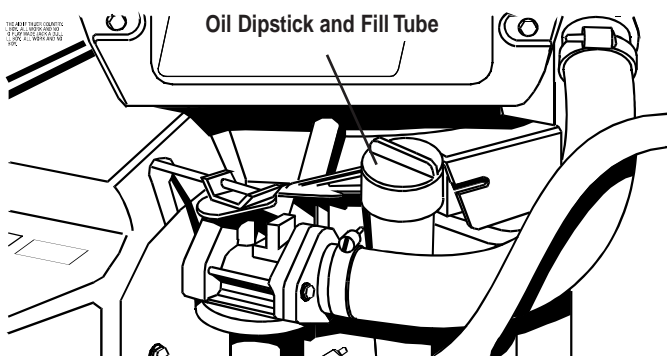

NOTE:

See “Engine Oil Requirements” on Page 11 for recommended oils.

3.3 CHANGE ENGINE OIL

Change engine oil after the first 8 hours of operation. Thereafter, change oil every 100 operating hours. Change oil more frequently if operating consistently under heavy load or at high ambient temperatures.

- Warm up engine for at least five minutes, then shut down.
- With engine still warm from running, clean area around oil drain plug and remove oil drain plug (Figure 3.2). Drain oil completely into a suitable container.
- When oil has drained, install and tighten drain plug.
- Remove oil dipstick and fill crankcase with the recommended oil (See Page 11). The engine crankcase can hold about 1 quart (950ml). DO NOT FILL ABOVE “FULL” MARK.
- Install and tighten dipstick cap before operating engine.

3.4 CHANGE OIL FILTER

Replace the engine oil filter after the first 8 hours of operation, every 100 operating hours thereafter.

- Turn oil filter counterclockwise to remove (Figure 3.2).

Figure 3.2 — Oil Drain Plug and Engine Oil Filter

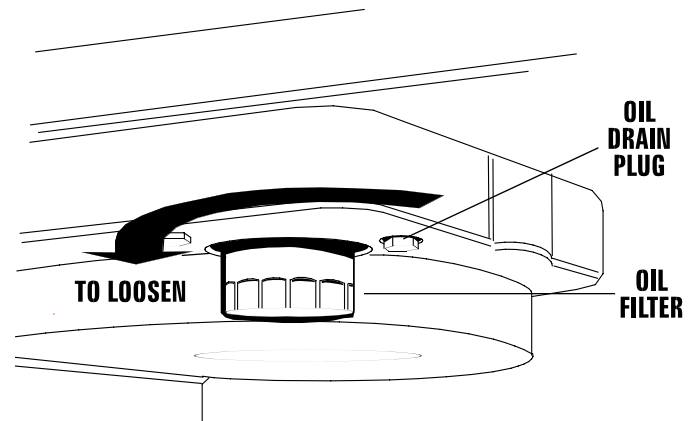

- Coat gasket of new filter with engine oil.
- Turn new filter clockwise until its gasket contacts lightly with the filter adapter. Then tighten an additional 3/4 to one turn by hand.
- Run engine and check for leaks.

NOTE:

Check oil level and fill to full mark after checking for leaks. Filter will retain some oil.

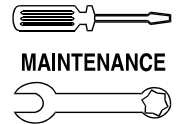

3.5 ENGINE AIR CLEANER

Paper Filter: Once every 25 operating hours or once each year (whichever comes first), clean or replace the paper filter (Figure 3.3). Follow the steps on page 12.

Figure 3.3 — Engine Air Cleaner Assembly

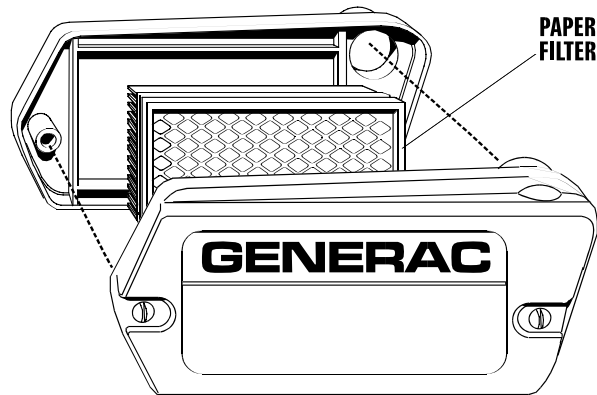

- Remove air cleaner cover, then remove paper filter.
- Clean air filter by gently tapping it on a solid surface. If the filter is too dirty, replace it with a new one. Dispose of the old filter properly.
- Clean air cleaner cover then insert new paper filter into cover and assemble to the base of the air cleaner.

3.6 CLEAN AIR INTAKE SCREEN

Clean all foreign material from the air intake screen (Figure 3.4) at least once every 100 hours of operation. Clean more often if necessary.

Inspect the area around the generator exhaust muffler periodically and remove all grass, leaves, dirt, etc. from this area.

Figure 3.4 — Clean Air Intake Screen

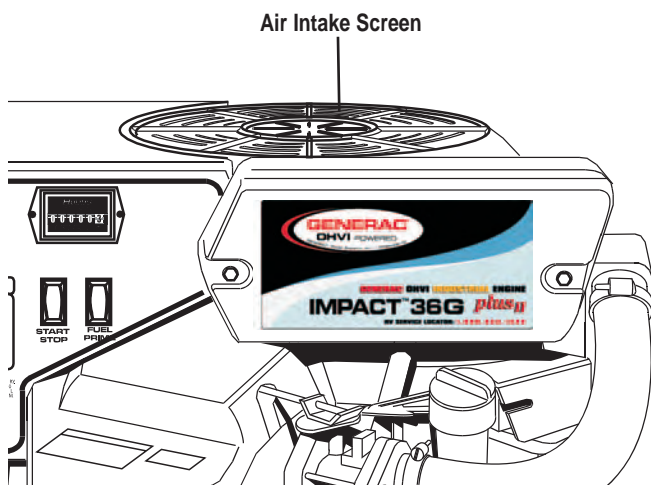

3.7 ENGINE SPARK PLUG

Clean engine spark plug and set gap to 0.030 inch (0.76mm) every 100 hours of operation (Figure 3.5). Clean by scraping or wire brushing and washing with commercial solvent. DO NOT BLAST CLEAN SPARK PLUG.

Figure 3.5 — Setting Gap on Spark Plug

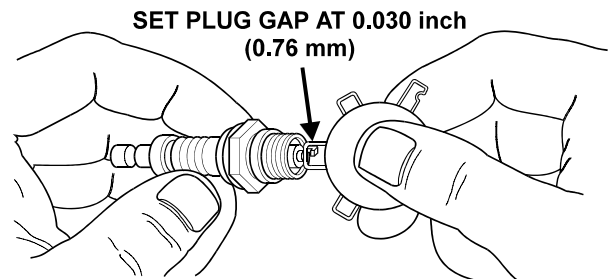

CAUTION

Sparking can occur if wire terminal does not fit firmly over spark plug terminal end. If necessary, reform wire terminal to obtain a tight fit.

3.8 FUEL FILTER

Remove and replace fuel filter (Figure 3.6) every 100 hours of operation or once each year, whichever occurs first.

Figure 3.6 — Fuel Filter

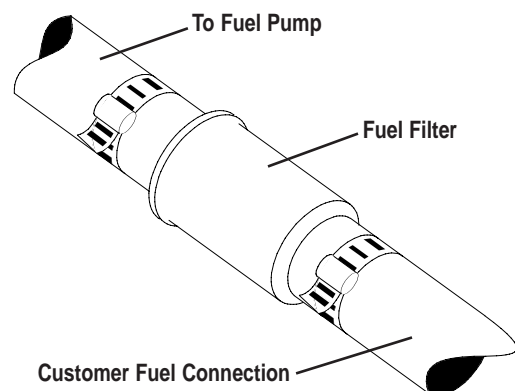

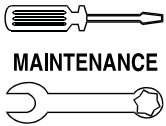

3.9 INVERTER

All repairs of the inverter must be handled by an authorized service dealer (see Figure 3.7).

Figure 3.7 — Inverter Warning Label

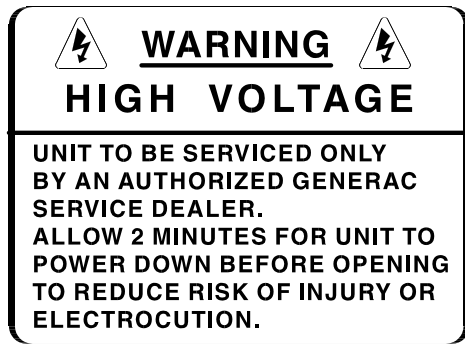

3.10 CLEANING THE GENERATOR

Keep your generator set as clean and dry as possible. Dirt and moisture that are permitted to accumulate on electrical windings have an adverse affect on the insulation resistance of those windings.

Moisture that is allowed to remain in contact with windings will be retained in voids and cracks of the windings. Dirt makes the problem worse, since it tends to hold the moisture into contact with the windings. Salt, as from sea air, worsens the problem since it tends to absorb moisture from the air. The combination of salt and moisture makes a good electrical conductor.



CAUTION



Do NOT use a forceful spray of water to clean the generator. Water will enter the generator interior and cause problems, and may also contaminate the generator fuel system.

3.11 BATTERY

All lead-acid storage batteries will discharge when not in use. Inspect the generator battery as follows:

◆ 3.11.1 ONCE WEEKLY

Inspect battery posts and cables for tightness, corrosion. Clean and/or tighten as necessary.

Also check battery fluid level, and, if necessary, fill with DISTILLED WATER ONLY. DO NOT USE TAP WATER IN BATTERY.

◆ 3.11.2 EVERY SIX MONTHS

Have the battery state of charge and condition checked by an automotive service facility. This should be done with an automotive type battery hydrometer.



Storage batteries give off explosive hydrogen gas. This can form an explosive mixture around the battery for several hours after charging. The slightest spark can ignite the gas and cause an explosion. Such an explosion can shatter the battery and cause blindness or other injury. Any area that houses a storage battery must be properly ventilated. Do not allow smoking, open flame, sparks or any spark producing tools or equipment near the battery.



Battery electrolyte fluid is an extremely caustic sulfuric acid solution that can cause severe burns. Do not permit fluid to contact eyes, skin, clothing, painted surfaces, etc. Wear protective goggles, protective clothing and gloves when handling a battery. If you spill the fluid, flush the affected area immediately with clear water.



Do not use any jumper cables or booster battery to crank and start the generator engine. If any battery has discharged, remove it from the vehicle for recharging.

3.12 SERVICE AND ADJUSTMENTS

◆ 3.12.1 ENGINE SPEED

Engine speed is completely computer-controlled. There is no adjustment for speed on the unit. The computer adjusts the engine speed using an electronic governor throttle control. The computer monitors the demand for power and adjusts the engine speed accordingly. This allows the engine to produce only the power required, resulting in fuel economy as well as lowering the overall noise emitted.

NOTE:

The computer will disable the electrical load capabilities of the generator and enter a fault condition if you accelerate the throttle manually or any other way.

3.13 ADJUSTING THE CARBURETOR

The carburetor of your generator is preset at the factory. The carburetor should not be tampered with, as this will void the emission control system warranty. If your generator is used at altitudes in excess of 5,000 feet, consult your Generac Authorized Service Facility regarding high altitude jetting changes.

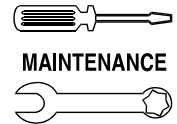

3.14 ADJUSTING VALVE CLEARANCE

After the first 50 hours of operation, you should adjust the valve clearance in the engine.

When adjusting valve clearance, the engine should be at room temperature and the piston should be at Top Dead Center (TDC) of its compression stroke (both valves closed). Correct clearance is 0.001-0.003 inch (0.03-0.07mm). Adjust valve clearance as follows:

1. Loosen the rocker arm jam nut. Use an allen wrench to turn the pivot ball stud while checking clearance between the rocker arm and the valve stem with a feeler gauge (Figure 3.8).

Figure 3.8 — Adjusting Valve Clearance

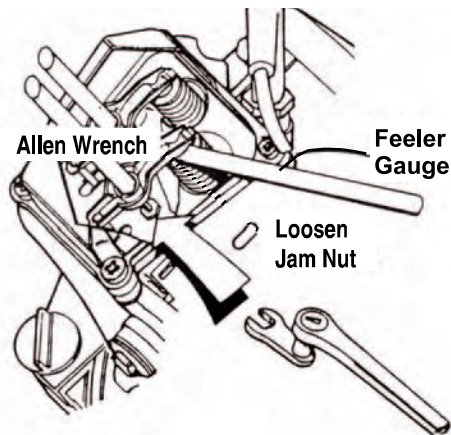

2. When valve clearance is correct, hold the pivot ball stud with the allen wrench and tighten the rocker arm jam nut with a crow's foot. Tighten the jam nut to 65-85 inch-pounds torque. After tightening the jam nut, recheck valve clearance to make sure it did not change (Figure 3.9).

Figure 3.9 — Tightening Jam Nut

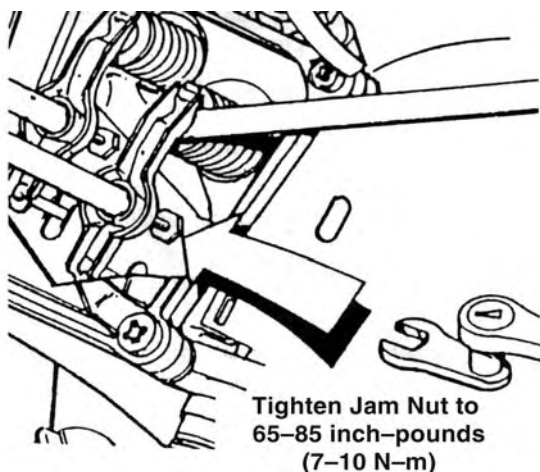

3.15 MAJOR SERVICE MANUAL

To obtain a service manual for your generator, order it from your dealer/distributor or contact the factory. Be sure to identify your unit's MODEL NUMBER and SERIAL NUMBER.

3.16 EXERCISING THE GENERATOR

Generac recommends that you start and operate the generator at least once every seven days. Let the unit run for at least 30 minutes to "exercise" the engine.

3.17 OUT OF SERVICE PROTECTION

If you cannot exercise the generator every seven days and it is to be out of service longer than 30 days, prepare the generator for storage as follows:

- Start the engine and let it warm up.
- While the engine is still warm from running, drain the oil completely. Refill crankcase with recommended oil. See "Specifications."
- Attach a tag to the engine indicating the viscosity and classification of the oil in the crankcase.
- Remove spark plug and add about 1/2 ounce (15ml) of clean, fresh engine oil into spark plug threaded opening. Crank engine several times to distribute oil, then install and tighten spark plug.
- Remove the battery and store in a cool, dry room on a wooden board. Never store the battery on any concrete or earthen floor.
- Clean and wipe the entire generator.

3.18 RETURN UNIT TO SERVICE AFTER STORAGE

To return the unit to service after storage, proceed as follows:

- Check tag on engine for oil viscosity and classification. Verify that the correct recommended oil is used in engine. If necessary, drain and refill with proper oil.
- Check battery. Fill all cells to the proper level with distilled water. DO NOT USE TAP WATER IN THE BATTERY. Recharge battery to 100% state of charge, or, if defective, replace the battery.
- Turn OFF all electrical loads, then start the engine.
- Let engine warm up.
- Apply electrical loads up to at least 50% of the unit's rated wattage capacity.
- When engine is thoroughly warmed up, shut it down.

THE GENERATOR IS NOW READY FOR SERVICE.

PART II – INSTALLATION INSTRUCTIONS

—▲ **DANGER** ▲—

**ONLY QUALIFIED ELECTRICIANS OR CONTRACTORS
SHOULD ATTEMPT INSTALLATION!!**



⚠ DANGER: For fire safety, installation of a generator into a recreational vehicle must comply strictly with NFPA 70 (latest edition), “National Electrical Code”, Article 551, and NFPA 1192 (latest edition), “Standard for Recreational Vehicles”. In addition, installation must comply with the manufacturer’s instructions and recommendations. **⚠**

NOTICE TO INSTALLER

These *Installation Instructions* have been published by Generac to aid in the installation of the products described in this manual. Generac assumes that installation personnel are familiar with the procedures for installing such products, or similar products that Generac manufactures. Generac also assumes that personnel have been trained in the recommended installation procedures for these products and that such training includes (a) use of common hand tools, (b) use of special Generac tools, and (c) use of any tools and/or equipment from other suppliers.

Generac cannot possibly know of, nor advise the recreational vehicle trade of, all conceivable methods, procedures, or techniques by which to perform an installation. Nor can Generac anticipate every possible hazard that might result from each installation method, procedure, or technique. Generac has not undertaken any such wide evaluation. Therefore, people who use a method, procedure, or technique that Generac does not specifically recommend must first completely satisfy themselves that their safety, the safety of the vehicle's occupants, and the product's safety are not endangered by the method, procedure, or technique selected.

Information, illustrations, specifications, etc., contained in these *Installation Instructions* are based on the latest information available at the time of publication. Every effort has been expended to be sure that such data are both accurate and current. However, the manufacturer reserves the right to change, alter, or otherwise improve this product at any time, without prior notice.

— **⚠ DANGER** ⚠ —

⚠ Despite the safe design of this generator, operating this equipment imprudently, neglecting its maintenance, or being careless can cause possible injury or death. Permit only responsible and capable persons to operate or maintain this equipment.

⚠ Parts of the generator are rotating and/or hot during operation. Exercise care near running generators.

⚠ Potentially lethal voltages are generated by these machines. Ensure all steps are taken to render the machine safe before attempting to work on the generator.

⚠ GENERAL HAZARDS ⚠

- For safety reasons, Generac recommends that the installation, initial startup, and maintenance of this equipment is carried out by a Generac Authorized Service Dealer.
- The engine exhaust fumes contain carbon monoxide, which can be DEADLY. This dangerous gas, if breathed in sufficient concentrations, can cause unconsciousness or even death. This exhaust system must be installed properly, in strict compliance with applicable codes and standards. Following installation, you must do nothing that might render the system unsafe or in noncompliance with such codes and standards. The generator compartment must be completely vapor-sealed from the vehicle interior. There must be no possibility of exhaust fumes entering the vehicle interior. Never operate this equipment with a leaking or defective exhaust system.
- Keep hands, feet, clothing, etc., away from drive belts, fans, and other moving or hot parts. Never remove any drive belt or fan guard while the unit is operating.
- Adequate, unobstructed flow of cooling and ventilating air is critical to correct generator operation and is required to expel toxic fumes and fuel vapors from the generator compartment. Without sufficient cooling airflow, the engine/generator quickly overheats, which causes serious damage to the generator. Do not alter the installation or permit even partial blockage of ventilation provisions, as this can seriously affect safe operation of the generator.
- When working on this equipment, remain alert at all times. Never work on the equipment when you are physically or mentally fatigued.
- Before performing any maintenance on the generator, disconnect its battery cables to prevent accidental startup. First, disconnect the cable from the battery post, indicated by a NEGATIVE, NEG, or (-). Reconnect that cable last.
- Never use the generator or any of its parts as a step. Stepping on the unit can stress and break parts, and may result in dangerous operating conditions from leaking exhaust gases, fuel leakage, oil leakage, etc.
- Never insert any tool or other object through openings in the generator interior, even if the unit is not running. You might seriously injure yourself or damage the equipment.



ELECTRICAL HAZARDS

- The generator covered by this manual produces dangerous electrical voltages that can cause fatal electrical shock. Avoid contact with bare wires, terminals, connections, etc., while the unit is running. Ensure all appropriate covers, guards, and barriers are in place before operating the generator. If you must work around an operating unit, stand on an insulated, dry surface to reduce shock hazard.
- Do not handle any kind of electrical device while standing in water, while barefoot, or while hands or feet are wet. **DANGEROUS ELECTRICAL SHOCK MAY RESULT.**
- During installation onto the vehicle, properly ground (bond) the generator either by solid mounting to the vehicle frame or chassis, or by means of an approved bonding conductor. **DO NOT** connect the bonding conductor to any generator part that might be removed or disassembled during routine maintenance. If the grounding conductor must be replaced, use only a flexible conductor that is of No. 8 American Wire Gauge (AWG) copper wire minimum.
- If the vehicle electrical circuits can be powered by any other source of electricity (such as, a “dockside” power receptacle), there must be no possibility of connecting the different power sources to the vehicle’s circuits at the same time. The dockside (utility) power source must be positively isolated from the vehicle’s circuits whenever the generator is operating. Failure to isolate the vehicle’s circuits from the dockside power supply when the generator is running may result in damage to the generator or in serious injury or death to dockside (utility) power workers due to backfeed of electrical energy.
- In case of an accident caused by electric shock, immediately shut down the source of electrical power. If this is not possible, attempt to free the victim from the live conductor. **AVOID DIRECT CONTACT WITH THE VICTIM.** Use a nonconducting implement, such as, a rope or board, to free the victim from the live conductor. If the victim is unconscious, apply first aid, and get immediate medical help.
- Never wear jewelry when working on this equipment. Jewelry can conduct electricity, resulting in electric shock, or may get caught in moving components, causing injury.

FIRE HAZARDS

- For fire safety, the generator must be installed and maintained properly. Installation always must comply with applicable codes, standards, laws, and regulations. Adhere strictly to local, state and national electrical and building codes. Comply with regulations the Occupational Safety and Health Administration (OSHA) has established. Also, ensure that the generator is installed in accordance with the manufacturer’s instructions and recommendations. Following proper installation, do nothing that might alter a safe installation and render the unit in noncompliance with the aforementioned codes, standards, laws, and regulations.
- Keep a fire extinguisher in the vehicle at all times. Extinguishers rated “ABC” by the National Fire Protection Association are appropriate for use on the recreational vehicle generator electrical system. Keep the extinguisher properly charged, and be familiar with its use. If you have any question pertaining to fire extinguishers, consult your local fire department.

EXPLOSION HAZARDS

- Do not smoke around the generator. Wipe up any fuel or oil spills immediately. Ensure that no combustible materials are left in the generator compartment, or on or near the generator, as **FIRE** or **EXPLOSION** may result. Keep the area surrounding the generator clean and free from debris.
- All fuel types are potentially **FLAMMABLE** and/or **EXPLOSIVE** and should be handled with care. Comply with all laws regulating the storage and handling of fuels.
- Fuel supply lines must be properly installed, purged and leak-tested according to applicable fuel-gas codes, before placing this equipment into service. There must be no possibility of fuel vapors entering the vehicle interior.
- You are required to install an approved, flexible, nonconductive fuel line between the generator fuel connection point and the rigid fuel lines.

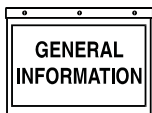

1.1 PURPOSE AND SCOPE OF THE MANUAL

These *Installation Instructions* have been prepared especially for the purpose of familiarizing installers and owners of the applicable equipment with the product's installation requirements. Give serious consideration to all information and instructions in the manual, both for safety and for continued reliable operation of the equipment.

Because of the different recreational vehicle models and the variations between the models, it would be extremely difficult, if not impractical, to provide detailed instructions for every possible installation. For that reason, instructions and illustrations in this manual are general in nature. Illustrations are not intended to serve as detailed installation blueprints.

The installation should comply strictly with all applicable codes, standards, and regulations pertaining to the installation and use of this product. If any portion of this manual appears to be in conflict with such codes, standards, or regulations, the applicable codes, standards, or regulations must take precedence over the manual.

1.2 SAFETY

Before handling, installing, operating, or servicing this equipment, carefully read the "Notice to Installer" and "Safety Rules" on Pages 18 and 19. Comply with all safety rules to prevent death, personal injury, or damage to equipment and/or property. Stress safety to all installers, operators, and service technicians who work on this equipment.

1.3 STANDARDS BOOKLETS

Installation, use, and servicing of this equipment should comply strictly with published standards, as well as the manufacturer's recommendations. The following standards booklets (latest revision) are available from the sources indicated:

1. NFPA 1192, "Standard for Recreational Vehicles" (replaces ANSI A119.2/NFPA 501C), available from the National Fire Protection Association, Batterymarch Park, Quincy, MA 02269.
2. NFPA 70, "NFPA Handbook of the National Electric Code," available same as Item 1.
3. ANSI/RVIA EGS-1, "Engine Generator Sets for Recreational Vehicle Safety Requirements", available from the Recreational Vehicle Industry Association, 1896 Preston White Drive, Reston, VA 22090.
4. California Administrative Code, Title 25, available from the State of California, Documents Section, P.O. Box 1015, North Highlands, CA 95660.
5. CSA Electrical Bulletin 946, available from the Canadian Standards Association, Housing and Constructions Materials Section, 178 Rexdale Boulevard, Rexdale, Ontario, Canada, M9W 1R3.

1.4 EQUIPMENT DESCRIPTION

Instructions and information in this section pertain to Generac Impact air-cooled generators — more specifically, the installation of Impact-34 plus II and IMPACT-36 plus II Recreational Vehicle Generators. These generators are designed specifically for installing in recreational vehicles.

1.5 ENGINE GENERATOR OPERATING SPEED

The generators are driven by gasoline-powered, single-cylinder engines. The engines drive revolving fields (rotors), high frequency, permanent magnet alternators. The generators supply 120 volts AC at 60 Hertz with DC inverter. The generators revolving fields are driven at a variable speed depending on the demand for power. Computers monitor that demand and adjust the engine speed to provide adequate power to the connected loads.

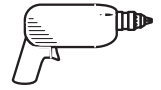

2.1 LOCATION AND SUPPORT

◆ 2.1.1 GENERATOR LOCATION

The most desirable location for the generator set is between the vehicle's main frame members. However, this is seldom possible. Most units must be installed on the side of the vehicle and are difficult to reinforce.

Many recreational vehicles have been factory equipped with an area for the generator set. Some vehicles may even have a generator compartment, provided by the vehicle manufacturer.

Plan the generator location based on the following:

- The generator set must be installed on a framework that is part of the recreational vehicle, as outlined in the paragraph entitled "Generator Support."
- The location must provide an access opening that is large enough to permit generator removal (unless the generator is to be removed from underneath the supporting framework).
- The location must provide easy access to frequently serviced components, such as filters, oil drains, spark plugs and other common maintenance parts.
- The location must provide sufficient room to allow minimum clearance of at least 1 inch between all sides and 1-1/2 inches on top of the generator. If sound insulation is to be used on compartment walls and ceiling, the minimum recommended applies to the space between the generator and such insulation.
- The location must provide adequate cooling and ventilating air flow for the generator without a great deal of work and expense.

◆ 2.1.2 GENERATOR SUPPORT

The generator must be securely attached to a metal framework that has been made part of the vehicle frame structure by bolting or welding. The metal framework on which the generator will rest and which will restrain the generator set should consist of at least two horizontal beams. These beams should consist of (a) 1-1/2 inch square, 11 gauge steel tubing OR (b) 1-1/2 inch, 11 gauge angle iron. A typical supporting frame with horizontal support tubing, is shown in Figure 2.1.

The generator can be installed so that it sits on top of the horizontal support tubing, if the vehicle design permits. Another method is to suspend the generator below the horizontal support tubing by means of suitable, structurally sound metal framework. The following general rules apply:

- Vehicle construction MUST be capable of supporting the weight of the generator.
- Whether the generator is mounted above the horizontal support tubing or suspended below the tubing, the supporting frame used must be structurally sound.

- If the generator cannot be bolted directly to the supporting frame or support tubing, consider using additional tubing, angle brackets or other supports to give the supporting frame sufficient strength.

Figure 2.1 — Typical Horizontal Support Frame

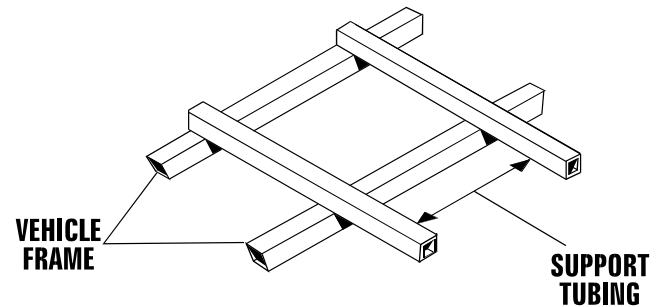

◆ 2.1.3 SUSPENDED MOUNTING

If you are going to suspend the generator below the horizontal support tubing, the suspension method you use with the vehicle frame members must have the following: (a) be able to support the weight of the generator; and (b) provide sufficient restraint for the generator. One typical suspended mounting system is shown in Figure 2.2. The location of a suspended mounting system must be carefully planned, keeping the following general rules in mind:

- Protect the generator against road splash and debris. Baffles or splash guards may be required to protect certain areas of the generator. To make sure the generator is adequately protected, road test the installation through mud, water and slush.

Figure 2.2 — Typical Suspended Mounting System

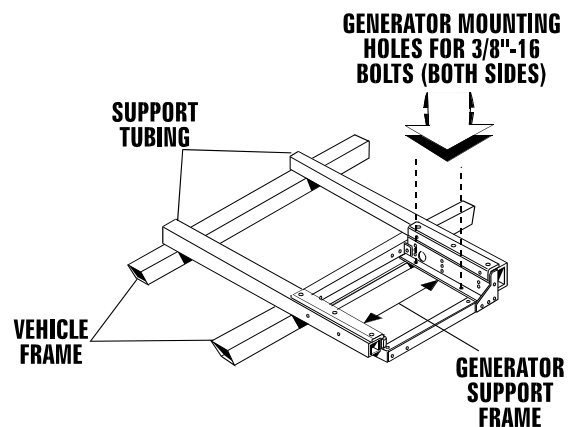

- The installer must make certain that selected location will permit adequate cooling and ventilating air flow to be supplied.

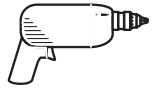

◆ 2.1.4 GENERATOR RESTRAINT

Use four 3/8"-16 hardened steel bolts (Grade 5) to fasten the generator to the supporting frame or the support tubing. These bolts must pass through (a) the generator mounting base, (b) the compartment floor, if a compartment is used, and (c) the supporting framework (Figure 2.3). All bolts must be long enough so that when tight, at least 3 threads are visible past the retaining lock nuts. Refer to "COMPARTMENT" section for location of generator mounting holes.

Figure 2.3 — Typical Generator Restraint

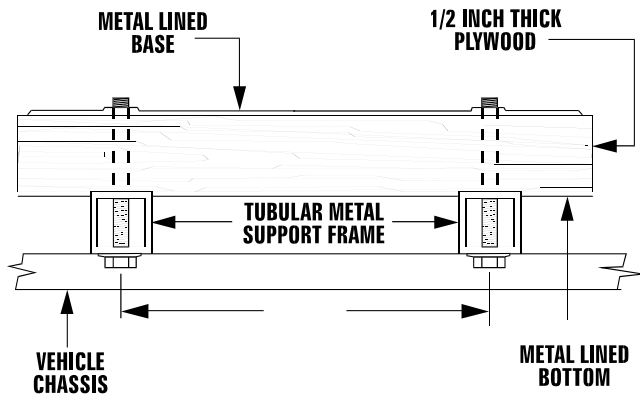

2.2 GENERATOR COMPARTMENTS

The generator set may or may not be installed inside a compartment that is constructed specifically for housing a generator. This section applies to generator compartments when they are installed. The following general rules apply to compartments:

- The generator compartment should be either constructed of, or lined with, 26 gauge galvanized steel.

IMPORTANT: ALUMINUM IS NOT AN ACCEPTABLE ALTERNATIVE TO GALVANIZED STEEL, DUE TO ALUMINUM'S LOW MELTING POINT.

- If the compartment is lined with galvanized steel, it may be constructed of any material. Generac recommends that the compartment be constructed of 1/2-inch thick plywood, with the floor made of a double thickness of plywood for added strength.
- All seams, splices and joints of the compartment walls (unless vapor tight by design) should be caulked.

IMPORTANT: CAULKING MUST BE DONE SO THAT THE CAULKING MATERIAL WILL STAY IN PLACE PERMANENTLY. PRESSING SUCH MATERIALS AS PUTTY TAPE ONTO JOINTS AND SEAMS WILL NOT MEET THAT REQUIREMENT. A HIGH QUALITY SILICONE RUBBER SEALANT IS RECOMMENDED.

- Holes and openings through the compartment walls for passage of electrical conduit, conductors, etc. into vehicle living area must be sealed vapor-tight with silicone rubber base sealant.
- If you use flexible metal conduit, seal the conduit at the end where it terminates inside the junction box. Flexible metal conduit is NOT vapor tight along its entire length.
- Seams and joints of the galvanized steel (whether used as a liner or the compartment itself) must be lapped and mechanically secured. Such seams may be manufactured, welded, bolted, riveted, or screwed. Manufactured lock seams are shown in Figure 2.4.

Figure 2.4 — Types of Lock Seams

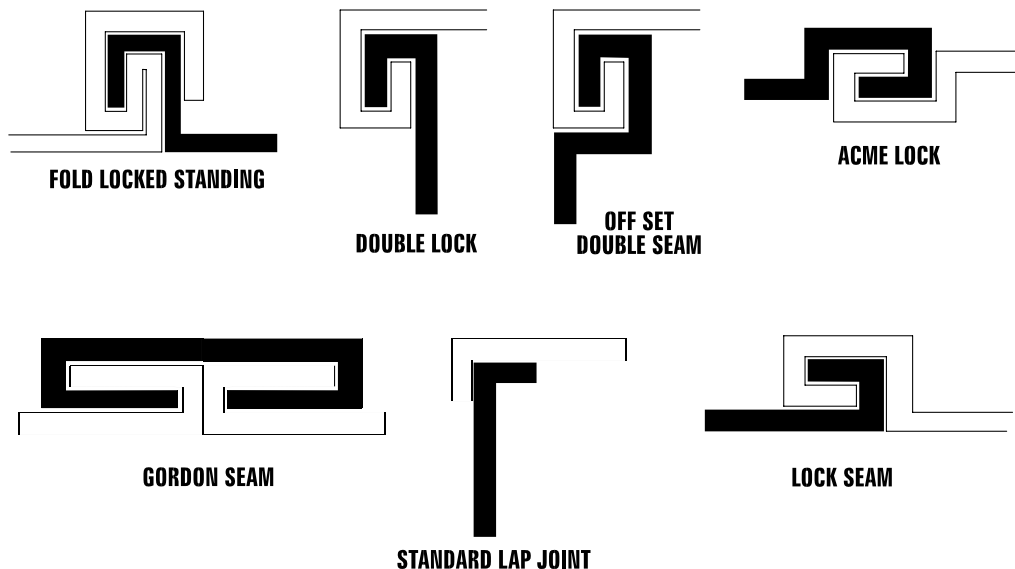

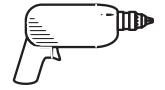

◆ 2.2.1 COMPARTMENT SIZE

Plan the compartment size carefully. Provide a minimum of at least 1 inch (2" recommended) of clearance between the generator and compartment walls and 1 inch (2" recommended) of clearance between the generator and the ceiling AFTER you have lined the compartment with metal, and AFTER you have installed sound insulation (Figure 2.5).

NOTE:

Refer to the "Major Features and Dimensions" drawing in the back of this manual.

Figure 2.5 — Provide Clearance Around Generator

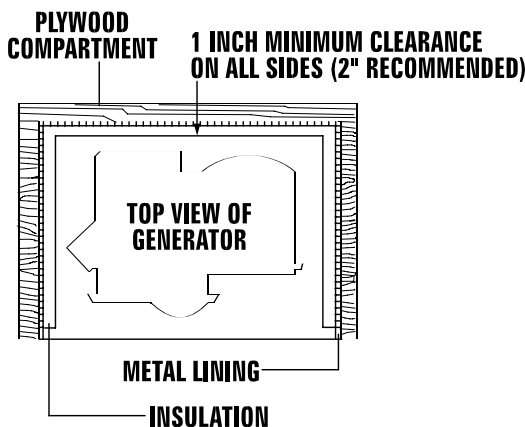

◆ 2.2.2 COMPARTMENT CONSTRUCTION

- The generator compartment should be constructed of 1/2 inch thick plywood. Make the compartment floor a double thickness of 1/2 inch plywood with the grain of the wood at cross section for added strength (Figure 2.6).

Figure 2.6 — Typical Compartment Construction

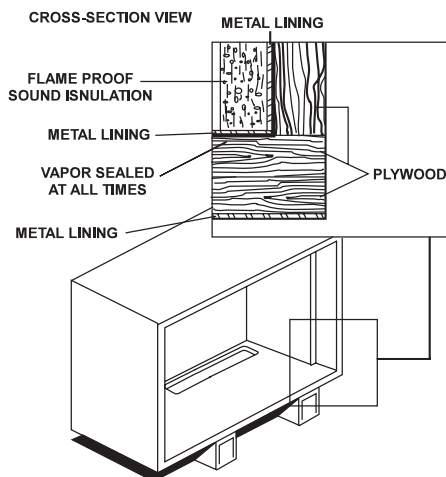

- Line the entire compartment interior with 26 gauge galvanized steel as described above.
- Line the exterior (underside) of the compartment floor with 26 gauge galvanized steel.
- Vapor seal all compartment seams and joints, to prevent poisonous, flammable or explosive vapors from entering the vehicle interior. Refer to the sealant information as noted previously.

NOTE:

Silicone rubber base sealant is an acceptable caulking material. Pressing putty tape onto compartment joints and seams is NOT acceptable.

- After the compartment has been metal lined and vapor sealed, line the compartment interior walls and ceiling with an approved, non-flammable sound insulating material. See "Sound Insulating Materials."



Do not install sound insulation or any absorbent material on the compartment floor interior. Such materials will become soaked with combustible or explosive vapors and liquids and will become a fire hazard.

- Openings in compartment walls for passage of electrical conduit, conductors, hoses, cables, etc., must be made vapor tight with suitable caulking material.
- Flexible conduit must be sealed internally at the end where it terminates inside a compartment's electrical junction box.

NOTE:

The preceding is required because flexible conduit, due to its unique construction, is not vapor-tight along its entire length.



Do not install any flammable material directly above or around the compartment. Heat, transferred through the compartment structure, may be sufficient to ignite, char or discolor seat cushions, fiberboard and other flammable materials. You may need to use approved non-flammable insulating materials in high temperature areas.

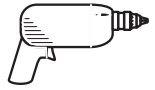

◆ 2.2.3 SOUND INSULATING MATERIALS

Once installers have determined that compartments are properly constructed and metal lined, they can add acoustical material. This may include additional sealant or insulating material, to reflect noise away from the vehicle interior.

Sound insulating materials should be of a non-flammable type. One excellent insulating material is a 1 inch thick fiberglass having a 2-pound density. When fiberglass is used, its coated side should face toward the compartment interior.

Using a combination of sound insulating materials can often reduce noise more effectively than a single material. For example, a sheet of lead or visco-elastic material, along with a layer of other acoustical material, is more effective than when a single material is used.

◆ 2.2.4 COMPARTMENT FLOOR CUTOUTS

You must provide openings in the generator compartment for the following items (Figure 2.7):

- Engine exhaust and cooling air outlets
- Generator cooling air inlet
- Four holes for passage of generator mounting bolts. See “Generator Restraint” on Page 19.



Fuel lines and exhaust piping must not penetrate into vehicle living area.

Figure 2.7 – Compartment Floor Cutout

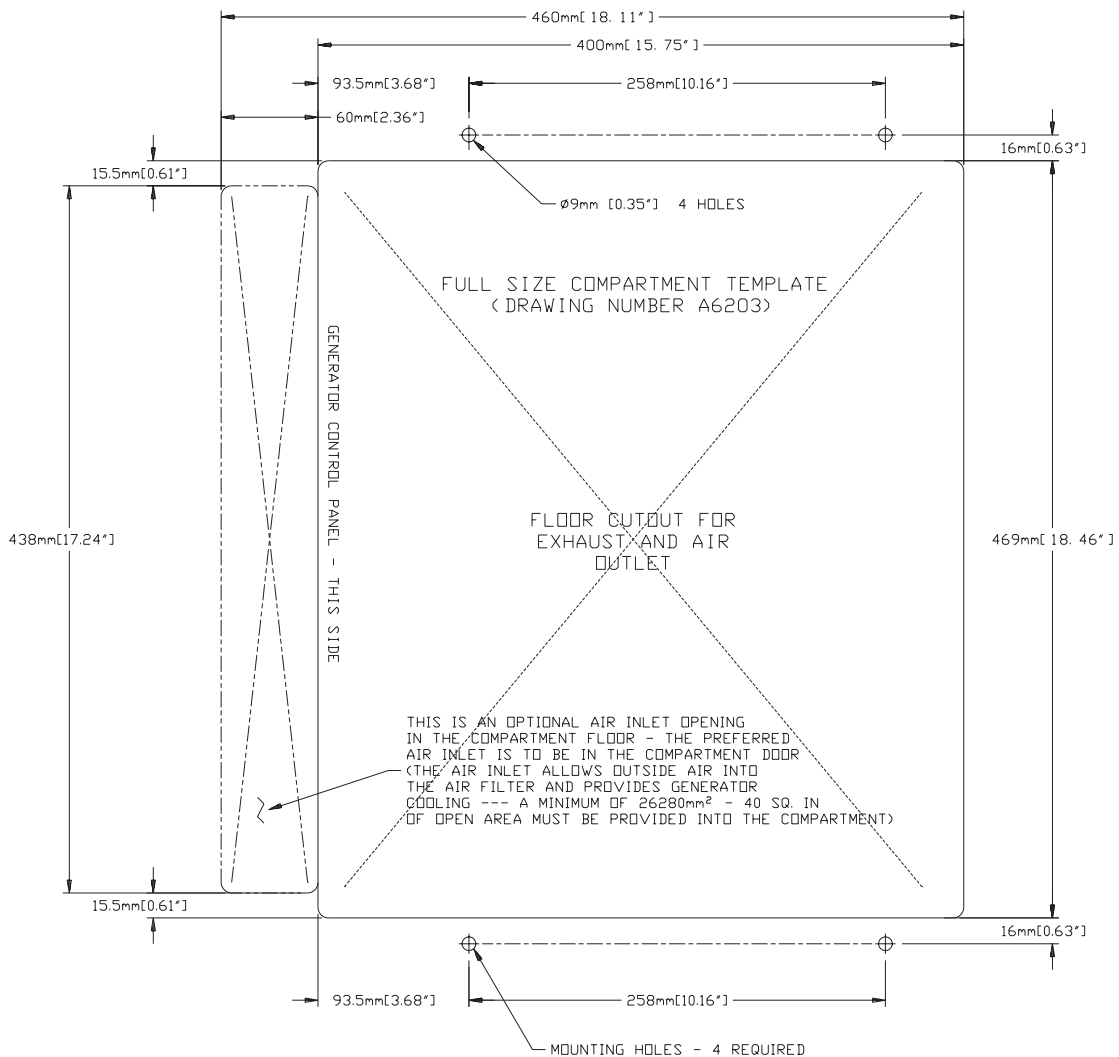

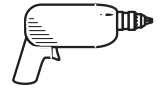

◆ 2.2.5 ACOUSTICS

If excessive noise levels should become a problem, the installer may wish to consider the following:

- Using special sound insulating materials.
- Construction of a special noise abatement compartment.

IMPORTANT: ANY METHOD USED TO REDUCE NOISE MUST NOT ADVERSELY AFFECT THE FLOW OF COOLING AND VENTILATING AIR INTO OR OUT OF THE COMPARTMENT.

In addition to the effective use of sound insulating materials, construction of a special noise abatement compartment might be considered to reduce noise levels. Such a compartment might be constructed as follows (Figure 2.8):

- Use 5/8-inch thick or 3/4-inch thick plywood in the compartment.
- Construct the compartment floor of a double thickness of 5/8-inch or 3/4-inch plywood.
- Line the compartment interior walls and floor, as well as the underside of the floor, with 26-gauge galvanized steel.
- Vapor seal all compartment seams and joints.
- Over the galvanized steel lining, install a selected combination of acoustical materials as mentioned in “Sound Insulating Materials.”

Figure 2.8 — Typical Noise Abatement Compartment

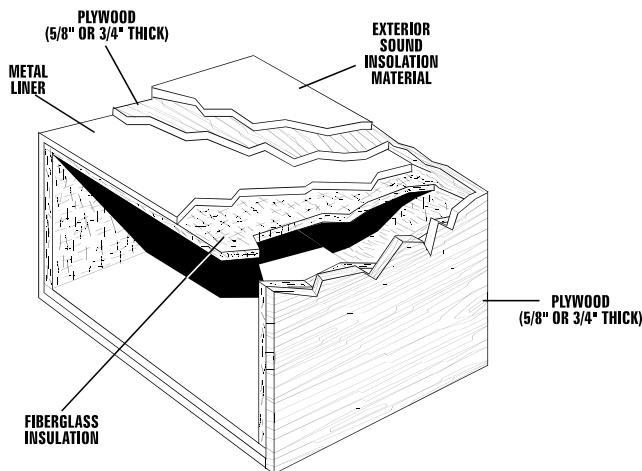

— **! DANGER !** —

- ! Do not install any insulation or other absorbent materials on the interior or underside of the compartment floor.
- Seal all compartment door edges to prevent noise leakage around the door perimeter.

- Line the compartment door interior (except for air openings) with suitable, fire proof sound insulation (such as 1-inch thick fiberglass with a 2-pound density).

It is absolutely essential that an adequate flow of air for cooling, ventilating and engine combustion be supplied to the generator set. Without sufficient air flow, the engine-generator quickly overheats. Such overheating can cause serious operating difficulties and may also cause fire and personal injury. The installer must make sure that sufficient air is available to the generator for cooling, ventilating and combustion. The installer must also provide for a path for exhausting the cooling air to the exterior of a compartment, if so equipped.

— **! DANGER !** —



Never use discharged cooling air for heating or permit such air to enter the vehicle interior. This air contains deadly carbon monoxide gas and other poisonous, flammable or explosive gases.

2.3 COOLING AND VENTILATING AIR

◆ 2.3.1 GENERATOR AIR FLOW

Engine operation drives cooling fans for the 2-stage cooling air system. A pressure fan draws cooling air into the top of generator and into the side of the control panel (Figure 2.9). This air flow cools the engine-generator and electronic components. The second part of the cooling system, a suction fan, draws air that is heated from a hot engine into a collector pan at the base of the unit. This heated air (although cooler than exhaust muffler) is directed across the muffler to cool it. The heated air flow is then deflected out the bottom toward the ground.

Figure 2.9 — Air Flow Through Engine-Generator

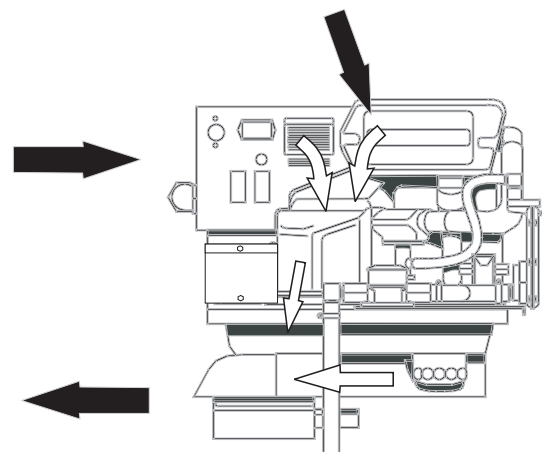

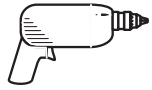

◆ 2.3.2 COOLING AIR INLET OPENINGS

Ideally, you should provide three air inlet openings, whether the generator is housed in a conventional compartment or not. Two of the openings should be 10 square inches and located as shown in Figure 2.10. The third opening should provide for a minimum of 40 square inches unrestricted and be located lower on the compartment door.

NOTE:

Screening, louvers, or expanded metal that cover air openings restrict air flow that you must compensate for by making the actual air opening proportionately larger. See “Compensating for Restrictions.”

For conventional compartment mounted units, the air inlet is generally provided in the compartment door.

Figure 2.10 — Air Inlet in Compartment Door

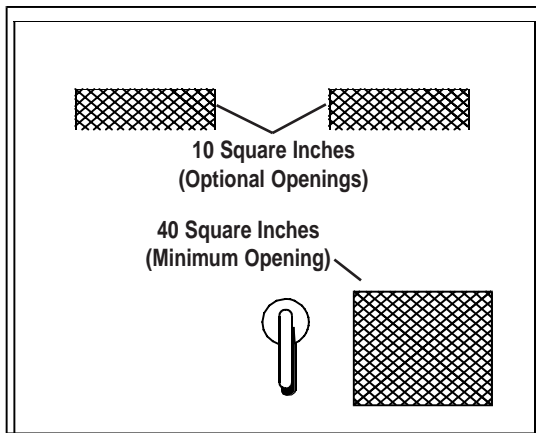

IMPORTANT: IF YOU PLAN TO INSTALL THE GENERATOR IN A COMPARTMENT, BE SURE TO LEAVE AT LEAST ONE INCH (2" recommended) OF CLEARANCE BETWEEN THE GENERATOR AND COMPARTMENT WALLS AND CEILING. INCLUDE 26 GAUGE GALVANIZED STEEL LINING AND SOUND INSULATION WHEN YOU MEASURE FOR THIS 1 INCH (2" recommended) CLEARANCE.

When the unit is installed on a suspended mounting system, one of several different methods of supplying air flow may be used as follows:

- Provide a door in the vehicle skirt having an air inlet opening (Figure 2.11).

Figure 2.11 — Suspended Mount Inlet Door

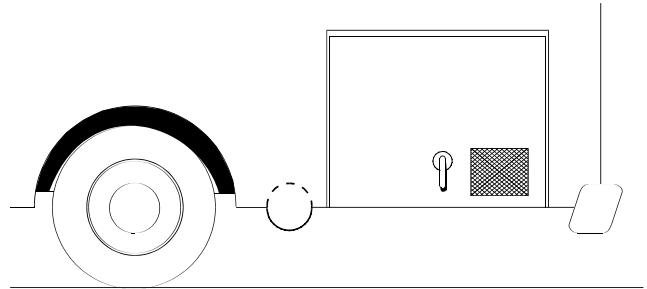

- Using ductwork (Figure 2.12). The installer must be sure air is available to the top of the generator since air inlets are located at the top.

Figure 2.12 — Air Inlet Using Ductwork

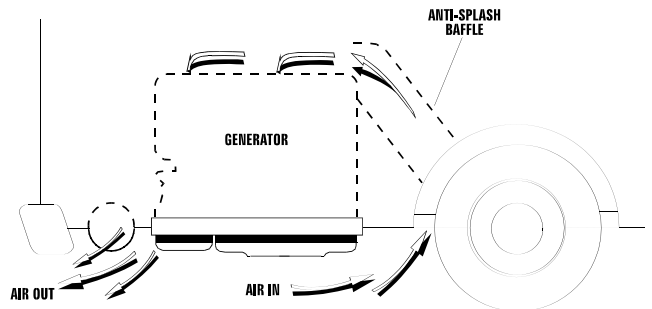

- By providing an opening in the vehicle skirt and space above the generator for cooling air flow (Figure 2.13). Recommended clearance above the top of the generator is at least 2 inches.

Figure 2.13 — Air Inlet in Vehicle Skirt

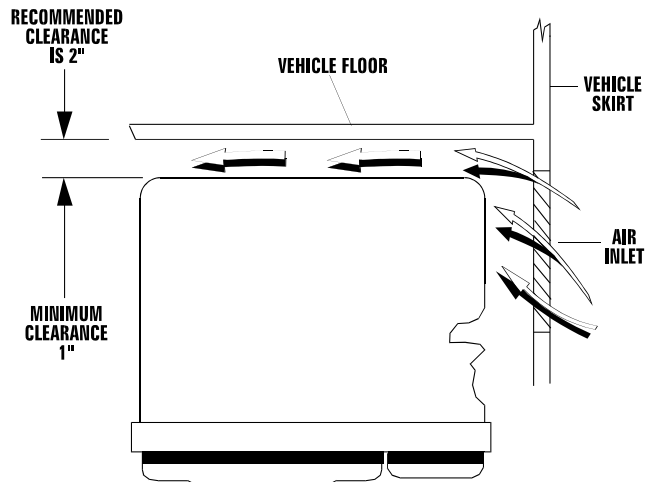

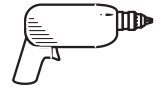

◆ 2.3.3 COMPENSATING FOR RESTRICTIONS

Such materials as screening, louvers, or expanded metal can restrict the free flow of air. Compensate for this restriction by making the actual air opening proportionately larger.

Some materials may offer only a 60 percent “free air inlet area.” Other more efficient materials may provide up to a 90 percent free air inlet area. The percentage of free air inlet opening is usually available from the material supplier or manufacturer.

TO DETERMINE THE ACTUAL AIR INLET OPENING SIZE REQUIRED, DIVIDE 40 SQUARE INCHES BY THE PERCENTAGE OF FREE AIR INLET AREA FOR THE MATERIAL YOU WILL USE.

For example: If you plan to use screening with an 80% free air inlet area, divide 40 by 0.8, which results in 50 square inches. Minimum actual size of air inlet opening in this case is 50 square inches. An opening that measures 4 inches wide by 12-1/2 inches long provides the required air flow (4 x 12.5 = 50 square inches).

◆ 2.3.4 INVERTER LOCATION

The inverter should be located in a dry, well ventilated area in order for the inverter to work effectively. Approximately eight inches of space should be allowed at each end of the inverter for adequate ventilation. **IT SHOULD NOT BE LOCATED IN THE SAME COMPARTMENT AS THE GENERATOR.**

The sensing harnesses supplied with the inverter have a maximum length of 12 feet. If the cables are longer than needed, coil the excess near the inverter unit. If a greater length is needed, contact Generac. **DO NOT ATTEMPT TO SHORTEN OR LENGTHEN THE SUPPLIED sensing harnesses.** The DC power wires may be cut to the required length. Allow enough length to make connection. Coil excess inside J-Box.

◆ 2.3.5 TESTING THE INSTALLATION

Generac recommends testing the installation to be sure adequate cooling air flow is available to the unit before placing the unit into service. If the unit shows signs of overheating, you will need to enlarge the air openings. Never place a unit into service until absolutely certain that cooling and ventilation is adequate.

IMPORTANT: YOU MUST TEST THE INSTALLATION ESPECIALLY IF YOU BRING IN AIR FROM BELOW THE GENERATOR SET.

2.4 GASOLINE FUEL SYSTEM

Installing a gasoline fuel system (Figure 2.14) for recreational vehicle generator sets must comply with applicable codes, standards and regulations. The entire fuel system must be completely free of leaks. There must be no possibility of gasoline vapors entering the vehicle interior.

Figure 2.14 — Generator Fuel System

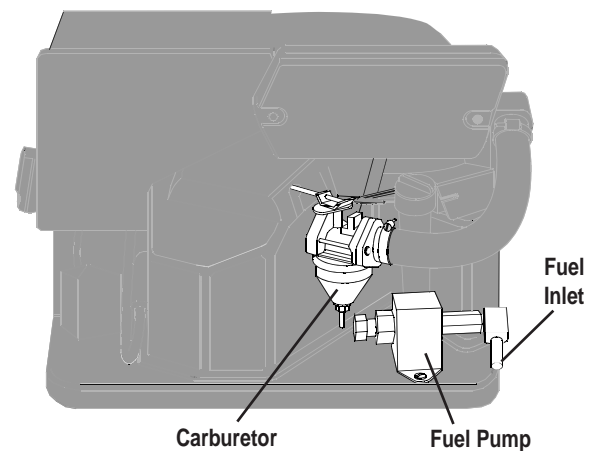

⚠ DANGER ⚠



Gasoline is highly flammable and its vapors are explosive. Comply with all codes, standards and regulations pertaining to gasoline fuel systems used in mobile generators. Properly install and maintain the fuel system and keep it entirely free of leaks. Gasoline vapors must not enter the vehicle interior.

Factory installed generator fuel system components include (a) fuel filter, (b) 12-volt DC electric pump, (c) engine carburetor, and (d) interconnecting lines and fittings. Connect a fuel supply line to the fuel filter inlet. Use a flexible length of approved fuel hose between the fuel filter inlet connection and rigid fuel lines.

◆ 2.4.1 FUEL TANK

Either the generator must share the vehicle engine's fuel tank, or you must install a separate fuel tank for the generator set. All fuel tanks installed on the vehicle must be constructed, installed, restrained so it complies with applicable codes, standards and regulations.

If the generator is to share the vehicle engine's tank, separate fuel pickup tubes are required for the engine and the generator. Generac recommends that you make the fuel pickup tube 2 to 3 inches shorter than the vehicle engine's pickup tube. This prevents the generator from depleting the entire fuel supply during prolonged generator operating periods.

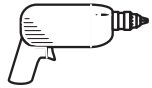

⚠ CAUTION ⚠



Do NOT tee the generator fuel supply line into the vehicle engine fuel supply line. If this is done, the generator will be starved of fuel when both engines are operating at the same time. Also, while the vehicle engine is not running, generator operation may drain the vehicle engine supply line, making it difficult to start the vehicle engine.

⚠ DANGER ⚠



LP (propane) gas is highly explosive. The gas is heavier than air and tends to settle in low areas, where even the slightest spark can ignite it and cause an explosion. Only competent, qualified persons should be allowed to install, test, adjust or service an LP gas fuel system. Install the optional fuel system in compliance with applicable codes, standards and regulations. After the installation, do nothing that might render the system in non-compliance with applicable codes and standards.

◆ 2.4.2 GENERATOR FUEL SUPPLY LINE

▶ 2.4.2.1 Rigid Fuel Lines

Those lines used to supply fuel from a tank to the generator must comply with applicable codes, standards and regulations. The following generator rules apply to rigid fuel lines:

- Rigid lines should be of annealed, seamless, drawn aluminum or steel.
- Lines and fittings must comply with SAE J512F, “Standard Automotive Fittings”, or with ANSI B126.26 (latest edition).
- Route the fuel line so that at least 2 inches of clearance is maintained between the line and any exhaust system parts.
- Do not attach electrical wiring to fuel lines. Route the wiring so it cannot come into contact with any fuel line.
- Route fuel lines so if they leak, fuel does not drip onto any electrical or exhaust system parts.
- Use non-ferrous metal straps without sharp edges to secure fuel lines.

▶ 2.4.2.2 Flexible Fuel Line

Use an approved flexible length of fuel hose between the generator fuel inlet connection and rigid fuel lines. This prevents breaking of the line caused by vibration, shifting, settling or movement. The following rules apply:

- The flexible hose must comply with SAE J30B, “Standard for Fuel and Oil Hose”. It must be approved for use with gasoline.
- The hose should be at least 6 inches longer than is needed to prevent the hose from rupturing if the generator shifts or settles.

2.5 PROPANE GAS FUEL SYSTEM

◆ 2.5.1 PARTS NOT INCLUDED IN FUEL SYSTEM

The propane fuel system does NOT include such items as (a) gas tank, (b) gas piping, (c) fittings, (d) valves, and (e) primary regulator, used to store the gaseous fuel and deliver it to the gaseous fuel solenoid (Figure 2.15).

Figure 2.15 — Diagram of LP Gas System

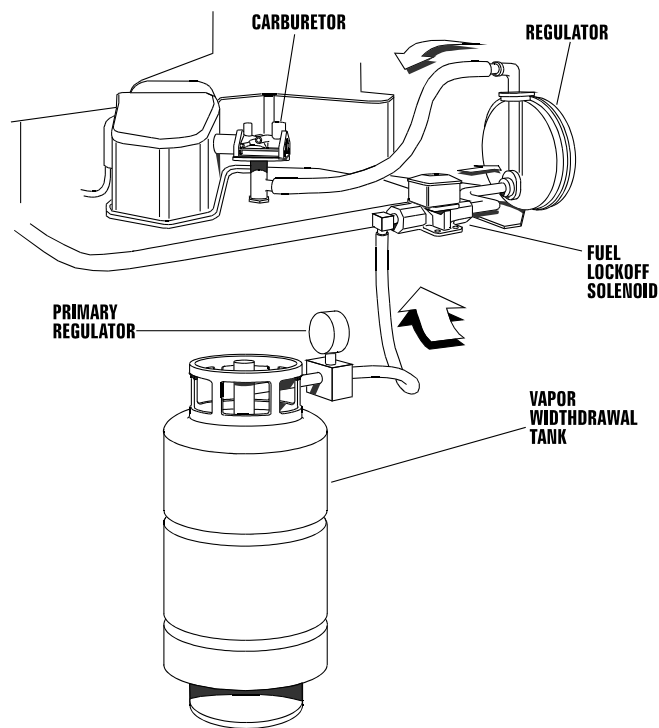

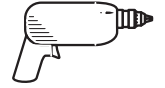

—▲ **DANGER** ▲—



Use only approved components in the gas supply system. All components must be properly installed in accordance with applicable codes. Improper installation or use of unauthorized components may result in fire or an explosion. Follow approved methods to test the system for leaks. No leakage is permitted. Do not allow fuel vapors to enter the vehicle interior.

◆ 2.5.2 SOME IMPORTANT CONSIDERATIONS

When installing an LP gas system, consider seriously the following items:

- All fittings, lines, hoses and clamps must be tight and free of leaks. Apply a pipe sealant to threads when assembling threaded connections. This reduces the possibility of leakage.

Test the entire fuel system for leaks, using approved test methods.

- Optimum gas pressure at the inlet to the gaseous fuel solenoid valve and secondary regulator is 11 inches water column.
- The installer's fuel supply connection point is at the gaseous fuel solenoid valve. This is a 3/4 inch (female) connection. Provide a suitable 3/4 inch NPT (male) connector to attach to the fuel supply line.
- Use a length of approved flexible fuel hose between gaseous fuel solenoid valve and rigid gas piping. The flexible line should be at least six (6) inches longer than necessary.

◆ 2.5.3 VAPOR WITHDRAWAL

Liquid propane (LP) gas is stored in pressure tanks as a liquid. The gas systems used with these generators were designed only for "vapor withdrawal" type systems. Vapor withdrawal systems use the gas vapors that form above the liquid fuel in the tank. Do NOT attempt to use the kit along with any "liquid withdrawal" type system.

◆ 2.5.4 PRIMARY REGULATOR

Gas pressure delivered to the solenoid valve must be properly regulated by means of a primary gas regulator. Mount the primary regulator at the gas tank outlet or in the supply line from the gas tank. The following rules apply:

- For best results, the primary regulator supplies gaseous fuel to the secondary regulator at 11 inches water column. Do NOT exceed 14 inches water column.
- The installer must be sure the primary regulator is rated at sufficient gas flow to operate the generator plus all other gas appliances in the circuit.

NOTE:

Recommended MINIMUM gas flow rate for all air-cooled Impact-34 plus II series generators is 67 cubic feet per hour.

IMPORTANT: IF AN EXISTING PRIMARY GAS REGULATOR DOES NOT HAVE A SUFFICIENT FLOW CAPACITY FOR THE GENERATOR AND OTHER GAS APPLIANCES IN THE CIRCUIT, (a) INSTALL A PRIMARY REGULATOR WITH ADEQUATE FLOW RATE, OR (b) INSTALL A SEPARATE REGULATOR RATED AT LEAST 67 CUBIC FEET PER HOUR. THE INLET SIDE OF ANY PRIMARY REGULATOR THAT SUPPLIES THE GENERATOR MUST CONNECT DIRECTLY TO GAS TANK PRESSURE. DO NOT TEE THE GENERATOR LINE INTO A GAS CIRCUIT FEEDING OTHER APPLIANCES.

◆ 2.5.5 GASEOUS CARBURETION

LP gas vapors should be supplied to the generator regulator inlet at about 11 inches water column (positive pressure). The engine piston draws air in during the intake stroke (Figure 2.16). This air passes through a carburetor venturi which creates a low pressure that is proportional to the quantity of air being pumped. The low pressure from the carburetor venturi acts on the regulator diaphragm, to pull the diaphragm toward the source of low pressure. A lever attached to the diaphragm opens a valve to permit gas flow through the carburetor.

Figure 2.16 — Propane Gas Carburetion Diagram

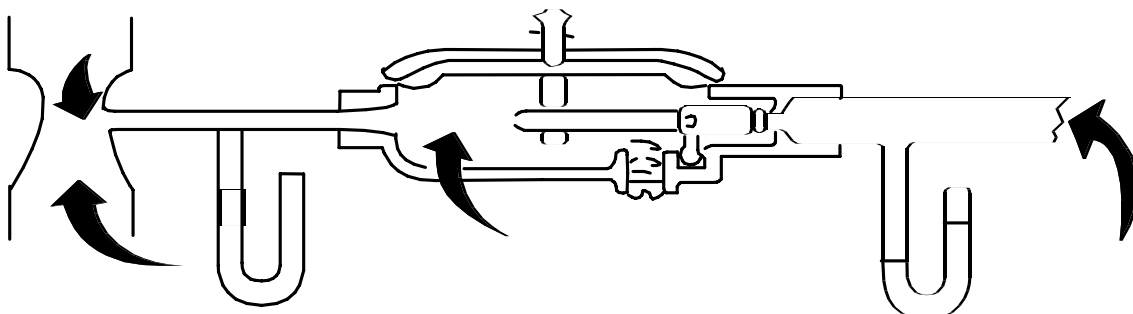

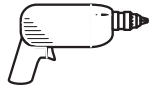

The greater the air flow through the carburetor venturi, the lower the pressure at the venturi throat, the greater the diaphragm movement and the greater the movement of the regulator valve. The more the regulator valve opens, the greater the gas flow that is proportional to air flow through the carburetor.

The following facts about the secondary regulator must be emphasized:

- The regulator must be sensitive to venturi throat pressure changes throughout the operating range.
- The regulator must be properly adjusted so it will stop the flow of gas when the engine is not running (no air flow through the carburetor).
- The slightest air flow (and vacuum) in the venturi throat should move the regulator valve off its seat and permit gas to flow.

◆ **2.5.6 FUEL SUPPLY LINES**

- Propane gas lines must be accessible, but protected against possible damage.
- Do NOT connect electrical wiring to any propane gas fuel line or run wiring alongside the lines.
- Route gas lines away from hot engine exhausts.
- Retain gas lines with metal clamps that do not have sharp edges.
- Install an approved length of flexible hose between the gaseous fuel solenoid valve and rigid fuel supply lines. The flexible line must be non-metallic, non-organic and non-conductive. It must be approved for use with LP gas.

◆ **2.5.7 EXCESS FLOW VALVE**

Propane gas tanks should have an excess flow valve, according to NFPA 501C, Paragraph 3-4.4. This valve and the gas lines must be carefully sized so the valve will close when a fuel line is severed or broken. Consult the Natural-LP Gas Association for information and limitations of excess flow valves.

Manual shutoff valves on the supply tank and elsewhere in the system must be fully open when operating the generator. The excess flow valve functions properly only if all valves are fully open.

◆ **2.5.8 LEAKAGE TESTS**

Do not place the generator into service until you have properly tested the gas system for leaks. To test the system, you need a separate source of 12 volts DC to open the gaseous fuel solenoid valve.

The leak test must comply fully with NFPA, Paragraph 318. All connections, hoses, valves, regulators, fitting, and other fuel system parts must be tested under gas or air pressure of not less than 90 psi (620kPa). while using soap and water or equivalent solution to check for leaks. Other approved methods of testing for leaks may be used, if appropriate. **DO NOT USE ANY FLAME TO TEST FOR LEAKS.**



Gaseous fuel lines between the tank and the secondary regulator are under a positive pressure (about 11 inches water column). Gas pressure at the outlet side of the secondary regulator, however, is a negative pressure (about 1-inch water column) and can draw flame inside a line or fitting and cause an explosion.

2.6 EXHAUST SYSTEM

The generator exhaust system must be safely and properly installed. Only approved mufflers and other exhaust system parts must be used. A properly installed exhaust system must be vapor tight, quiet and completely safe.



Never tee the generator engine exhaust pipe into the vehicle engine exhaust piping. This causes excessive back pressure on the generator engine. Also, water from one engine can damage the other engine.



The generator engine gives off deadly carbon monoxide gas through its exhaust system. This dangerous gas, if breathed in sufficient concentrations, can cause unconsciousness or even death. Symptoms of carbon monoxide poisoning are (a) inability to think coherently, (b) vomiting, (c) twitching muscles, (d) throbbing in temples, (e) dizziness, (f) headache, (g) weakness and sleepiness. If any of these symptoms are experienced, move into fresh air immediately. If symptoms persist, get medical attention. Do not operate the generator until its exhaust system has been inspected and repaired.

◆ **2.6.1 MUFFLERS AND SPARK ARRESTORS**

Exhaust mufflers and spark arrestors that Generac supplies meet code and standard requirements, and are approved by the U.S. Forest Service. Use only mufflers and parts approved by Generac. Any person(s) installing an unapproved muffler, or an unapproved exhaust system part, or modifying an exhaust system in any way that might cause a hazard, is liable for any damage, injury or warranty expense that might be caused by such unapproved installation or modification.

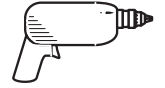

Failure to provide and maintain a spark arrestor may be in violation of the law. If this generator is used on any forest covered, brush covered, or grass covered unimproved land, you must provide a spark arrestor. The vehicle owner or operator must maintain this device in good condition. In the State of California, the preceding is required by law (Section 4442 of the California Public Resources Code). Other states may have similar laws. Federal laws apply on federal lands.

◆ 2.6.2 TYPE OF EXHAUST SYSTEM

- The Impact-36 plus and Impact-34 plus II generators have a configuration for a bottom out exhaust system and is equipped with such an exhaust muffler (Figure 2.17).

Figure 2.17 — Exhaust System

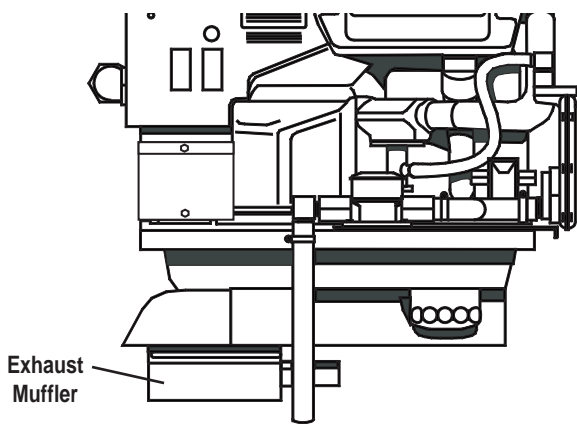

- Nodel 004283-0 Exhaust Adapter mates to the O.D. of the spark arrestor outlet of the muffler. It allows the use of 1-1/4" O.D. exhaust pipe to be clamped in place (Figure 2.18).

Figure 2.18 — Exhaust Adapter

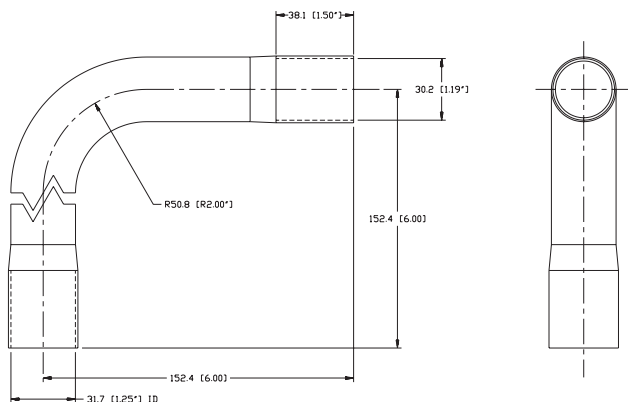

◆ 2.6.3 EXHAUST SYSTEM SAFETY

- Maintain a clearance of at least 3 inches (76mm) between exhaust system parts and any combustible material (such as wood, felt, cotton, organic fibers or other like material). If you cannot maintain the 3-inch clearance, locate, insulate or shield the exhaust part(s) so that the temperature of any combustible material is not raised more than 117°F (65°C) above the ambient air temperature.
- Extend the exhaust system at least one inch (25mm) past the outer edge of the vehicle. Do not terminate the exhaust system under the vehicle.
- Terminate the exhaust tailpipe such that exhaust gases will not be drawn back into the generator compartment and recirculated.
- If there is any possibility of the tailpipe or muffler being damaged, protect these damage prone areas by means of a protective device (such as a "skid bar").
- Install the generator exhaust system according to safe automotive practices.
- Use enough exhaust system hangers to prevent any part of the system from being dislocated.
- Use exhaust system parts recommended by Generac. Using unapproved exhaust mufflers and exhaust system parts is the responsibility of the person(s) installing such unauthorized parts.
- Do not terminate the exhaust system under any opening, window or vent which can be opened or is not permanently sealed from the vehicle interior.
- Exhaust piping must be large enough to prevent excessive back pressure on the generator engine.
- Never tee the generator engine exhaust pipe into the vehicle engine exhaust piping. This causes excessive back pressure on the generator engine. Also, water from one engine can damage the other engine.
- Plan exhaust system installation carefully. Comply with all applicable codes, standards and regulations.

2.7 ELECTRICAL CONNECTIONS

The following general rules apply to electrical connections in a recreational vehicle:

- Qualified electricians who are familiar with applicable codes, standards and regulations should install electrical wiring.
- The wiring should comply with codes, standards and regulations. The National Electric Code (NFPA 70), as well as state and local codes, apply.
- Switches and circuit breakers should be of a type approved for use in recreational vehicles and must be mounted and installed to prevent damage from road shock.

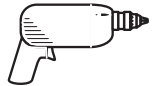

- Wiring must be of adequate size, with approved insulative qualities, and properly supported.
- Conduit and wire openings into generator compartment (if used) must be vapor-sealed, to prevent entry of flammable, explosive or poisonous gases into the vehicle.

◆ 2.7.1 WIRING

- Wiring should be of stranded copper to reduce chance that vibration may cause breakage.
- Wire gauge size of wires should be large enough to handle at least 115% of the installed generator's rated maximum current.
- If neutral conductors are used, they must be the same size as other leg wires.
- Route power supply conductors from generator DC output leads +DC (Red) and -DC (Blue), the return (Black) and the ground (Green) wire through approved flexible conduit, through the compartment floor and to the terminal block located in the DC junction box on the inverter. Refer to ANSI/RVIA standard EGS-1-1993 for conduit selection.
- If flexible metal conduit is used between the generator and the compartment junction box, the conduit end that terminates at the compartment junction box must be vapor-sealed. Flexible metal conduit is NOT vapor tight along its entire length.
- From the AC output junction box on the inverter, route the three wires T1 (Black), T2 (White), and the Green ground wire through approved flexible conduit to either (a) double-pole, double-throw transfer switch, or (b) approved isolation receptacle. Connecting to a transfer switch or isolation receptacle must prevent vehicle electrical circuits from being connected to two different power supplies at the same time (such as generator and dockside power).
- Conductors must be rated 221°F (105°C) or must be of a larger conductor size.

◆ 2.7.2 GENERATOR AC CONNECTION SYSTEM

The Impact plus AC generator output is provided by the remote located inverter module. 120V AC is provided from the terminal block located inside one of the J boxes on the inverter unit (Figure 2.19). The unit is provided with a ground which is connected to the generator and should be connected to the chassis of the recreational vehicle.

Figure 2.19 — Inverter J Box for AC Output

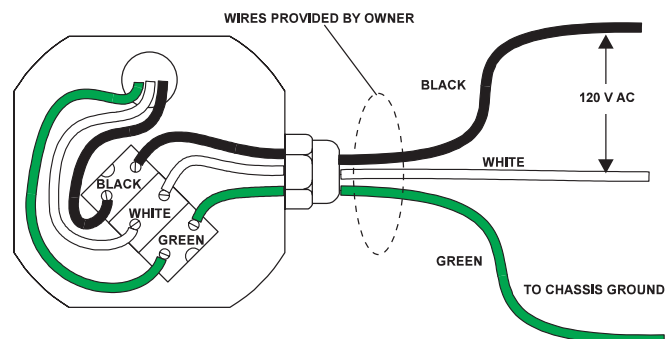

Circuit breaker protection is provided on the generator and protects the unit against overload. Do not apply loads which exceed the rated wattage, or amperage capacity of the generator. Add the watts or amperes of all lighting, appliance, tool and motor loads that the generator will operate at one time. This total should be less than the units rated wattage/amperage capacity.

◆ 2.7.3 ISOLATING DIFFERENT POWER SOURCES

Conductors from the junction box must terminate in a double pole, double throw transfer switch (Figure 2.20). An alternate method for isolating different power sources is by using an isolating receptacle (Figure 2.21). Whichever method you use, you must be certain that both power sources are NOT connected at the same time.

◆ 2.7.4 POWER SUPPLY CORD

The power supply cord must comply with all applicable codes, standards and regulations. It must be large enough to handle the full amperage to which it will be subjected.

◆ 2.7.5 GROUND FAULT CIRCUIT INTERRUPTERS

The National Electric Code (NFPA 70, 551-7) requires that you install ground fault circuit interrupters (GFCIs) on all external and some internal electrical receptacles. Contact your manufacturer or dealer for recommendations.

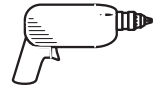

Figure 2.20 — Transfer Switch Isolation Method

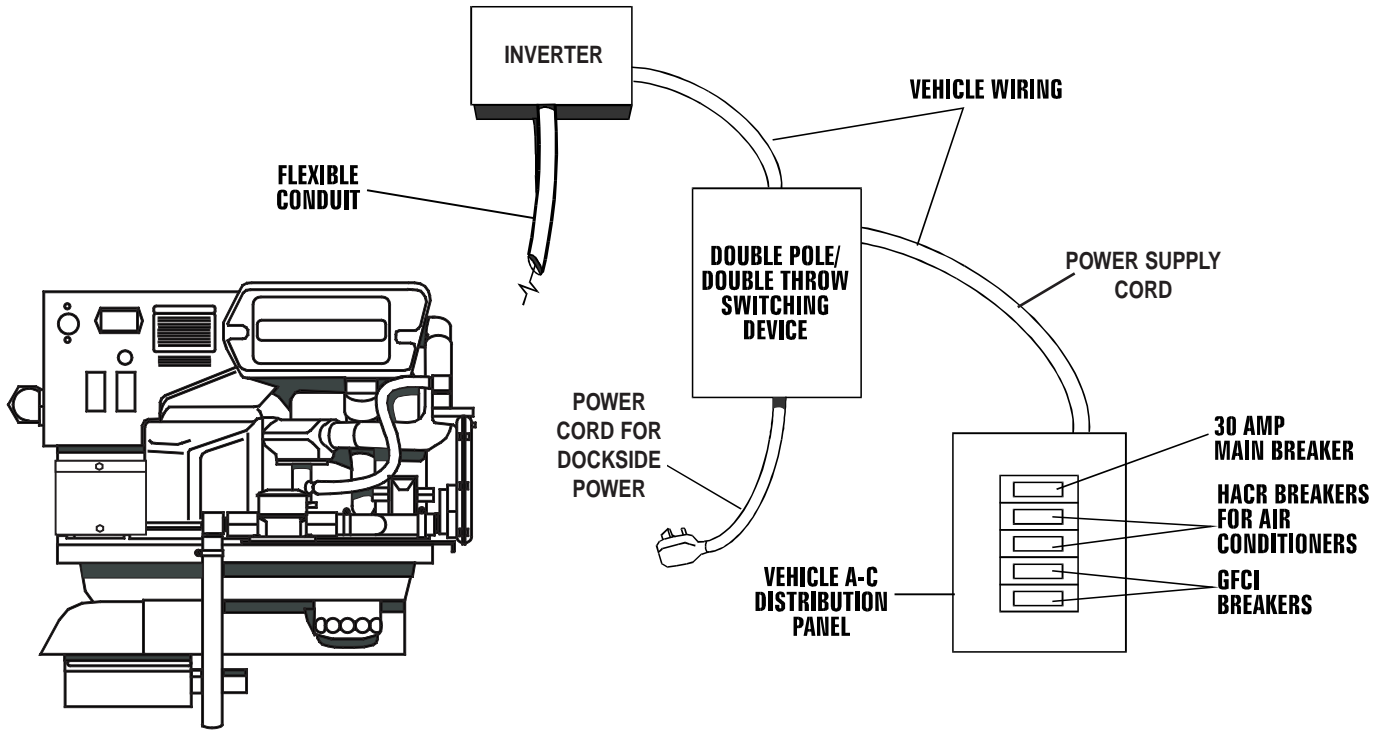
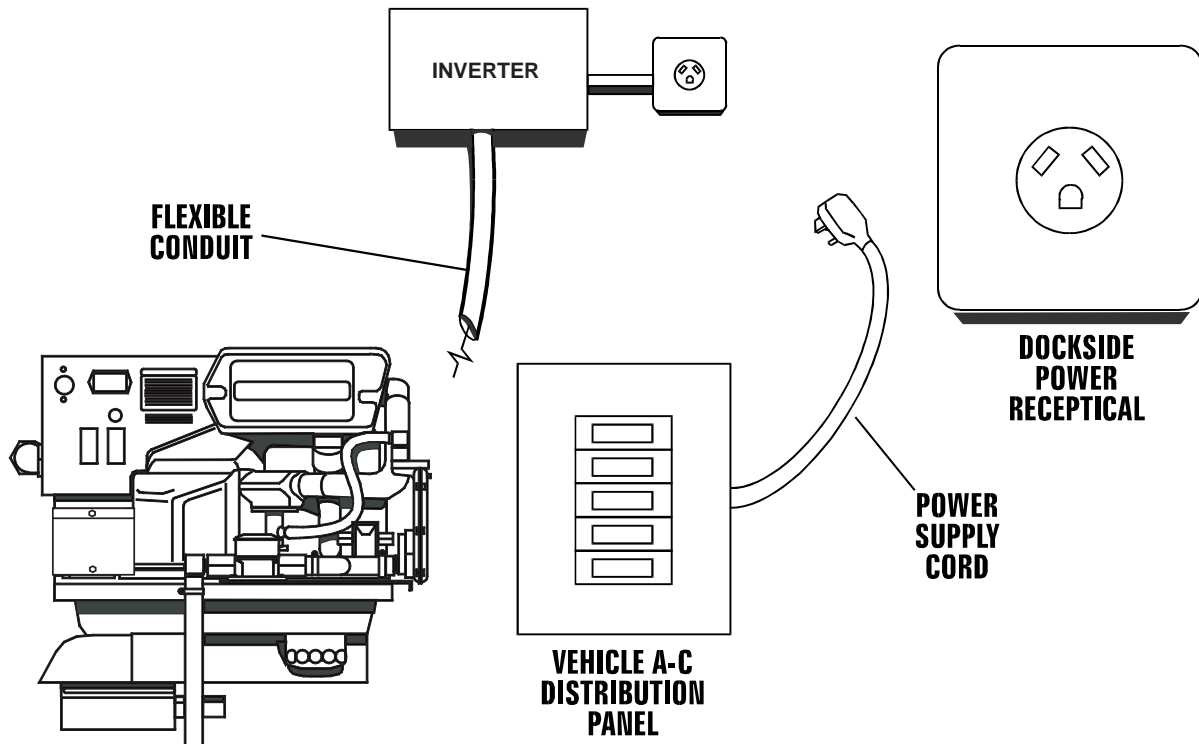
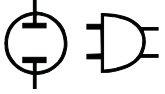

Figure 2.21 — Installation with Isolation Receptacle





◆ 2.7.6 SENSING HARNESS

A sensing harness has been provided with the generator to connect to the inverter (Figure 2.22). It is 12 feet long, however, it is also available in a 24 foot length: Model # 04612-0. The four (4) DC power wires (Red, Blue Black, and Green) may be cut to the desired length to meet the installation (see Figure 2.22).



DO NOT in any way cut or shorten the sensing harness. If the harness is too long, simply tie the excess up neatly with standard cable ties.

2.8 BATTERY INSTALLATION

◆ 2.8.1 RECOMMENDED BATTERY

Install a battery that meets the following requirements:

- Battery must be a 12 volt, automotive type storage battery.

- For prevailing ambient temperatures above 32°F (0°C), use a battery rated 70 amp-hours and capable of delivering 400 cold cranking amperes.
- For prevailing ambient temperatures below 32°F (0°C), use a battery rated 95 amp-hours and capable of delivering 450 cold cranking amperes.

IMPORTANT: IF THE BATTERY IS TO BE USED TO POWER OTHER VEHICLE ACCESSORIES, AS WELL AS START THE GENERATOR, YOU MAY NEED A BATTERY WITH A LARGER CAPACITY.

◆ 2.8.2 BATTERY CABLES

Using battery cables that are too long or too small in diameter may cause a drop in voltage which causes starting problems. For best cold weather starting, the voltage drop between battery terminals and the generator connection point should not exceed 0.12 volts per 100 amperes of cranking current.

Select battery cables based on (a) cable length, and (b) prevailing ambient temperatures. Generally, the longer the cable and the colder the weather, the larger the cable size must be as shown in the following chart.

Figure 2.22 — Generator to Inverter Connection

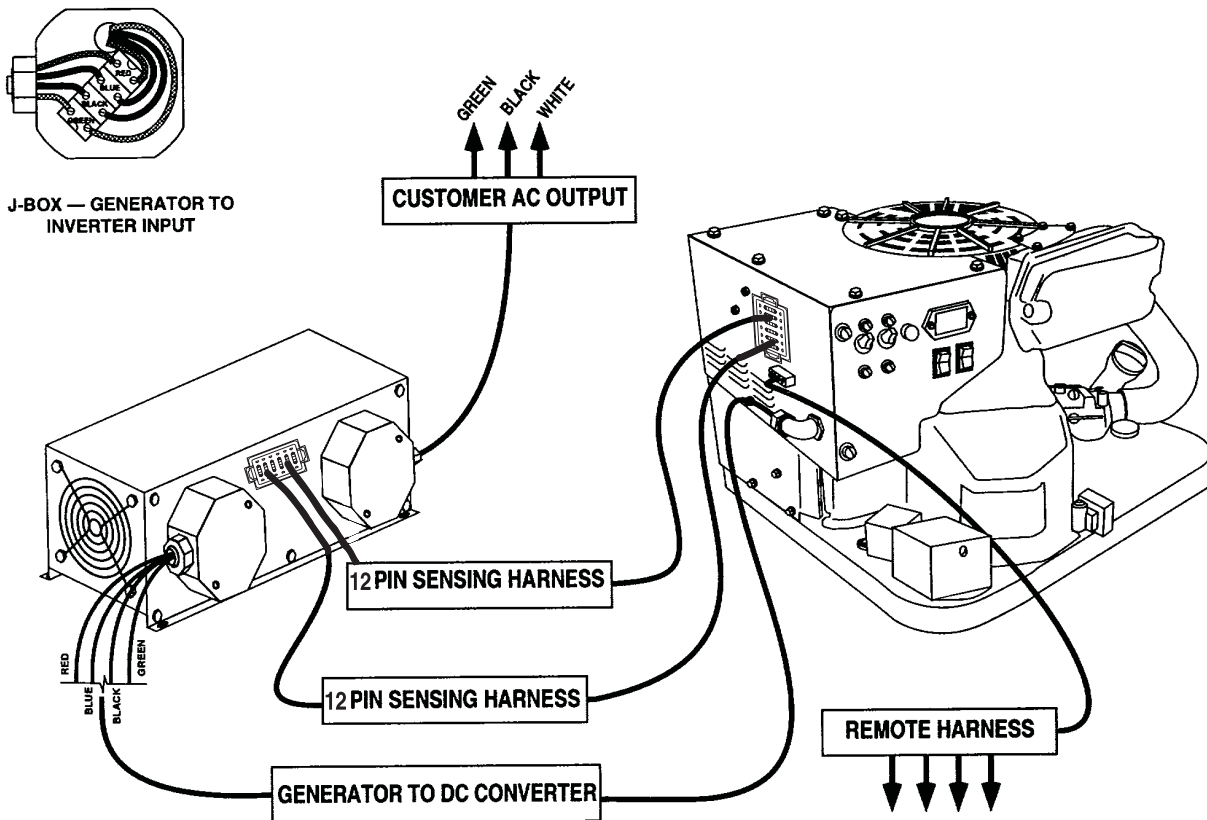

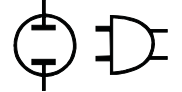

CABLE LENGTH in Feet (Meters)	CABLE SIZE
0 to 10 (0 to 3)	2*
11 to 15 (3.4 to 4.5)	0
16 to 20 (4.9 to 6)	000

* For warm weather, use No. 2 cable up to 20 feet.

◆ **2.8.3 BATTERY CABLE CONNECTIONS**

1. Connect the battery cable from the battery post or terminal indicated by a POSITIVE, POS or (+) to the large lug on the starter contactor as indicated in Figure 2.23.
2. Connect the battery cable from the battery post indicated by a NEGATIVE, NEG or (—) to the frame ground connection.

Figure 2.23 — Connecting Battery Cables

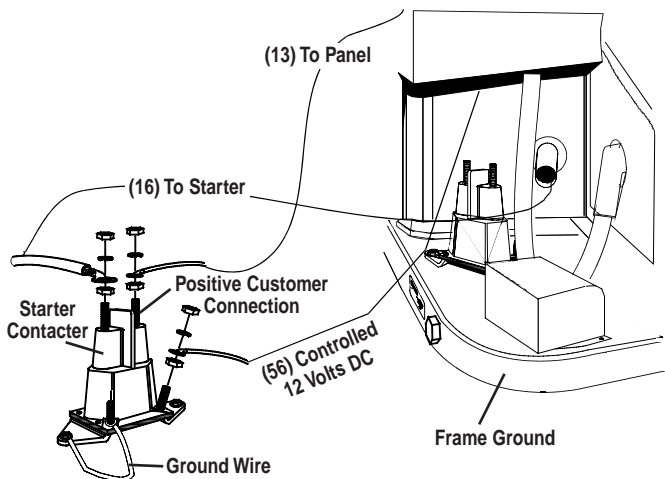

NOTE:

If the generator compartment is grounded to the vehicle chassis, you need not connect a **NEGATIVE** battery cable to the frame ground on the generator base. Connect the negative cable to the frame ground of the chassis.

3. Connect cables so the connections are clean and tight.

◆ **2.8.4 BATTERY COMPARTMENT**

Install the generator battery in its own, vented compartment. Place the battery compartment away from any source of heat, sparks or flame.

Provide ventilation openings in the battery compartment. The minimum size of openings should be 2 square inches at the top of the compartment. Mount the battery on a strong, rigid supporting structure, where leaks and spills of battery fluid will not cause damage.

2.9 OPTIONAL ACCESSORIES

◆ **2.9.1 REMOTE PLUG-IN RECEPTACLE**

A plug-in receptacle (Figure 2.24) is provided on the generator set, near the DC power wires. Use this receptacle to connect an optional remote-mounted start/stop panel to the generator. Installation of such a panel will permit you to start and stop the generator engine from any convenient location inside the vehicle.

Figure 2.24 — Remote Panel Plug-In Receptacle

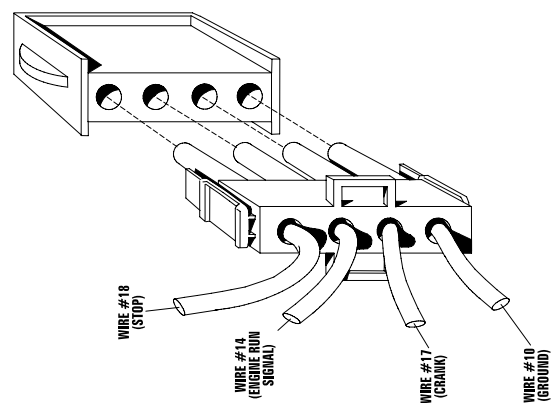

◆ **2.9.2 REMOTE START/STOP PANEL**

A remote mounted Start/Stop panel (Figure 2.25) is available that allows the user to start and stop the generator engine conveniently from inside the vehicle. The remote panel includes a Start/Stop switch, hourmeter, generator run lamp and a wire harness.

Figure 2.25 — Optional Remote Panel (Models 004057 and 004184)

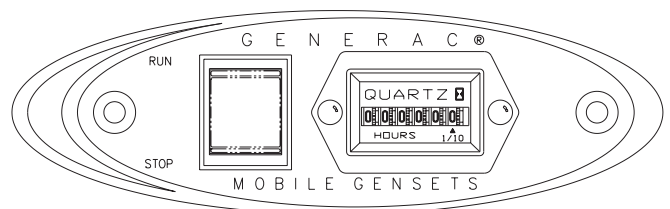

The remote panels mount a rocker type start/stop switch, a “Generator Run” advisory lamp and an hourmeter. The hourmeter should be used in conjunction with the maintenance operations found in Part I of this manual.

- Model 004057 includes the remote panel and a 10 foot long, 4 wire harness.
- Model 004184 includes the remote panel and a 30 foot long, 4 wire harness.

3.1 POST INSTALLATION TESTS

The air cooled Impact-36 plus II generator set was factory tested and adjusted using gasoline as fuel. The air cooled Impact-34 plus II generator set was factory tested and adjusted using LP gas as fuel. You should not be required to adjust the unit any further except under special circumstances.

—  **WARNING**  —



Do not make any unnecessary adjustments. Factory settings are correct for most applications. When making adjustments, however, be careful to avoid overspeeding the engine.

3.2 BEFORE INITIAL START UP

Before starting, complete the following:

1. Check engine crankcase oil level and, if necessary, fill to dipstick FULL mark with the recommended oil. Do not fill above FULL mark.
2. Check the fuel supply. Gas fuel lines must have been properly purged and leak tested in accordance with applicable fuel codes. All fuel shutoff valves in the fuel supply lines must be open.

—  **DANGER**  —



If an LP (propane) gas fuel system has been installed, it must have been properly tested for leaks before operating the system in compliance with ANSI A119.2/NFPA 501C. No leakage is permitted. You must be sure no gaseous fuel vapors enter the vehicle interior.

3.3 INITIAL START

When absolutely certain that the unit has been properly installed and prepared for use, start the engine as follows:

1. Turn off all electrical loads. Do this by setting the generator main circuit breaker to its “OFF” or “OPEN” position.
2. Refer to the Owner’s Manual shipped with unit for cranking and starting instructions. The engine may require more cranking for initial starting since the fuel lines have to be primed (Use of the Primer Switch on gasoline units will shorten this time).

3. Let the engine warm up for about five minutes to allow internal temperatures to stabilize.
4. Carefully inspect the engine-generator for fuel, oil and exhaust system leaks. Before proceeding to the next step, correct any leakage immediately.
5. When all tests and adjustments at no-load are completed, apply electrical loads and check for proper operation under load. See “Testing Under Load”, Section 3.4. Run the unit at least 30 minutes with loads applied.
6. Turn off all electrical loads by setting the generator main circuit breaker to “OFF” or “OPEN.”
7. Let the unit run at no-load for a few minutes to stabilize internal engine-generator temperatures. Then, shut down the engine.

IMPORTANT: THE GENERATOR SET WAS THOROUGHLY TESTED AND ADJUSTED AT THE FACTORY BEFORE SHIPPING. NO ADDITIONAL ADJUSTMENT SHOULD BE NECESSARY. ONLY QUALIFIED SERVICE TECHNICIANS WHO HAVE BEEN TRAINED SHOULD PERFORM ADJUSTMENTS OUTLINED IN THIS MANUAL.

3.4 TESTING UNDER LOAD

Apply electrical loads equal to about 75-100% of the unit’s rated wattage/ampere capacity.

Let the unit run at least 30 minutes with load applied. During this part of the test, check that the unit is not running excessively hot and that adequate cooling air flow is available. You must not allow the unit to overheat during prolonged operation.

NOTE:

The generator engine is equipped with a high temperature switch. The switch has normally-open (N.O.) contacts. When the temperature is too high, switch contacts close, and engine shuts down automatically.

IMPORTANT: GENERAC RECOMMENDS THAT YOU TEST THE GENERATOR FOR ADEQUATE COOLING.

3.5 INSTALLATION CHECKLIST

◆ LOCATION AND SUPPORT

- Generator is properly located.
- Generator is properly supported.
- Generator is properly restrained.

◆ GENERATOR COMPARTMENT

- Compartment construction is proper.
- Holes/Openings are vapor-sealed.
- Compartment size is correct.
- Compartment is vapor-sealed.
- Sound insulation is correct.
- Floor cutouts are properly completed.

◆ COOLING AND VENTILATING AIR

- Airflow is adequate.
- Air inlet opening is correct.
- Compensate for restrictions.
- Check that installation has been tested.

◆ DIESEL FUEL SYSTEM

- Fuel tank complies with all applicable codes.
- Fuel system is properly installed and checked for leaks.

◆ EXHAUST SYSTEM

- Exhaust system complies with all applicable codes.
- Exhaust system is properly and safely installed.

◆ ELECTRICAL CONNECTIONS

- Connections comply with local code requirements and all National Electrical Codes.
- Junction box is properly installed.
- Wiring meets all standards.
- All connections are correct.
- Conduit is properly installed and sealed.
- Generator is properly bonded to the vehicle.

◆ BATTERY INSTALLATION

- Recommended battery is installed.
- Recommended cables are installed.
- Cables are clean and tight.
- Cables are connected properly.
- Proper ventilation is provided.
- Terminals are coated with anti-corrosion grease, and terminal covers are positioned.

◆ OPTIONAL ACCESSORIES

- Check that remote start/stop panels (if used) are installed properly.
- Check that all other options and accessories (if used) are installed properly.

◆ POST INSTALLATION TESTS

- Check that all tests are completed properly.

DATE OF INSTALLATION _____

NAME OF INSTALLER _____

SIGNATURE OF INSTALLER _____



4.1 TROUBLESHOOTING GUIDE

PROBLEM	CAUSE	CORRECTION
Engine won't crank.	<ol style="list-style-type: none"> 1. Fuse is blown. 2. Loose corroded or defective battery cables. 3. Defective engine Start/Stop switch. 4. Defective starter contactor. 5. Defective starter motor. 6. Low or defective Battery 	<ol style="list-style-type: none"> 1. Replace 15 amp fuse. 2. Tighten, clean or replace as necessary. 3. Replace Start/Stop switch. 4. Replace contactor. 5. Replace starter motor. 6. Charge or replace battery.
Engine cranks but won't start, low full load power.	<ol style="list-style-type: none"> 1. Out of fuel. 2. Fuel pump is defective (Gasoline), OR, fuel solenoid is defective (LP). 3. Open Wire #14 from Eng. Control Bd. 4. Engine is flooded. 5. Spark plug defective. 6. Loose spark plug boot. 	<ol style="list-style-type: none"> 1. Replenish fuel. 2. Replace defective fuel pump or fuel solenoid. 3. Reconnect wire. 4. Wait 5-10 min. before trying. 5. Clean, regap or replace plug. 6. Press boot on securely.
Engine starts hard, runs rough.	<ol style="list-style-type: none"> 1. Air cleaner plugged or damaged. 2. Defective spark plug. 	<ol style="list-style-type: none"> 1. Clean or replace as needed. 2. Clean, regap or replace plug.
Engine starts, shuts down when Start/Stop switch is released.	<ol style="list-style-type: none"> 1. Engine oil is low. 2. Engine is overheated. 3. Defective Low Oil Pressure System 4. Defective Control Board 5. Defective Computer Control Board. 	<ol style="list-style-type: none"> 1. Check oil; add as needed. 2. Check adequate ventilation. 3. Have serviced/replaced. 4. Have board serviced/replaced. 5. Have board serviced/replaced.
Start/Stop switch at Stop, engine continues to run.	<ol style="list-style-type: none"> 1. Defective Start/Stop switch 2. Open/disconnected wire #18 between Start/Stop switch and Control 3. Open/disconnected wire #0 between Start/Stop switch & Control Bd. 4. Defective Control Board 	<ol style="list-style-type: none"> 1. Replace switch. 2. Reconnect or close wire. 3. Reconnect or close wire. 4. Replace board.
No output from generator.	<ol style="list-style-type: none"> 1. Check circuit breaker. 2. Check vehicle circuit breaker & fuses. 3. Transfer sw. set to NORMAL position. 4. Generator internal failure. 5. Inverter defective. 	<ol style="list-style-type: none"> 1. Reset to ON or CLOSED. 2. Reset and replace if necessary. 3. Set to GENERATOR position. 4. Take generator to an Authorized Generac facility. 5. Take generator to an Authorized Generac facility.

Section 5 – Electrical Data

IMPACT-36 plus II Recreational Vehicle Generator
Major Features and Dimensions – Drawing No. 0D4952

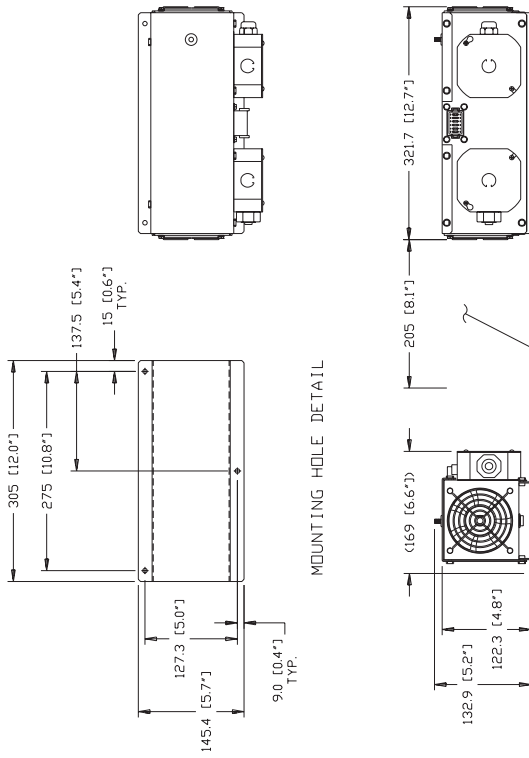
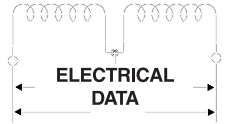

ALLOW APPROXIMATELY
8" FOR AIRFLOW ON
BOTH ENDS OF INVERTER

NOTE:
1. ALL DIMENSIONS IN MM INCHES

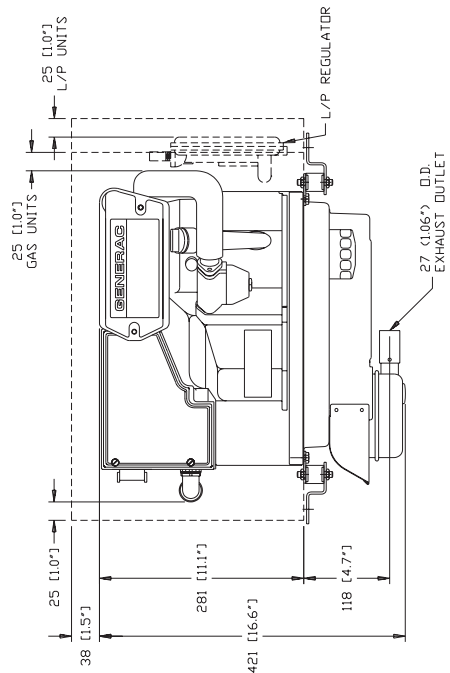
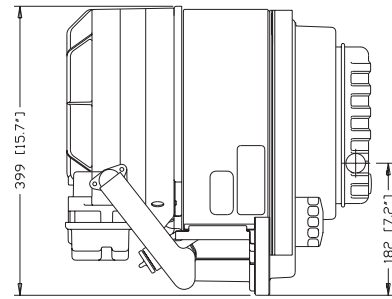
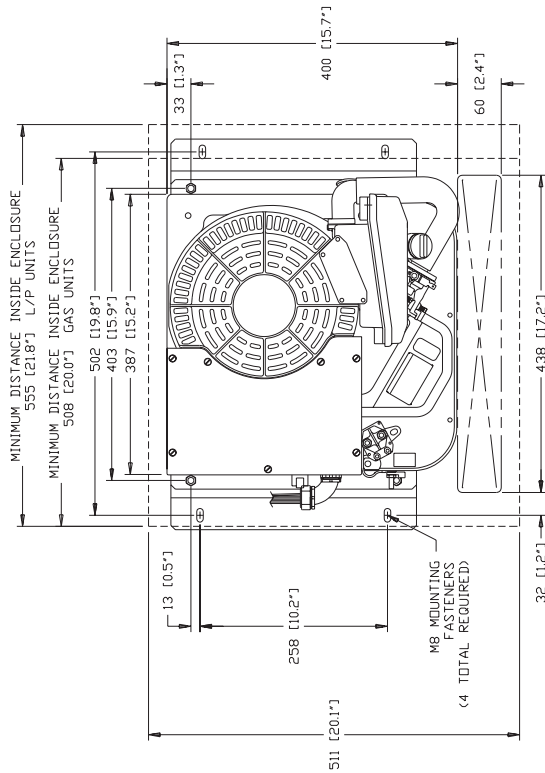

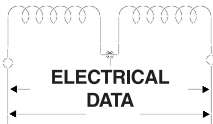

Section 5 – Electrical Data

IMPACT-36 plus II Recreational Vehicle Generator Wiring Diagram and Schematic – Drawing No. 0D4947-B

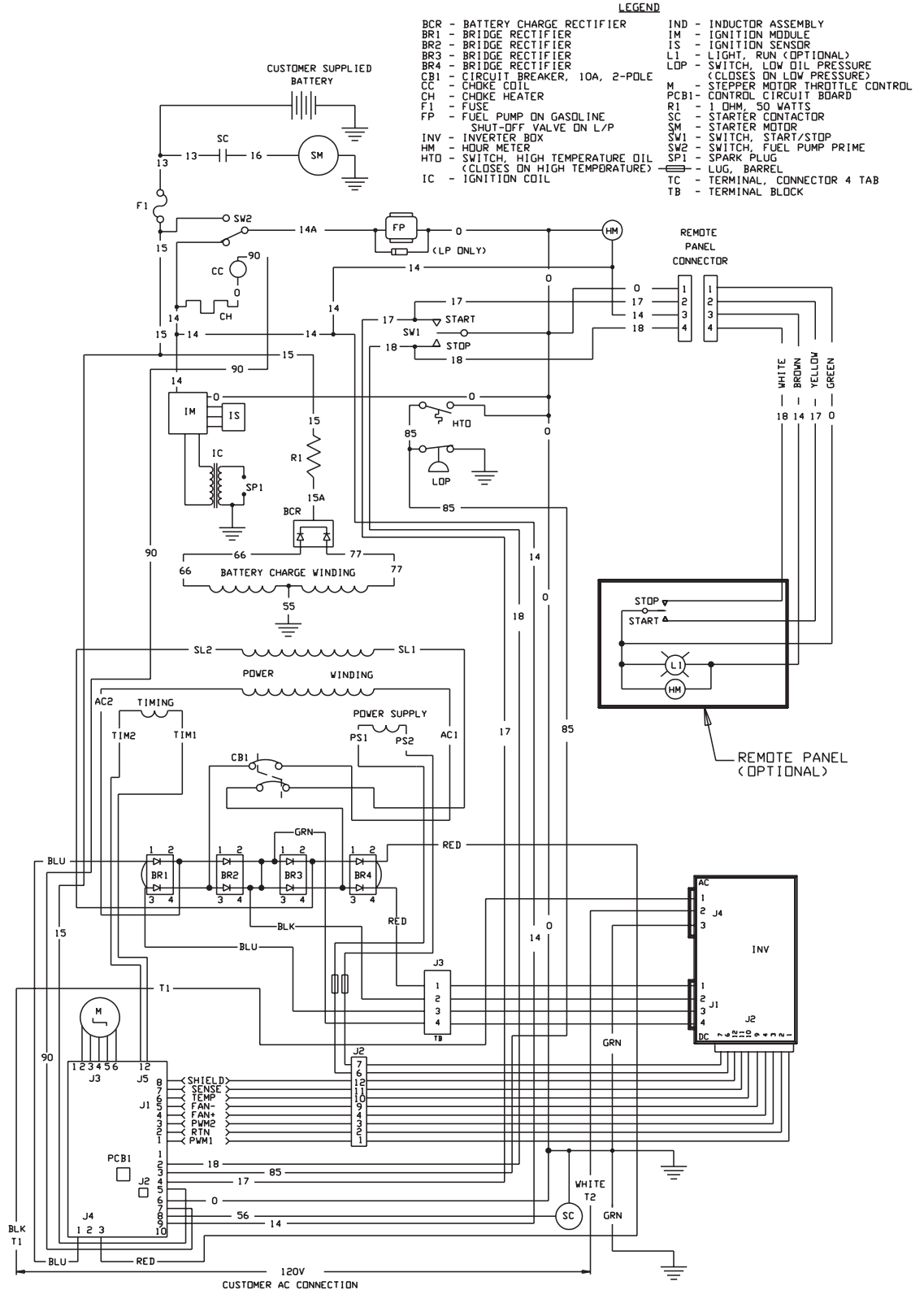

Section 5 – Electrical Data
IMPACT-36 plus II Recreational Vehicle Generator
Wiring Diagram and Schematic – Drawing No. 0D4947-B

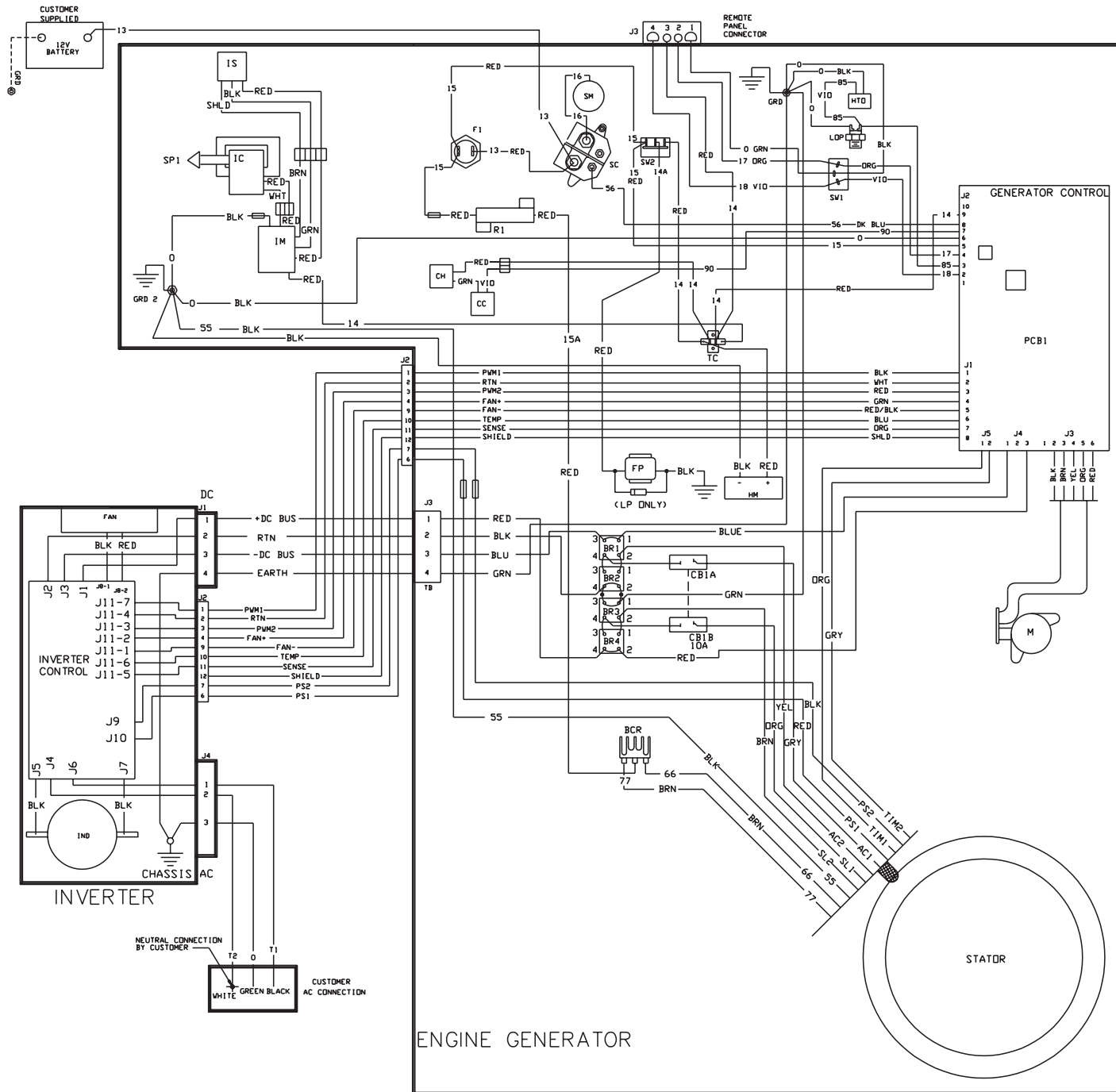
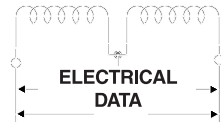

Section 6 – Exploded Views and Parts Lists

**IMPACT-36 plus II Recreational Vehicle Generator
Control Panel – Drawing No. 0D4946-A**

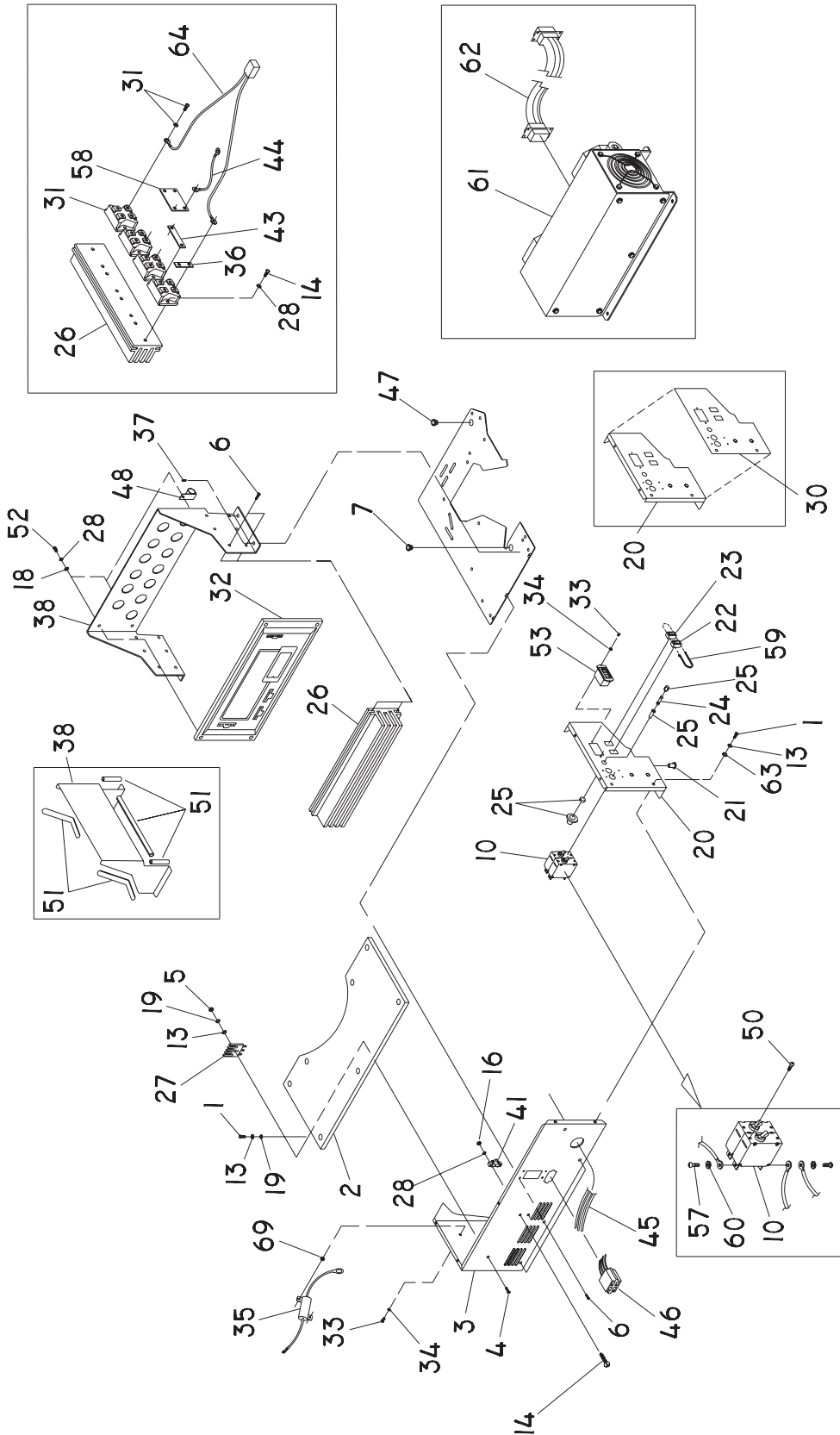

****ITEMS #49, 65 & 66-HARNESSES- NOT SHOWN FOR CLARITY**

Section 6 – Exploded Views and Parts Lists

IMPACT-36 plus II Recreational Vehicle Generator Control Panel – Drawing No. 0D4946-A

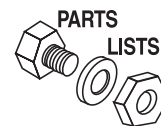

ITEM	PART NO.	QTY.	DESCRIPTION
1	091526	7	M5-0.8 X 12MM PHILLIPS PAN HD. MACH. SCR.
2	020093	1	BOX, CONTROL TOP
3	0D4226	1	BOX, CONTROL PANEL
4	036937	1	#10-32 X 1" PHILLIPS PAN HD. MACH. SCR.
5	022158	1	#10-32 HEX NUT
6	074908	8	TAPTITE M5- .8 X 10MM
7	023484M	1	SNAP BUSHING
10	0A8592	1	CIRCUIT BREAKER,15A.
13	049226	6	LOCK WASHER-M5
14	075476	10	M4-0.7 X 16MM
16	051715	2	M4-0.7 HEX NUT
18	022985	4	M4 FLAT WASHER
19	023897	8	M5 FLAT WASHER
20	0A9179	1	CONTROL PANEL, FRONT
21	030809	1	RUBBER GROMMET
22	087798	1	SWITCH, SPDT ROCKER
23	092113	1	SWITCH, SPSTMOM ROCKER
24	0A9611	1	FUSE, 7.5A. AGC
25	032300	1	FUSE HOLDER
26	0A6422	1	EXTRUSION, CONTROLLER
27	065795	1	RECTIFIER, BATTERY CHARGE
28	022264	14	LOCK WASHER-M4
30	0C2336	1	PANEL DECAL
31	096874	4	DIODE, DUAL 30A
32	0A6060	1	ASSEMBLY, PCB CCG
33	043181	4	PHMS M3-.05 X 10MM
34	043182	4	LOCK WASHER-M3
35	089744	1	RESISTOR, POWER 1 OHM
36	0A6423A	2	BUS BAR, OUTER
37	045756	4	TAPTITE M6- 1.0 X 10MM
38	086722	1	BRACKET, HEAT SINK-PCB
41	075210A	1	TERMINAL BLOCK
43	0A6423B	4	BUS BAR, INNER
44	0912970025	1	GROUND WIRE
45	0A6470	1	DC POWER HARNESS
46	091269A	1	REMOTE PANEL HARNESS
47	023484D	1	SNAP BUSHING
48	082121A	1	CLAMP, CONTROL PANEL HARNESS
49	0A9183	1	HARNESS, CONTROL PANEL
50	025105	4	#6-32 X 1/4" PHILLIPS ROUND HD. MACH. SCREW
51	084867	3.5	RUBBER U-CHANNEL
52	051718	4	M4-0.7 X 10MM HEX HEAD CAPSCREW
53	0C1457	1	HOUR METER
57	036933	4	PPHMS 10-32 X 3/8" LG
58	0A6423C	1	BUS BAR, CENTER
59	029333A	1	BLACK TIE WRAP, 7" LG
60	023762	4	SHAKEPROOF EXT. #10
61	0D4885	1	INVERTER ASSEMBLY
62	0D4884	1	WIRE HARNESS
63	020769	2	M6 FLAT WASHER
64	0A6464	1	WIRE HARNESS-HEATSINK TO PCBI
65	0D4882	1	HARNESS-PCBI TO PANEL
66	0A6700	1	HARNESS-HEATSINK TO TERM. BLOCK
69	051714	2	M3-0.5 NUT

Section 6 – Exploded Views and Parts Lists
IMPACT-36 plus II Recreational Vehicle Generator
Impact-34 plus II Sheet Metal – Drawing No. 0A9193-J

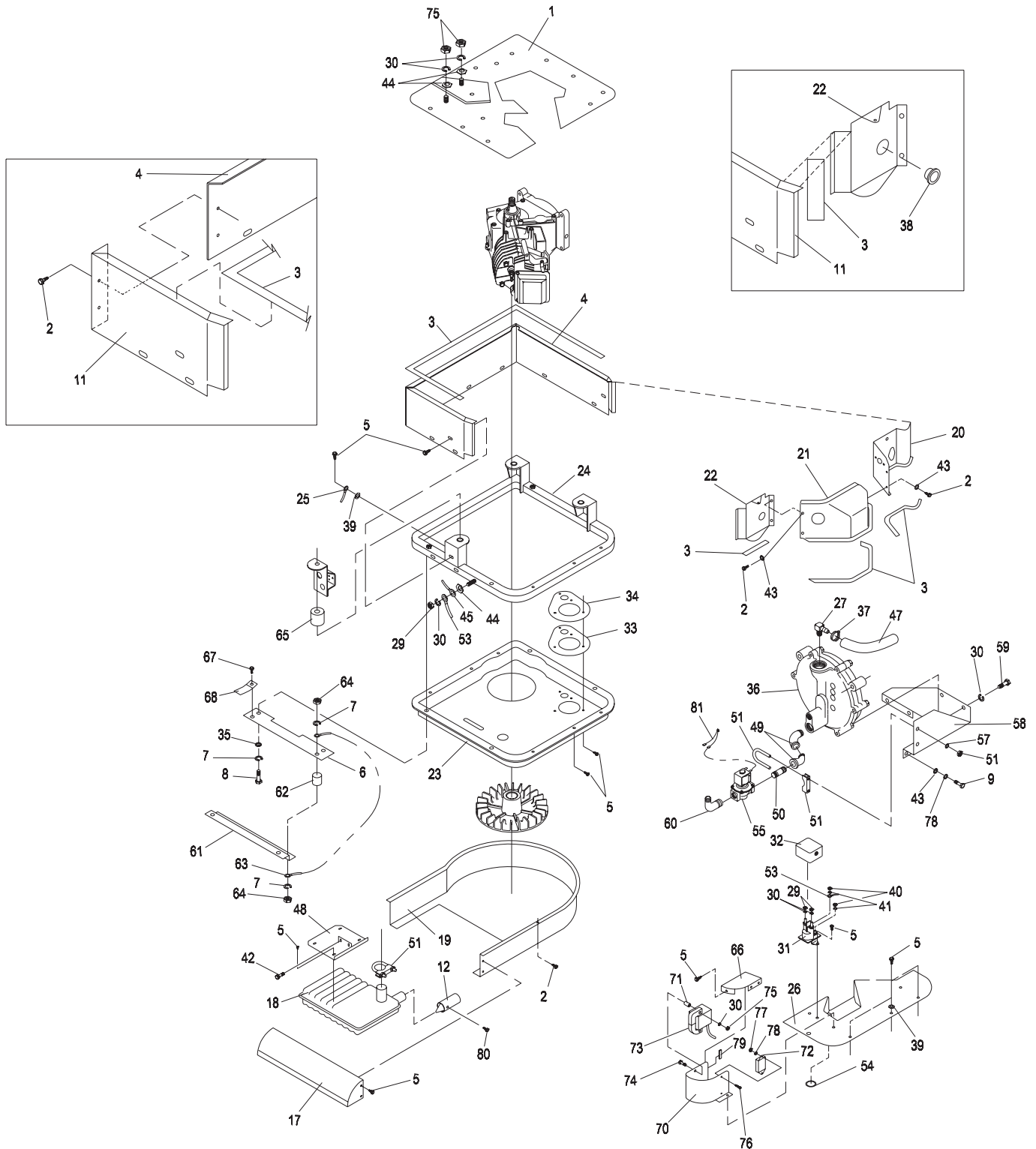

Section 6 – Exploded Views and Parts Lists
IMPACT-36 plus II Recreational Vehicle Generator
Impact-34 plus II Sheet Metal – Drawing No. 0A9193-J

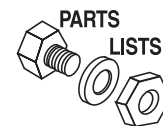

ITEM	PART NO.	QTY.	DESCRIPTION	ITEM	PART NO.	QTY.	DESCRIPTION
1	086705	1	PLATE, DIVIDER	43	023897	7	FLAT WASHER #10/M5
2	056893	32	CRIMPTITE 10-24 x 1/2"	44	0A1658	3	SPECIAL LOCK WASHER, M6
3	086718	3.5'	SEAL, RUBBER EXTRUSION	45	0742600103	1	GROUND STRAP, UNIT
4	0A3666	1	BOX, WRAPPER	47	047290	1	HOSE-3/8" I.D. x 11-1/2" LONG
5	074908	31	TAPTITE, M5-.8 x 10MM	48	092000	1	BRACKET, MUFFLER HANGER
6	0A3667	2	MOUNTING RAILS	49	025425	2	STREET ELBOW 45 DEG. 3/4" NPT
7	022129	12	M8 LOCK WASHER	50	026490	1	PIPE NIPPLE 3/4" x 2"
8	039414	4	M8-1.25 x 35MM HEX HD. CAPSCR.	51	094670	2	U BOLT W / SADDLE & 2-NUTS
9	050830	3	HHCS M5-0.8 x 40MM	53	0912970071	1	STARTER CONTACTOR GROUND WIRE
11	0A3638	1	WRAPPER, END PANEL	54	089045	1	SEAL, WASHER EXHAUST PIPE
12	089680	1	SPARK ARRESTER	55	0A2666	1	FUEL SOLENOID 12V DC
17	089471	1	DEFLECTOR, AIR OUT	57	022145	2	5/16" FLAT WASHER
18	086731A	1	ASSEMBLY, MUFFLER	58	0A4603	1	BRACKET L/P
19	086715	1	HOUSING, LOWER FAN	59	022507	2	CAPSCR., HEX HD.-1/4"-20 x 1/2"
20	086726	1	SKIRT, CARB. BAFFLE	60	0A5606	1	LP HOOK-UP FITTING
21	086671	1	COVER, ROCKER COVER	61	0A3764	2	CUSTOMER MOUNTING BRACKET
22	086727	1	SKIRT, SPARK PLUG SIDE	62	066443B	4	VIBRATION MOUNT
23	086719	1	PAN, BELLY	63	020668	2	EARTHING STRAP
24	0C3296	1	FRAME	64	045771	8	HEX NUT-M8
25	090141A	1	GROUND STRAP	65	038353	3	VIBRATION MOUNT
26	086724	1	PLATE, BASE COVER	66	0A9196	1	COVER, IGNITION BRACKET
27	043790A	1	BARBED EL 90 3/8NPT X 3/8 VS	67	079119	1	1/4"-20 TAPTITE 1-1/4"
29	022127	5	HEX NUT, 1/4"-20	68	0A7213	1	TAG, BOLT REMOVAL
30	022097	9	LOCK WASHER-1/4"-M6	70	0A9172	1	BRACKET, IGNITION SYSTEM
31	086729	1	CONTACTOR, STARTER	71	089047	2	SPACER, IGNITION COIL
32	090518	1	BOOT, CONTACTOR	72	086711	1	MODULE, IGNITION
33	089048	1	SEAL, OIL FILTER HOLE	73	089049B	1	ASSEMBLY, IGNITION COIL
34	090537	1	RETAINER, SEAL	74	049721	2	M6-1.0 x 35MM HEX HD. CAPSCREW
35	022145	4	FLAT WASHER-M8	75	049813	4	M6-1.0 HEX NUT
36	075211	1	REGULATOR	76	091526	2	M5-0.8 x 12MM PHILLIPS PAN HD. MACH. SCR.
37	040173	1	HOSE CLAMP #5.5	77	051716	2	M5-0.8 HEX NUT
38	023484D	1	SNAP BUSHING	78	049226	5	LOCK WASHER, M5
39	0A8475	2	SPECIAL LOCK WASHER, M5	79	084867	5	RUBBER "U" CHANNEL
40	022471	2	#8-32 HEX NUT	80	056892	1	CRIMPTITE #10-24 x 3/8"
41	022264	2	#8 LOCK WASHER	81	0A9031	1	WIRE ASSEMBLY, BLOCKING DIODE
42	079246	2	HEX HD. CAPS., M6-1.0 x 16MM-W/L-WASHER				

Section 6 – Exploded Views and Parts Lists
IMPACT-36 plus II Recreational Vehicle Generator
Impact-36 plus Sheet Metal – Drawing No. 0A9194-H

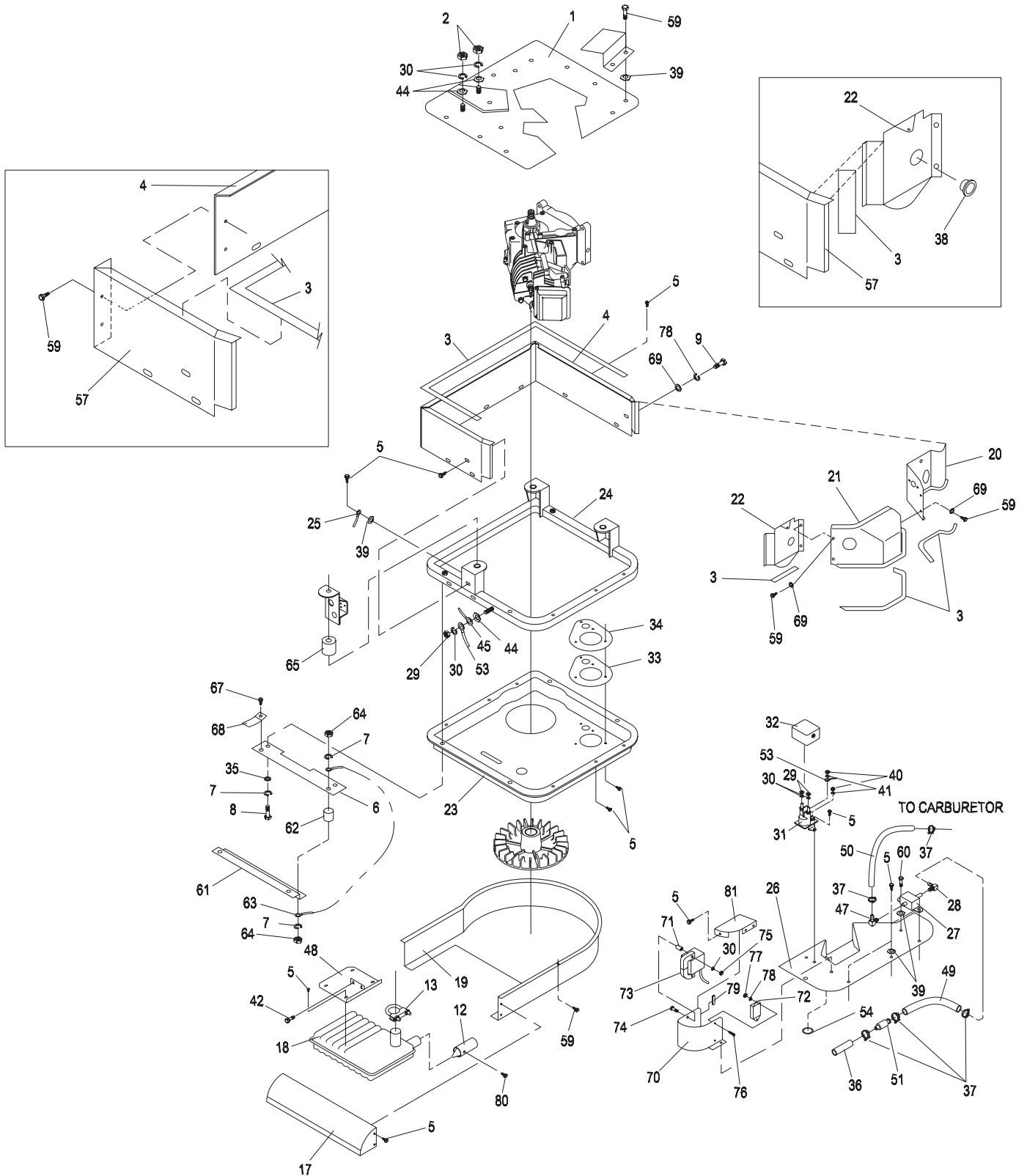

Section 6 – Exploded Views and Parts Lists
IMPACT-36 plus II Recreational Vehicle Generator
Impact-36 plus Sheet Metal – Drawing No. 0A9194-H

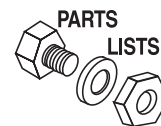

ITEM	PART NO.	QTY.	DESCRIPTION	ITEM	PART NO.	QTY.	DESCRIPTION
1	086705	1	PLATE, DIVIDER	42	079246	2	HEX HD. CAPSCR. M6-1.0 x 16MM-W/LOCKWASHER
2	049813	2	M6-1.0 HEX NUT	44	0A1658	3	SPECIAL LOCK WASHER, M6
3	086718	3.5 FT.	SEAL RUBBER EXTRUSION	45	0742600103	1	GROUND STRAP, UNIT
4	0A3666	1	WRAPPER, BOX	47	039450	1	1/8" x 3/16" NPT 90 DEG. BARBED FITTING
5	074908	31	TAPTITE, M5-.8 x 10MM LONG	48	092000	1	BRACKET, MUFFLER HANGER
6	0A3667	2	MOUNTING RAILS	49	030340	1	1/4" FUEL LINE (8" LONG)
7	022129	12	M8 LOCK WASHER	50	082580D	1	3/16" CARBURETOR LINE (4" LONG)
8	039414	4	M8-1.25 x 35MM HEX HD. CAPSCR.	51	086311	1	FUEL FILTER
9	050830	2	HHCS M5-0.8 x 40MM	53	0912970071	1	STARTER CONTACTOR GROUND WIRE
12	089680	1	SPARK ARRESTOR	54	089045	1	SEAL, WASHER EXHAUST PIPE
13	094670	1	U-BOLT, W/SADDLE & NUTS	57	0A3638	1	PANEL, WRAPPER BOX
17	089471	1	DEFLECTOR, AIR OUT	59	056893	13	CRIMPTITE #10-24 x 1/2"
18	086731A	1	ASSEMBLY, MUFFLER	60	052618	1	HEX HD. CAPSCR., M5-0.8 x 12 G8.8
19	086715	1	HOUSING, LOWER FAN	61	0A3764	2	CUSTOMER MOUNTING BRACKET
20	086726	1	SKIRT, CARB. BAFFLE	62	066443B	4	VIBRATION MOUNT
21	086671	1	COVER, ROCKER COVER	63	020668	2	EARTHING STRAP
22	086727	1	SKIRT, SPARK PLUG SIDE	64	045771	8	HEX NUT M8
23	086719	1	PAN, BELLY	65	038353	3	VIBRATION MOUNT
24	0C3296	1	FRAME	67	079119	2	TAPTITE 1/4"-20 x 1-1/4"
25	090141A	1	GROUND STRAP	68	0A7213	2	TAG, REMOVE BOLT
26	086724	1	PLATE, BASE COVER	69	023897	6	FLAT WASHER #10-M5
27	090475	1	PUMP, FUEL	70	0A9172	1	BRACKET, IGNITION SYSTEM
28	028740	1	BARBED 90 1/8" x 1/4"	71	089047	2	SPACER, IGNITION COIL
29	022127	3	HEX NUT 1/4"-20	72	086711	1	MODULE, IGNITION
30	022097	7	LOCK WASHER-1/4"-M6	73	089049B	1	ASSEMBLY, IGNITION COIL
31	086729	1	CONTACTOR, STARTER	74	049721	2	M6-1.0 x 35MM HEX HD. CAPSCREW
32	090518	1	BOOT, CONTACTOR	75	049813	4	M6-1.0 HEX NUT
33	089048	1	SEAL, OIL FILTER HOLE	76	091526	2	M5-0.8 x 12MM-PPHMS
34	090537	1	RETAINER, SEAL	77	051716	2	M5-0.8 HEX NUT
35	022145	4	M8 FLAT WASHER	78	049226	4	LOCK WASHER M5
36	030340	1	1/4" FUEL LINE-4" LONG	79	084867	.5 FT.	RUBBER "U" CHANNEL
37	048031C	5	1/4" HOSE CLAMP	80	056892	1	CRIMPTITE #10-24 x 3/8"
38	023484D	1	SNAP BUSHING	81	0A9196	1	COVER, IGNITION SYSTEM
39	0A8475	4	SPECIAL LOCK WASHER, M5				
40	022471	2	#8 HEX NUT				
41	022264	2	#8 LOCK WASHER				

Section 6 – Exploded Views and Parts Lists

IMPACT-36 plus II Recreational Vehicle Generator
GN 220 RV Long Block – Drawing No. 0A6202-F

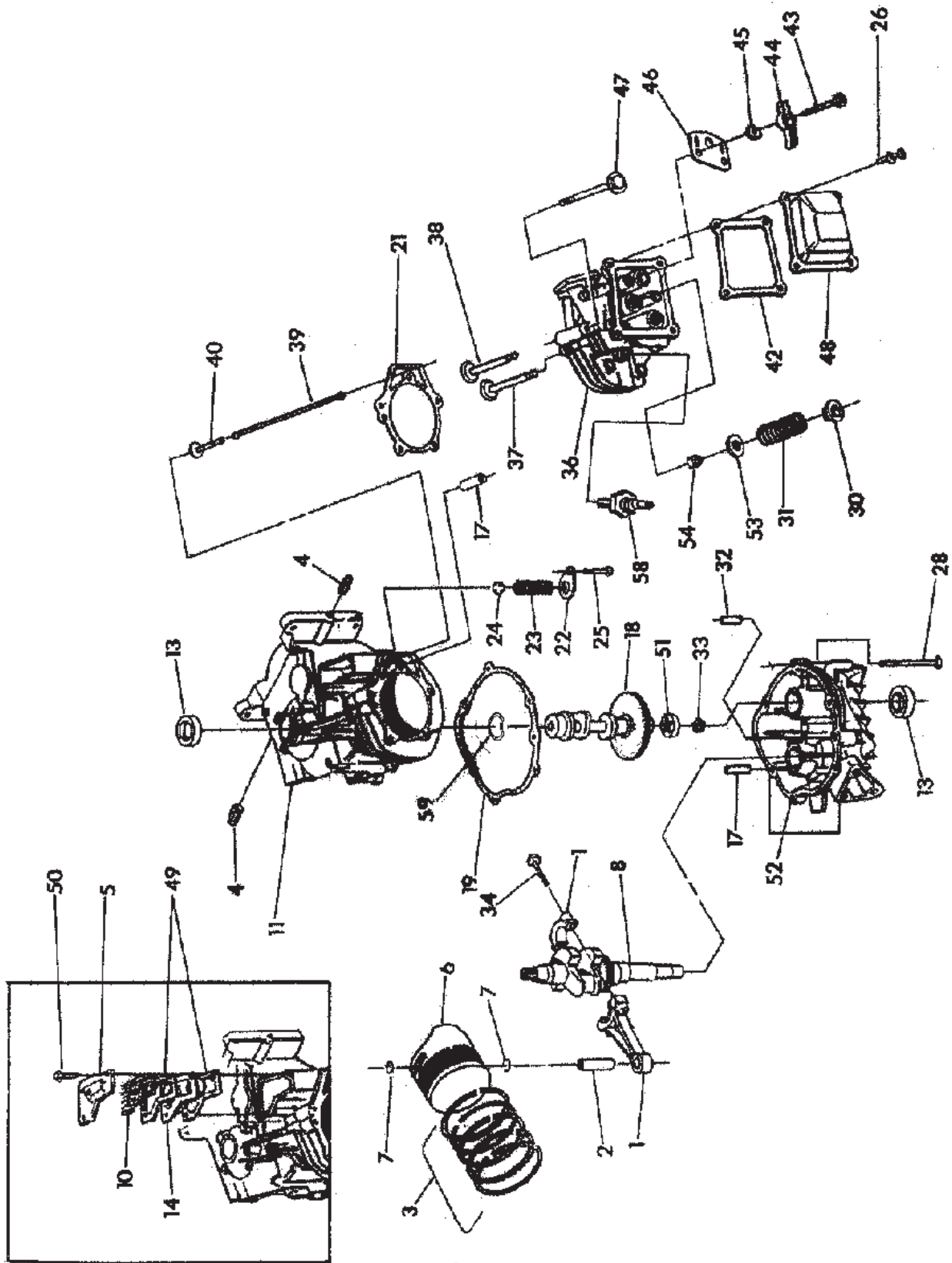

Section 6 – Exploded Views and Parts Lists

IMPACT-36 plus II Recreational Vehicle Generator GN 220 RV Long Block – Drawing No. 0A6202-F

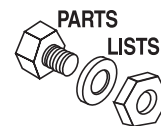

ITEM	PART NO.	QTY.	DESCRIPTION
1	078621	1	ASSEMBLY, CONNECTING ROD & CAP
2	076389	1	PISTON PIN
3	088411	1	PISTON RING SET (STD. SIZE)
4	072657A	2	PIPE PLUG - 1/4 NPT
5	077176	1	COVER, BREATHER
6	088057	1	PISTON, 75 DIA.
7	076390	2	RETAINER, PISTON PIN
8	083379A	1	ASSEMBLY, CRANKSHAFT AND GEAR
10	089923	1	SEPARATOR, OIL-BREATHER
11	089213G	1	ASSEMBLY, CRANKCASE
13	081695	2	SEAL, OIL-CRANKSHAFT
14	090604	1	CUP, BREATHER BAFFLE
17	078699B	3	SLEEVE, DOWEL DIA. 12
18	0A9878	1	ASSEMBLY, CAMSHAFT
19	089096	1	GASKET, CRANKCASE FLANGE
21	0A8822	1	GASKET, CYLINDER HEAD
22	078691	1	RETAINER, OIL PRESSURE SPRING
23	0A5772	1	SPRING, OIL PRESSURE
24	0A5776	1	BALL, OIL PRESSURE
25	074908	1	TAPTITE, M5-0.8 X 10
26	078606	4	SCREW & LOCKWASHER, M6-1.00 X 12MM
28	0D2414	6	SCREW HHFC M8-1.25 X 35
30	0C3733	2	RETAINER, VALVE SPRING
31	088401	2	SPRING VALVE
32	088590	1	DOWEL PIN, DIA. 12 X 18 LONG
33	083152	1	GEROTOR, INNER
34	076381	2	BOLT, CONNECTING ROD
36	021705B	1	ASSEMBLY, CYLINDER HEAD WITH GUIDES & SEATS
37	0C3590	1	VALVE, EXHAUST
38	0C3591	1	VALVE, INTAKE
39	088396A	2	PUSH ROD
40	083235	2	TAPPET
42	0C8754	1	GASKET, VALVE COVER
43	077161	2	STUD, BALL PIVOT
44	077160	2	ROCKER ARM
45	076307	2	NUT, ROCKER ARM
46	088403	1	PLATE, PUSH ROD GUIDE
47	077168	5	HEADBOLT, M8 X 56MM
48	088413B	1	COVER, ROCKER
49	078629	2	GASKET, BREATHER
50	090388	2	BOLT, TAPTITE M6 X 12MM
51	083153	1	GEROTOR, OUTER
52	092977	1	ASSEMBLY - SUMP, OIL
53	084186	2	WASHER, WEAR-VALVE SPRING
54	088156	1	SEAL, VALVE-INTAKE
58	072347	1	SPARK PLUG, CHAMPION RC12YC
59	099922	1	WASHER, WAVE

Section 6 – Exploded Views and Parts Lists
IMPACT-36 plus II Recreational Vehicle Generator
Generator – Drawing No. 0D4945-A

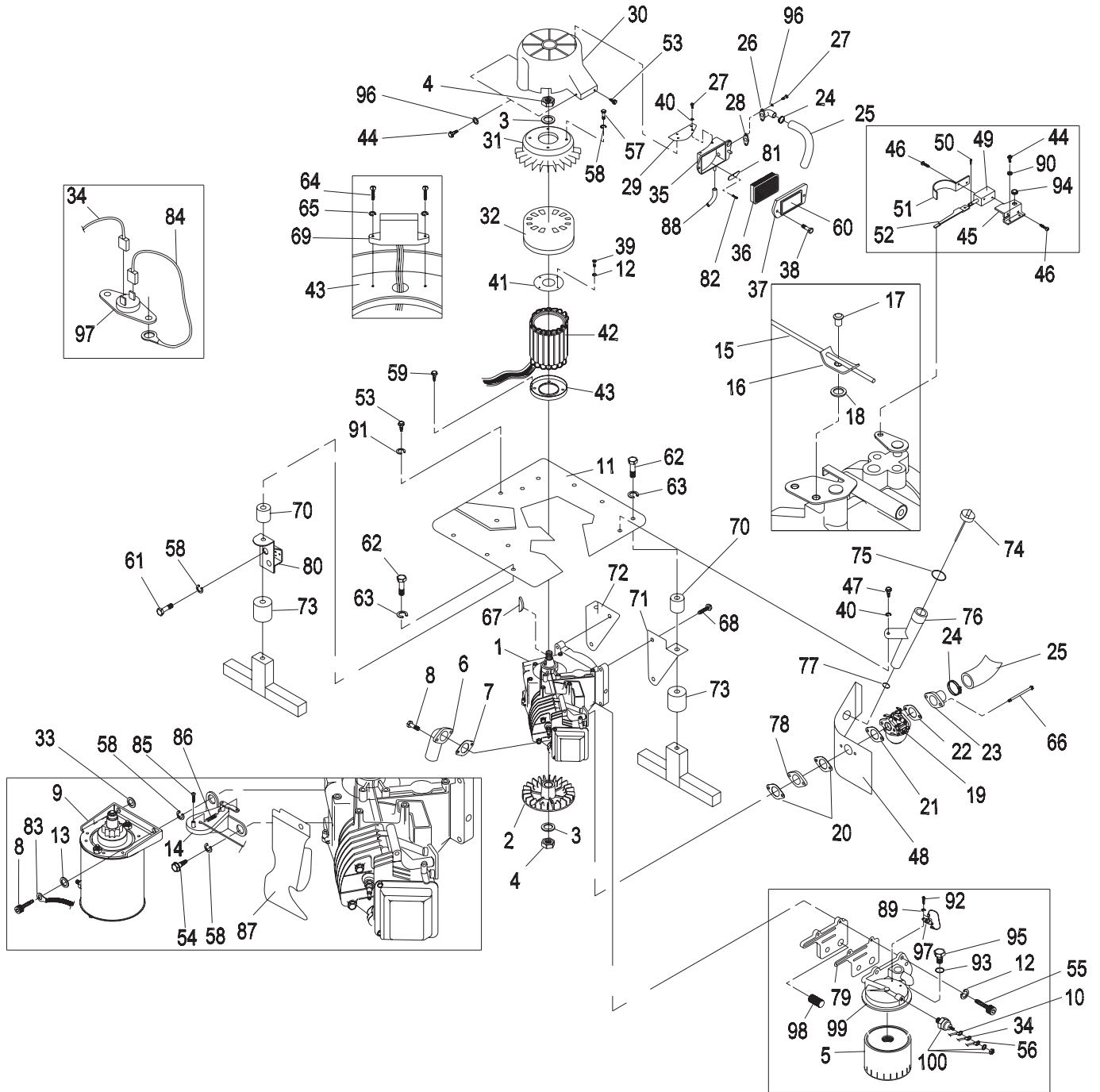

Section 6 – Exploded Views and Parts Lists

IMPACT-36 plus II Recreational Vehicle Generator Generator – Drawing No. 0D4945-A

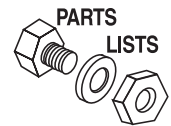

ITEM	PART NO.	QTY.	DESCRIPTION	ITEM	PART NO.	QTY.	DESCRIPTION
1	0A2467	1	ENGINE, LONG BLOCK	54	083512	1	TAPTITE M8-1.25 x 16MM
2	094583	1	FLYWHEEL, FAN	55	097962	4	SHCS, M6-1.0 x 25 LG
3	083312	2	WASHER, CONICAL	56	0912970005	1	OIL PRESSURE SWITCH WIRE
4	081810	2	HEX NUT, M16-1.5	57	042907	3	HEX HD. CAPSCR., M8-1.25 x 16MM
5	070185	1	FILTER, OIL	58	022129	10	LOCK WASHER-M8
6	086730	1	TUBE, EXHAUST OUTLET	59	074906	4	M6-1 x 20MM TAPTITE
7	089476	1	GASKET, EXHAUST	60	0D5259	1	A/C DECAL (940)
8	040976	4	SOCKET HD. CAPSCR., M8-1.25 x 20MM		0D5259A	1	A/C DECAL (941)
9	099948	1	STARTER MOTOR	61	039253	3	HEX HD. CAPSCR., M8-1.25 x 20MM
10	0912970071	1	GROUND WIRE (PRESSURE SWITCH)	62	022511	3	HEX HD. CAPSCR., 3/8"-16 x 1.25"
11	086705	1	PLATE, DIVIDER	63	022237	3	LOCKWASHER-3/8"
12	022097	8	LOCKWASHER, 1/4"-M6	64	055822	2	PHMS, M4-0.7 x 8MM
13	022145	2	WASHER	65	022264	2	LOCK WASHER-M4
14	092059	1	STEPPER MOTOR SPEED CONTROL	66	089050	2	PHILLIPS PAN HD. MACH. SCREW-M6-1 x 90MM
15	086706	1	ROD, THROTTLE CONTROL				
16	089477	1	CLIP, ADJUSTMENT	67	082774	1	WOODRUFF KEY-4 x 19MM
17	089478	1	SNAP, RETAINING	68	059637	4	TAPTITE 3/8"-16 x .75"
18	090192	1	WASHER, CARBURETOR	69	086697	1	ASSEMBLY IGNITION SENSOR
19	090881A	1	CARBURETOR ASSEMBLY (940)	70	086704	3	SPACER, ENGINE MOUNT
	0A2774A	1	CARBURETOR ASSEMBLY (941)	71	086701	1	BRACKET, ENGINE MOUNT FRONT
20	090051	2	GASKET, CARB./SPACER/HEAD	72	086702	1	BRACKET, ENGINE MOUNT REAR
21	078631	1	GASKET, CARBURETOR/SKIRT	73	038353	3	RUBBER MOUNTS
22	096459	1	GASKET, CARB./INLET ADAPTOR	74	089263	1	ASSEMBLY, OIL FILL CAP & DIPSTICK
23	086709	1	ADAPTOR, CARBURETOR INLET	75	090071	1	O-RING, 1.062" I.D.
24	035586	2	HOSE CLAMP-BAND #20	76	094637	1	OIL FILL TUBE
25	086710	1	HOSE, CARBURETOR INLET	77	090072	1	O-RING .562" I.D.
26	087993	1	ELBOW, AIR CLEANER OUTLET	78	086708	1	CARBURETOR SPACER
27	049815	8	HEX HD. CAPSCR., M5-.8 x 16MM	79	087478	1	GASKET, OIL FILTER ADAPTOR
28	090536	1	GASKET, AIR CLEANER OUTLET	80	096627	1	BRACKET, STARTER SIDE ENGINE MNT.
29	090021	1	BRACKET, AIR CLEANER SUPPORT				
30	094665	1	HOUSING, FAN-UPPER	81	090613	1	COVER, BREATHER CANAL
31	093859	1	FAN, GENERATOR	82	059635	1	#8 x 3/8" PLASTITE SCREW
32	0A5892	1	ASSEMBLY, MAGNET HOUSING	83	0912970002	1	STARTER WIRE
33	0D4983	1	WASHER FLAT 10MM ID X 16MM OD	84	0912970004	1	TEMP SWITCH GROUND WIRE
34	0912970003	1	TEMP. SWITCH WIRE	85	059636	1	PLASTITE SCREW, #4 x .37"
35	086673	1	BASE, AIR BOX	86	088905	1	EXTENSION SPRING
36	078601	1	ELEMENT, AIR FILTER	87	092800	1	WRAPPER, ENGINE TOP
37	086674	1	COVER, AIR BOX	88	089062	1	HOSE, BREATHER
38	078609	2	BOLT, AIR CLEANER COVER	89	043182	2	LOCK WASHER-M3
39	066449C	4	HEX HD. CAPSCR., M6-1 x 80MM	90	023762	2	WASHER, EXTERNAL SHAKEPROOF #10 (940)
40	049226	4	LOCK WASHER, M5				
41	080934	1	RETAINING RING, STATOR	91	022447	3	WASHER, INTERNAL SHAKEPROOF, .25"
42	0D4883	1	ASSEMBLY STATOR				
43	086692	1	ADAPTOR. STATOR	92	0C1085	2	PPHMS, M3-0.5 x 8MM
44	074908	3	TAPTITE, M5-0.8 x 10MM	93	0C2908	1	GASKET, OIL DRAIN PLUG
45	086735	1	COVER CHOKE MOUNT (940)	94	023484P	1	SNAP BUSHING (940)
46	0A7094	4	SCREW, #4-40 x .188" (940)	95	052617	1	DRAIN PLUG, M12-1.75 x 20MM
47	056893	1	CRIMPTITE #10-24 x 1/2"	96	023897	6	#10-M5 FLAT WASHER
48	086726	1	SKIRT, BAFFLE	97	094090	1	SWITCH, THERMAL OIL TEMP.
49	091306	1	SOLENOID, CHOKE (940)	98	086714	1	SCREEN, OIL PICK-UP
50	036544	1	P/N, COTTER 3/32" x 1/2" (940)	99	0D2446	1	ADAPTOR, OIL FILTER
51	089473	1	ASSEMBLY, BI-METAL & HEATER (940)	100	0A8584	1	10 PSI OIL PRESSURE SWITCH
52	086736	1	LINKAGE, CHOKE CONTROL (940)				
53	045756	3	M6-1 x 10MM TAPTITE				



Section 7 – Warranty

IMPACT-36 plus II Recreational Vehicle Generator

CALIFORNIA AND FEDERAL EMISSION CONTROL WARRANTY STATEMENT

YOUR WARRANTY RIGHTS AND OBLIGATIONS

The California Air Resources Board (CARB) and the United States Environmental Protection Agency (EPA), together with Generac Power Systems, Inc. (Generac), are pleased to explain the Emission Control System Warranty on your new engine.* New utility, and lawn and garden equipment engines must be designed, built and equipped to meet stringent anti-smog standards for the state of California and the federal government. Generac will warrant the emission control system on your engine for the periods of time listed below provided there has been no abuse, neglect, unapproved modification or improper maintenance of your engine.

Your emission control system may include parts such as the carburetor, ignition and exhaust systems. Generac will repair your engine at no cost to you for diagnosis, replacement parts and labor, should a warrantable condition occur.

MANUFACTURER'S EMISSION CONTROL SYSTEM WARRANTY COVERAGE:

Emissions control systems on 1997 and later model year engines are warranted for two years as hereinafter noted. If, during such warranty period, any emission-related component or system on your engine is found to be defective in materials or workmanship, repairs or replacement will be performed by a Generac Authorized Warranty Service Facility.

PURCHASER'S/OWNER'S WARRANTY RESPONSIBILITIES:

As the engine purchaser/owner, you are responsible for the completion of all required maintenance as listed in your factory supplied *Owner's Manual*. For warranty purposes, Generac recommends that you retain all receipts covering maintenance on your engine. However, Generac cannot deny warranty solely because of the lack of receipts or for your failure to ensure the completion of all scheduled maintenance.

As the engine purchaser/owner, you should, however, be aware that Generac may deny any and/or all warranty coverage or responsibility if your engine, or a part/component thereof, has failed due to abuse, neglect, improper maintenance or unapproved modifications, or the use of counterfeit and/or "grey market" parts not made, supplied or approved by Generac.

You are responsible for presenting your engine to a Generac Authorized Warranty Service Facility as soon as a problem occurs. The warranty repairs should be completed in a reasonable amount of time, not to exceed 30 days.

Warranty service can be arranged by contacting either your selling dealer or a Generac Authorized Warranty Service Facility. To locate the Generac Authorized Warranty Service Facility nearest you, call our toll-free number:

1-800-333-1322

IMPORTANT NOTE: This warranty statement explains your rights and obligations under the Emission Control System Warranty (ECS Warranty), which is provided to you by Generac pursuant to California and federal law. See also the "Generac Limited Warranties for Generac Power Systems, Inc.," which is enclosed herewith on a separate sheet, also provided to you by Generac. The ECS Warranty applies **only** to the emission control system of your new engine. If there is any conflict in terms between the ECS Warranty and the Generac Warranty, the ECS Warranty shall apply except in circumstances where the Generac Warranty may provide a longer warranty period. Both the ECS Warranty and the Generac Warranty describe important rights and obligations with respect to your new engine.

Warranty service can be performed only by a Generac Authorized Warranty Service Facility. When requesting warranty service, evidence must be presented showing the date of the sale to the original purchaser/owner. The purchaser/owner shall be responsible for any expenses or other charges incurred for service calls and/or transportation of the product to/from the inspection or repair facilities. The purchaser/owner also shall be responsible for any and/or all damages or losses incurred while the engine is being transported/shipped for inspection or warranty repairs.

If you have any questions regarding your warranty rights and responsibilities, you should contact Generac at the following address:

ATTENTION WARRANTY DEPARTMENT
GENERAC POWER SYSTEMS, INC.
P.O. BOX 8
WAUKESHA, WI 53187

Part 1



EMISSION CONTROL SYSTEM WARRANTY

Emission Control System Warranty (ECS Warranty) for 1997 and later model year engines:

- (a) Applicability: This warranty shall apply to 1997 and later model year engines. The ECS Warranty Period shall begin on the date the new engine or equipment is purchased by/delivered to its original, end-use purchaser/owner and shall continue for 24 consecutive months thereafter.
- (b) General Emissions Warranty Coverage: Generac warrants to the original, end-use purchaser/owner of the new engine or equipment, and to each subsequent purchaser/owner, that each of its engines is ...
- (1) Designed, built and equipped so as to conform with all applicable regulations adopted by the EPA and CARB pursuant to their respective authority, and
 - (2) Free from defects in materials and workmanship which, at any time during the ECS Warranty Period, may cause a warranted emissions-related part to fail to be identical in all material respects to the part as described in the engine manufacturer's application for certification.
- (c) The ECS Warranty only pertains to emissions-related parts on your engine, as follows:
- (1) Any warranted, emissions-related parts that are not scheduled for replacement as required maintenance in the *Owner's Manual* shall be warranted for the ECS Warranty Period. If any such part fails during the ECS Warranty Period, it shall be repaired or replaced by Generac according to Subsection (4) below. Any such part repaired or replaced under the ECS Warranty shall be warranted for the remainder of the ECS Warranty Period.
 - (2) Any warranted, emissions-related part that is scheduled only for regular inspection as specified in the *Owner's Manual* shall be warranted for the ECS Warranty Period. A statement in such written instructions to the effect of "repair or replace as necessary" shall not reduce the ECS Warranty Period. Any such part repaired or replaced under the ECS Warranty shall be warranted for the remainder of the ECS Warranty Period.
 - (3) Any warranted, emissions-related part that is scheduled for replacement as required maintenance in the *Owner's Manual* shall be warranted for the period of time prior to the first scheduled replacement point for that part. If the part fails prior to the first scheduled replacement, the part shall be repaired or replaced by Generac according to Subsection (4) below. Any such emissions-related part repaired or replaced under the ECS Warranty shall be warranted for the remainder of the ECS Warranty Period prior to the first scheduled replacement point for such emissions-related part.
 - (4) Repair or replacement of any warranted, emissions-related part under this ECS Warranty shall be performed at no charge to the owner at a Generac Authorized Warranty Service Facility.
 - (5) When the engine is inspected by a Generac Authorized Warranty Service Facility, the owner shall not be held responsible for diagnostic costs if the repair is deemed warrantable.
 - (6) Generac shall be liable for damages to other original engine components or approved modifications proximately caused by a failure under warranty of any emission-related part covered by the ECS Warranty.
 - (7) Throughout the ECS Warranty Period, Generac shall maintain a supply of warranted emission-related parts sufficient to meet the expected demand for such emission-related parts.
 - (8) Any Generac authorized and approved emission-related replacement part may be used in the performance of any ECS Warranty maintenance or repairs and will be provided without charge to the purchaser/owner. Such use shall not reduce Generac's ECS Warranty obligations.
 - (9) Unapproved, add-on, modified, counterfeit and/or "grey market" parts may not be used to modify or repair a Generac engine. Such use voids this ECS Warranty and shall be sufficient grounds for disallowing an ECS Warranty claim. Generac shall not be held liable hereunder for failures of any warranted parts of a Generac engine caused by the use of such an unapproved, add-on, modified, counterfeit and/or "grey market" part.

EMISSION RELATED PARTS INCLUDE THE FOLLOWING:

- | | |
|---|--|
| <ol style="list-style-type: none"> 1) Fuel Metering System: <ol style="list-style-type: none"> 1.1) Gasoline carburetor assembly and its internal components (if so equipped). <ol style="list-style-type: none"> a) Fuel filter (if so equipped) b) Carburetor gaskets c) Fuel pump (if so equipped) 1.2) LPG carburetion assembly and its internal components (if so equipped). <ol style="list-style-type: none"> a) Fuel controller (if so equipped) b) Mixer and its gaskets (if so equipped) c) Carburetor and its gaskets (if so equipped) d) Primary gas regulator (if so equipped) e) LP liquid vaporizer (if so equipped) | <ol style="list-style-type: none"> 2) Air Induction System including: <ol style="list-style-type: none"> a) Intake pipe/manifold b) Air cleaner 3) Ignition System including: <ol style="list-style-type: none"> a) Spark plug b) Ignition module 4) Catalytic Muffler Assembly (if so equipped) including: <ol style="list-style-type: none"> a) Muffler gasket b) Exhaust manifold 5) Crankcase Breather Assembly including: <ol style="list-style-type: none"> a) Breather connection tube |
|---|--|

*Generac engine types covered by this warranty statement include the following:

- 1) Utility
- 2) Lawn and Garden Equipment
- 3) Recreational Vehicle (RV) Generator
- 4) Industrial Mobile (IM) Generator



Section 7 – Warranty

IMPACT-36 plus II Recreational Vehicle Generator

GENERAC POWER SYSTEMS THREE-YEAR LIMITED WARRANTY FOR RECREATIONAL VEHICLE GENERATORS

NOTE: ALL UNITS MUST BE INSTALLED BY GENERAC POWER SYSTEMS AUTHORIZED SERVICE FACILITIES. For a period of 3 (three) years or 2,000 (two thousand) hours of operation from the date of original sale, whichever occurs first, Generac Power Systems, Inc. (Generac) will, at its option, repair or replace any part which, upon examination, inspection and testing by Generac or a Generac Authorized Warranty Service Dealer, is found to be defective under normal use and service, in accordance with the warranty schedule set forth below. Any equipment that the purchaser/owner claims to be defective must be returned to and examined by the nearest Generac Authorized Warranty Service Dealer. All transportation costs under the warranty, including return to the factory, are to be borne and prepaid by the purchaser/owner. This warranty applies only to Generac generators sold and rated for "Recreational Vehicle" (RV) applications, as Generac has defined Recreational Vehicle generator applications.

WARRANTY SCHEDULE – COMMERCIAL APPLICATIONS

YEAR ONE – 100% (one hundred percent) coverage on part(s), labor, removal and reinstallation listed:

- **Engine** – All components
- **Alternator** – All components

WARRANTY SCHEDULE – CONSUMER/PERSONAL APPLICATIONS

YEARS ONE AND TWO – 100% (one hundred percent) coverage on part(s), labor, removal and reinstallation listed:

- **Engine** – All components
- **Alternator** – All components

YEAR Three – 100% (one hundred percent) only on selected part(s) and labor listed (**Any labor and part(s) not listed, and removal and reinstallation are the owner's responsibility**):

- Rotor, Stator, IMPACT™ Series Variable Speed Computer Control Board Part Numbers A3369, A6060, Cylinder Block, Cylinder Head, Crankshaft, Piston(s), Valve, Valve Lifter(s), Intake and Exhaust Manifolds

FOR THE LIFE OF THE RECREATIONAL VEHICLE GENERATOR (IF SO EQUIPPED)

The drive train belt and pulleys (if so equipped) on generators used in recreational vehicles shall be warranted against failure due to defective materials or normal usage for the life of the generator. For the original purchaser/owner, this drive train warranty shall include part(s) and labor (removal and reinstallation are not included) plus \$50 (fifty dollars – U.S.) payment upon return of the failed belt or pulley by the original purchaser/owner. For subsequent purchaser/owner, this drive train warranty shall cover belt and pulley part(s) **ONLY** (labor not included). Labor, removal and reinstallation is the responsibility of the subsequent purchaser/owner.

Generac RV generators manufactured prior to December 31, 1997, **DO NOT** have a transferable warranty. Generac RV generators manufactured after January 1, 1998, have a transferable warranty to the second owner **ONLY** for the remainder of the three-year limited warranty. Proof-of-purchase is required and must be presented to a Generac Authorized Warranty Service Dealer prior to the performance of any warranty service.

All warranty expense allowances **are** subject to the conditions defined in Generac's WARRANTY POLICY AND PROCEDURES MANUAL.

THIS WARRANTY SHALL NOT APPLY TO THE FOLLOWING:

- Generac RV generators that utilize non-Generac replacement parts.
- Costs of normal maintenance, adjustments, installation and start-up.
- Failures caused by any contaminated fuels, oils, coolants or lack of proper fluid amounts.
- Failures due, but not limited, to normal wear and tear, accident, misuse, abuse, negligence or improper installation. As with all mechanical devices, the Generac engines need periodic part(s) service and replacement to perform well. This warranty will not cover repair when normal use has exhausted the life of a part(s) or engine.
- Failures caused by any external cause or act of God, such as collision, theft, vandalism, riot or wars, nuclear holocaust, fire, freezing, lightning, earthquake, windstorm, hail, volcanic eruption, water or flood, tornado or hurricane.
- Damage related to rodent infestation.
- Products that are modified or altered in a manner not authorized by Generac in writing.
- Any incidental, consequential or indirect damages caused by defects in materials or workmanship, or any delay in repair or replacement of the defective part(s).
- Failure due to misapplication.
- Telephone, cellular phone, facsimile, internet access or other communication expenses.
- Living or travel expenses of person(s) performing service, except as specifically included within the terms of a specific unit warranty period.
- Expenses related to "customer instruction" or troubleshooting where no manufacturing defect is found.
- Rental equipment used while warranty repairs are being performed.
- Overnight freight costs for replacement part(s).
- Overtime labor.
- Starting batteries, fuses, light bulbs and engine fluids.

THIS WARRANTY IS IN PLACE OF ALL OTHER WARRANTIES, EXPRESSED OR IMPLIED. SPECIFICALLY, GENERAC MAKES NO OTHER WARRANTIES AS TO THE MERCHANTABILITY OR FITNESS FOR A PARTICULAR PURPOSE. Some states do not allow limitations on how long an implied warranty lasts, so the above limitation may not apply to you.

GENERAC'S ONLY LIABILITY SHALL BE THE REPAIR OR REPLACEMENT OF PART(S) AS STATED ABOVE. IN NO EVENT SHALL GENERAC BE LIABLE FOR ANY INCIDENTAL OR CONSEQUENTIAL DAMAGES, EVEN IF SUCH DAMAGES ARE A DIRECT RESULT OF GENERAC'S NEGLIGENCE. Some states do not allow the exclusion or limitation of incidental or consequential damages, so the above limitation may not apply to you.

This warranty gives you specific legal rights. You also may have other rights that vary from state to state.

GENERAC® POWER SYSTEMS, INC.

P.O. BOX 297

WHITEWATER, WI 53190

Revised 10/05/01