CONCERTO®

ELECTRIC FLUSH, GRAVITY DISCHARGE TOILET

OWNER'S MANUAL



3300 Series
(with flush handle)



3400 Series
(with remote flush switch)

! WARNING

This manual must be read and understood before installation, adjustment, service, or maintenance is performed. Modification of this product can result in property damage.

 **Dometic®**



Dometic Corporation • Sanitation Systems
13128 State Rt 226, PO Box 38
Big Prairie, OH 44611
SeaLand Product Customer Service: 1-800-321-9886
(8:00 a.m. - 5:00 p.m. ET)

TABLE OF CONTENTS

Toilet Model Identification	2	Proper Cleaning and Maintenance	10
Ordering Parts	2	Manual Flush Operation	10
Concerto Toilet Dimensions	3	Winterizing	11
Toilet Installation Instructions	3 - 6	Spare Parts	11
Remote Flush Switch Installation	7	Deodorants and Special Tissue	11
Important Information Before Operation	8	Flush Mechanism Components	12
Electronic "Flush and Forget" Operation	8	Electrical Specifications	13
Toilet Controls	8	Troubleshooting	14 - 17
Operating Instructions	9	Wiring Diagrams	18
Automatic Flush Operation Timing Chart	9	Customer Service	19
		Limited Warranties	20



WARNING – ELECTRICAL SYSTEM.
Turn off electrical power before servicing.



WARNING – MOTOR STARTS AUTOMATICALLY.
Turn off electrical power before servicing.

Read and understand the complete contents of this manual before operating or servicing the toilet. Failure to follow these precautions may result in damage to the toilet.

TOILET MODEL IDENTIFICATION

The model identification label is located on the inside wall of the toilet under the access cover. It will show the model number and serial number.

DOMETIC CORPORATION

P.O. BOX 38, 13128 STATE RT 226 (800) 321-9886
BIG PRAIRIE, OH 44611 USA

MODEL NO. **000**
SERIAL NUMBER

000000

ORDERING PARTS

Dometic is ready to assist you in the event service is required. Before calling, please have the following information available. Your cooperation in having this information ready is appreciated and allows us to better meet your needs. Please refer to the Parts Distributor list in the Customer Service section.

1. Toilet Model Number
2. Serial Number
3. Part Number, Description and Quantity (see Parts List)

Concerto, SeaLand and Flush and Forget are registered trademarks of
Dometic Corporation.

CONCERTO™ TOILET DIMENSIONS

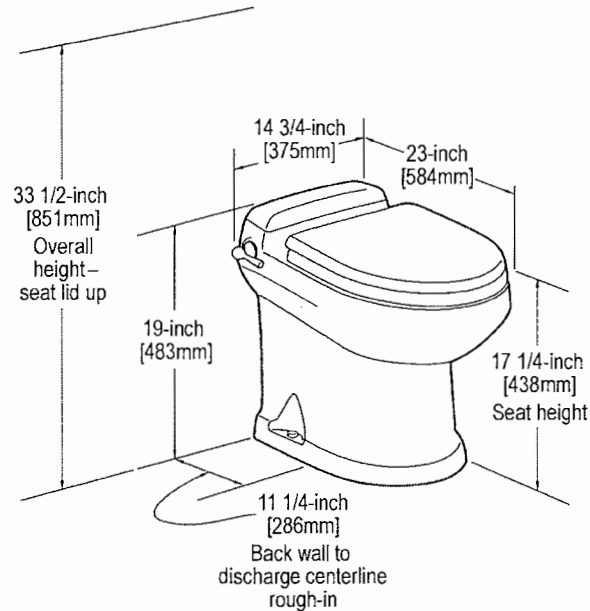

TOILET INSTALLATION INSTRUCTIONS

System Requirements:

- 2 GPM (10.6 lpm) or larger water pump.
- 1/2-inch (12.7 mm) water line terminating in 1/2-inch MPT fitting (to connect to toilet water supply hose).
- 4-bolt floor (closet) flange. SeaLand flanges available include 3-inch spigot, socket, MPT, or 45-degree swivel socket.
- 12 VDC through 7- or 8-amp fuse or circuit breaker. Use 14-gauge stranded copper wire.

IMPORTANT: If replacing an existing gravity-discharge toilet, make sure the center of the existing discharge flange is at least 11-1/4 inches from the back wall, then proceed to Step 5 for proper positioning of water line and electrical wiring.

STEP 1: Carefully unpack the toilet bowl, rear access lid and floor flange adapter. **CAUTION: HANDLE THE VITREOUS CHINA TOILET AND ACCESS LID WITH CARE. SET THE LID IN AN AREA WHERE IT CANNOT BE BROKEN. PLACE LID ON TOILET ONLY AFTER TOILET INSTALLATION IS COMPLETE.**

STEP 2: Position the china bowl in the space intended. Confirm that adequate clearance is available for using the flush handle and opening the seat and lid.

STEP 3: Mark the floor at the rear corners of the toilet bowl (fig. 1). Measure the distance between the two marks and divide by 2 to find the toilet centerline. Mark the floor at the rear wall for the centerline.

STEP 4: Place a carpenter's square against the back wall, and draw a center line on the floor at least 14 inches (356 mm) long (fig. 2). Mark the centerline for the floor flange at 11-1/4 inches (286 mm) from the wall (fig. 3).

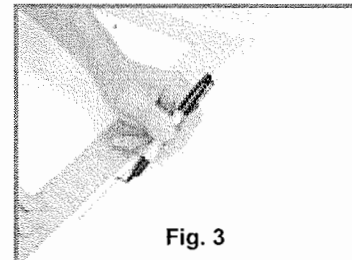
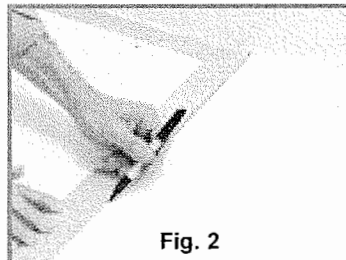
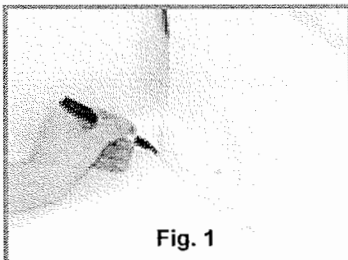

STEP 5a: For through-the-floor water line and electrical wires, mark another centerline 6 inches (152 mm) from the back wall (fig. 4).

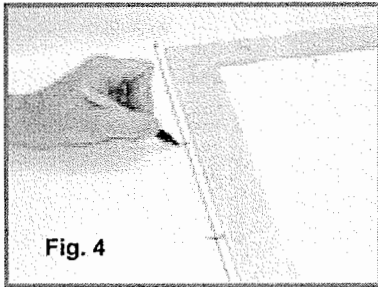

STEP 5b: For through-the-wall water line and electrical wires, mark a centerline 8 inches (203 mm) up from the floor centerline (fig. 5).

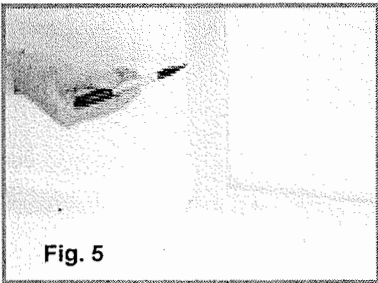

STEP 6: Make a 4-3/4 inch (121 mm) diameter hole (for most floor flanges) or a 5-1/8 inch (130 mm) diameter hole (for swivel joint floor flange) at the centerline mark furthest from the wall. Make a 1 inch (25 mm) hole at the mark closer to the wall for the water line and electrical wires (fig. 6).

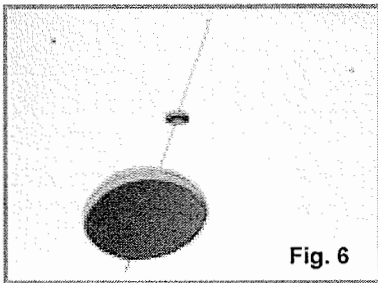

IMPORTANT: The preferred floor flange installation method is to mount the floor flange directly on the finished floor. However, if the bottom of floor flange and bottom of china toilet must be mounted at different heights, the floor flange must be mounted within 3/8 inch (10 mm) of the bottom of the toilet (see illustrations in next column) or leakage may result.

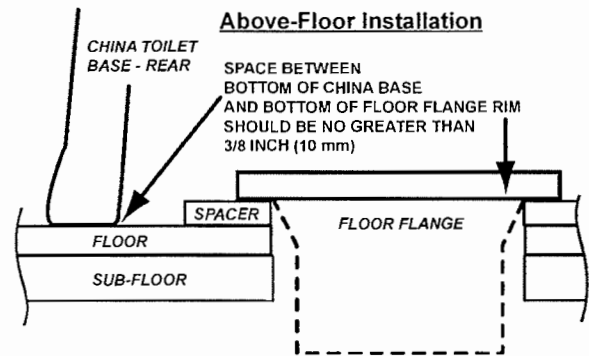
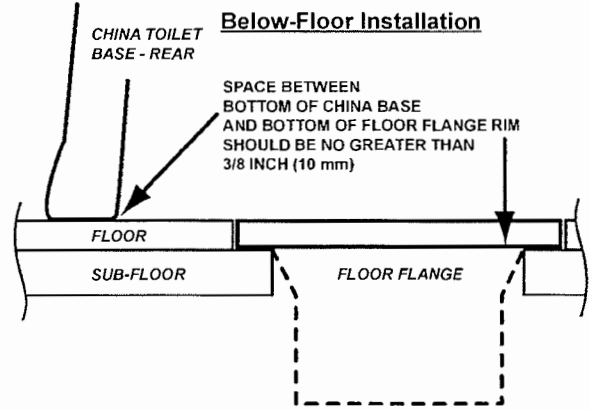

STEP 7: Insert floor flange into larger hole and secure to the floor with #12x3/4-inch long flat head wood or sheet metal screws (fig.7).

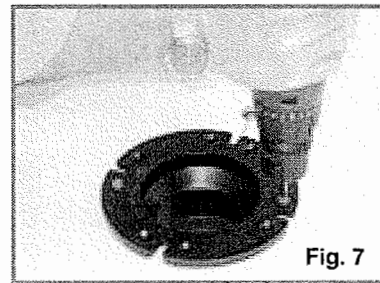

STEP 8: Route 1/2-inch (13mm) PEX tubing through the smaller hole and install a PEX 1/2-inch MPT fitting (fig. 8).

NOTE: A water shut-off valve should be installed in the water line to the toilet for maintenance requirements.

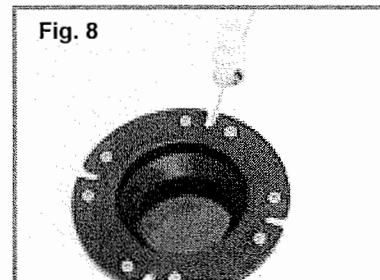

FOR MODEL 3400 TOILET WITH REMOTE SWITCH OPERATION, see page 7 for wall switch installation instructions.

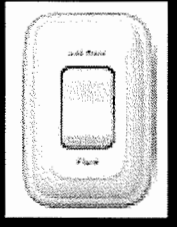

STEP 9: WITH THE ELECTRICAL POWER OFF, route #14 gauge stranded copper wire from 12 VDC ground and positive 12 VDC from the fuse panel through a 7- or 8-amp fuse or circuit breaker. Leave at least 30 inches (305 mm) of wire for connecting to toilet (fig. 9).

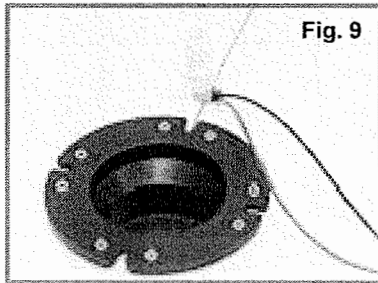

STEP 10: Connect the holding tank to the bottom of the discharge flange.

STEP 11: Slide the four T-bolts into the slots of the floor flange. Install the flange gasket over the T-bolts (fig. 10).

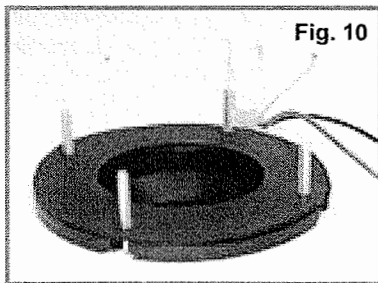

STEP 12: Install floor flange adapter with words "THIS SIDE UP" facing up. Tighten adapter to floor flange using four flat washers and hex nuts. Tighten in criss-cross pattern (fig. 11).

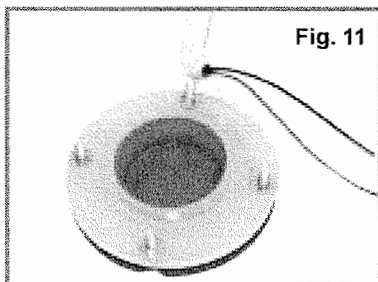

IMPORTANT: If replacing an existing toilet that uses a 2-bolt floor flange, drill two 5/16-inch dia. holes in old floor flange that align with two additional holes in floor flange adapter. Use two #10 or 12 x 1-1/2-inch wood screws and washers for these drilled holes, and two T-bolts with flat washers and nuts to fasten flange gasket and floor flange adapter to old floor flange. Do not use old hardware or seal.

STEP 13: Temporarily set the toilet in place on the floor flange (fig. 14).

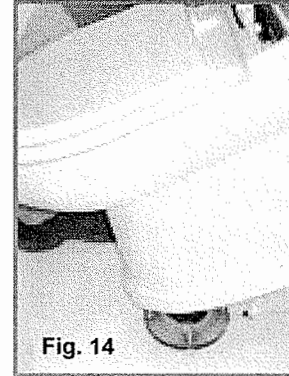

STEP 14: Mark the holes for the two toilet mounting bolts (fig. 15).

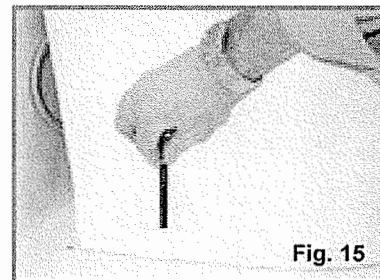

STEP 15: Pick up toilet and set aside. Drill 3/16-inch pilot holes in the floor (fig. 16).

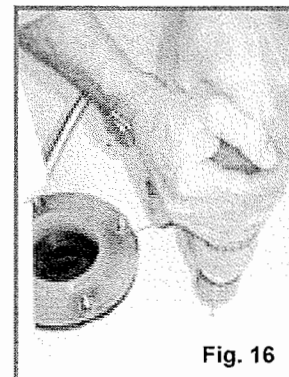

STEP 16: With toilet close to floor flange, connect flexible water supply hose to the water line fitting (fig. 17).

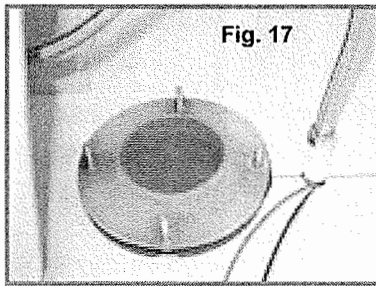

STEP 17: Insert the **positive (+)** 12 VDC wire into position 1 of the green terminal block and tighten the screw securely. Insert the **negative (-)** 12 VDC wire into position 2 of the green terminal block and tighten the screw securely (fig. 18).

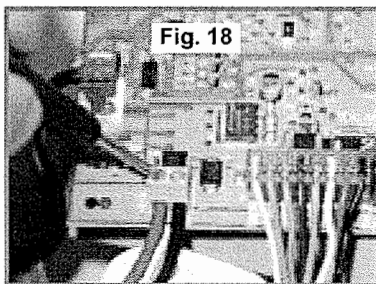

STEP 18: **REMOVE RED CAP FROM MIDDLE OF FLANGE ADAPTER BEFORE FINAL TOILET INSTALLATION.**

IMPORTANT – DO NOT ATTEMPT TO SLIDE THE TOILET OVER THE FLANGE ADAPTER. THE TOILET MUST BE SET DOWN OVER THE ADAPTER TO PREVENT POSSIBLE DAMAGE.

STEP 19: Set the toilet in place (fig. 19) and secure to floor with the #14x2-1/2 inch long lag bolts (fig. 20). Install decorative bolt caps by pushing them onto bolt heads (fig. 21).

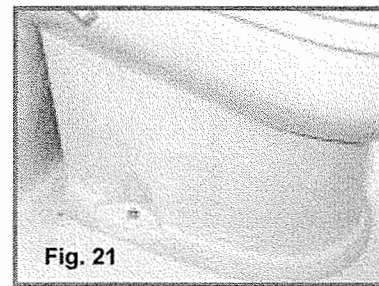
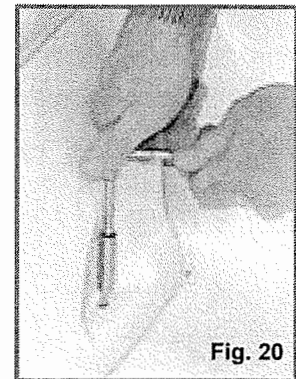
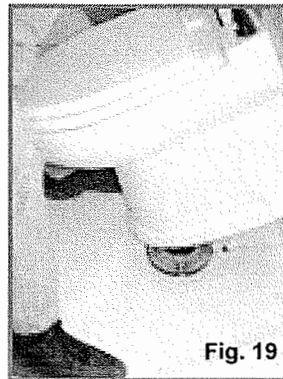

STEP 20: Place the rear access cover on the back of the toilet. Press down firmly to seat the fastening strips.

STEP 21: Turn on electrical power and water to toilet. Lift flush handle and fill toilet bowl with water. Wait one hour, then inspect the floor around and under the rear of the toilet for leaks or dampness.

If no leaks are present, toilet is ready for operation.

MODEL 3400 REMOTE FLUSH SWITCH INSTALLATION

3400 series toilets feature a remote flush switch to control the “Flush” and “Add Water” functions. Follow the instructions below for switch installation.

STEP 1: Select a location for the switch. 8 feet of cable (2.4 m) is provided. You may need to supply more wire, depending on how far you locate the switch from the toilet.

STEP 2: Cut an opening 1-1/4” wide x 1-5/8” high (see diagram at right).

STEP 3: If installing the switch in a shallow wall, you may need to use the spacer between the wall and the switch assembly cover to allow space for the wire connectors. If so, route the cable through the spacer before proceeding to the next step.

STEP 4: Route the 3-conductor cable through wall cut-out and on to toilet. Cable can be routed with water supply line and power wires (see page 5, Step 9). Leave a minimum of 30 inches (.76m) of cable to allow easy wiring at toilet.

STEP 5: Fasten the switch assembly to the wall with the #6x1” screws (included), making sure to install with the label “THIS SIDE UP” on top. Otherwise, the “Flush” and “Add Water” functions will be reversed.

STEP 6: Snap cover onto switch assembly to complete switch installation on wall.

STEP 7: **WITH THE ELECTRICAL POWER OFF**, connect the red, black and white wires from the switch to the red, black and white wires connected to the 11, 12 and 13 terminals on the control module. See page 6, Step 17 for other wiring procedure.

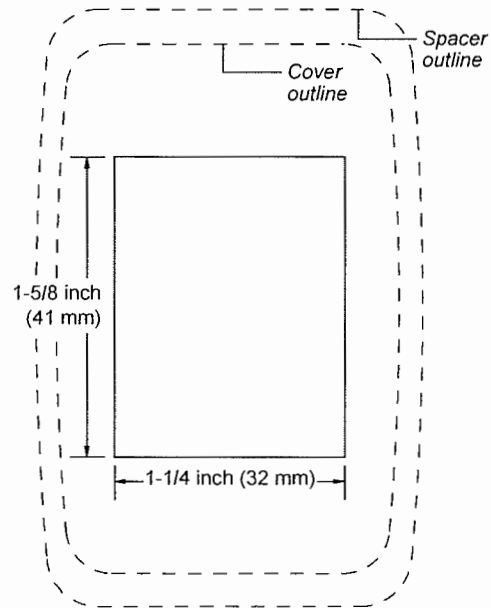

REMOTE FLUSH SWITCH COMPONENTS

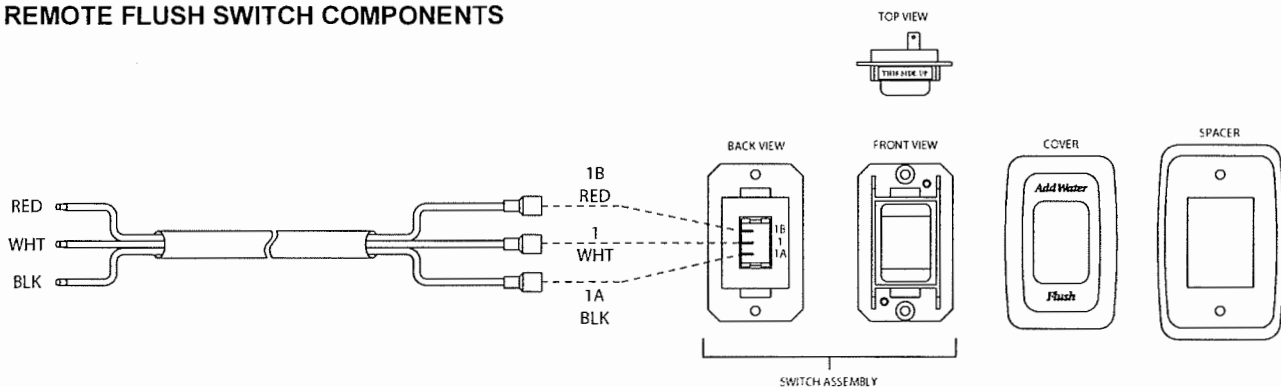

IMPORTANT INFORMATION BEFORE OPERATION

1. Fill freshwater tank and add deodorant to holding tank through toilet bowl.
2. Make sure all guests understand the operation of the toilet system. **3300 models:** This flushing instruction label is located under the seat, and is easily read when the seat is raised. **3400 models:** "Add Water" and "Flush" are clearly marked on the remote switch.
3. Shut off the toilet system before servicing and do not leave the vehicle with toilet system circuit breaker on.
4. **Never use drain openers, alcohol, solvents, etc. in the toilet.**
5. If the toilet does not function properly, refer to the Troubleshooting section of this manual and repair as necessary. If problem persists, contact your local SeaLand product dealer or see the Customer Service section of this manual.

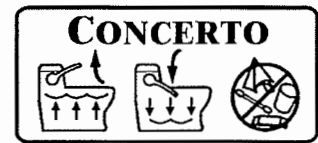

ELECTRONIC FLUSH AND FORGET® OPERATION

FLUSH HANDLE TOILET

1. To add water to the toilet before using (if necessary), raise flush handle until desired water level is reached. (Water flow will stop automatically after a pre-programmed period of time).

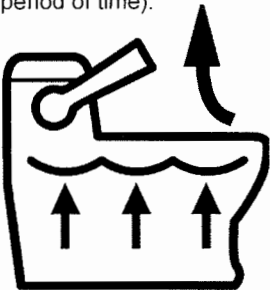

2. To flush toilet, press flush handle down. Water will flow into bowl for two seconds, then flush ball will open. Toilet will not flush again until water refill cycle is complete.

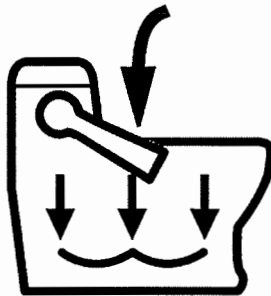

REMOTE FLUSH SWITCH TOILET

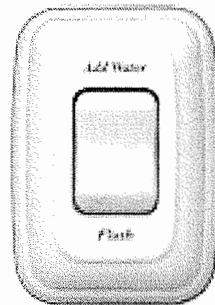

1. To add water to bowl, press top part of switch.
2. To flush, press bottom part of switch.

DO NOT FLUSH FOREIGN OBJECTS THROUGH TOILET



Do not dispose of sanitary napkins or other non-dissolving items in toilet, such as facial tissue or paper towels. These items can cause plugging of the system.

TOILET CONTROLS

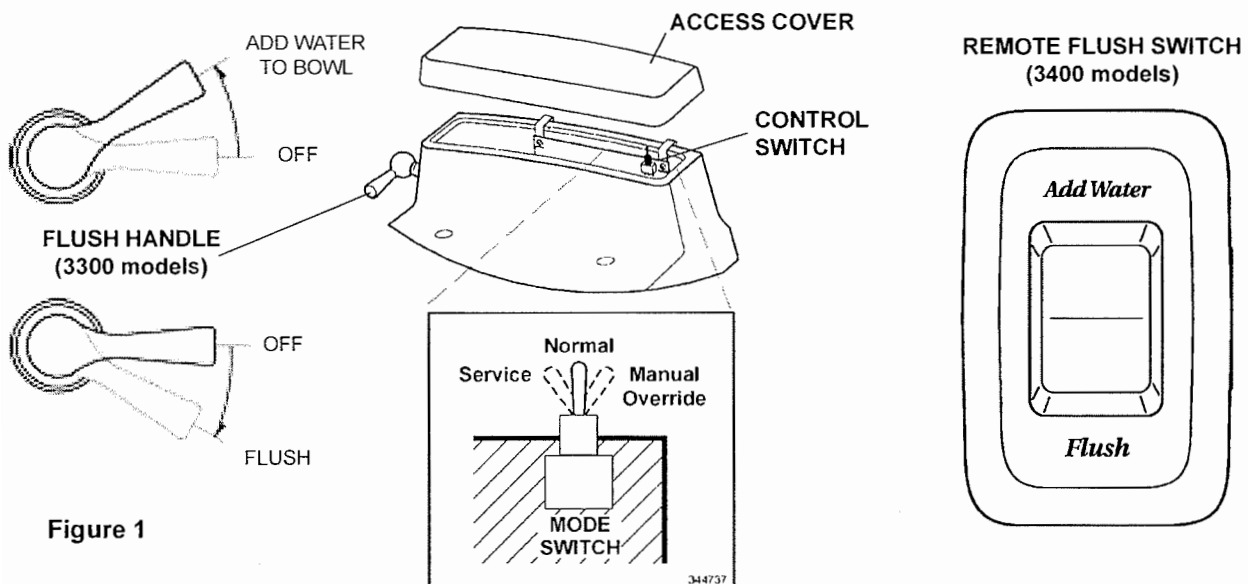

Figure 1

OPERATING INSTRUCTIONS

1. Adding More Water To Toilet Bowl

Pull up the flush handle (3300 model) or push "Add Water" switch (3400 model) until the desired water level is attained. To prevent overflowing the toilet, a timer inside the control module limits the amount of water that can be added.

2. Flushing The Toilet

Push the flush handle down (3300 model) or push "Flush" switch (3400 model) for a moment, then release it. Holding the handle or switch down will not prolong the flush cycle nor start a new flush cycle. The handle or switch must be allowed to return to the neutral position before another flush can occur.

3. Mode Switch

The Mode switch is located on the right side of the control module. It lets you switch between three function settings:

NORMAL

Use this setting for flushing the toilet.

SERVICE

Use this position for cleaning the toilet bowl and flush ball seal. The flush ball will open automatically and remain open in this position. Lifting up the flush handle or pushing the "Add Water" switch provides water to the bowl.

MANUAL OVERRIDE

Use this position to flush the toilet manually in the event of power or battery failure. This switch disconnects the electronic brake in the flush valve motor, and allows manual flushing via the override access hole in the side of the vitreous china base.

Note: The control module allows 15 seconds of water flow for cleaning. If more water is required, return the switch to the NORMAL position, then back to the SERVICE position.

A safety circuit in the control module monitors flush ball operation. If foreign objects or low voltage prevent the flush ball from closing, this circuit prevents personal injury or damage to the flush valve motor. If this condition occurs, reset the control module by placing the Mode switch into the SERVICE position temporarily, then returning it to the NORMAL position.

AUTOMATIC FLUSH OPERATION TIMING CHART

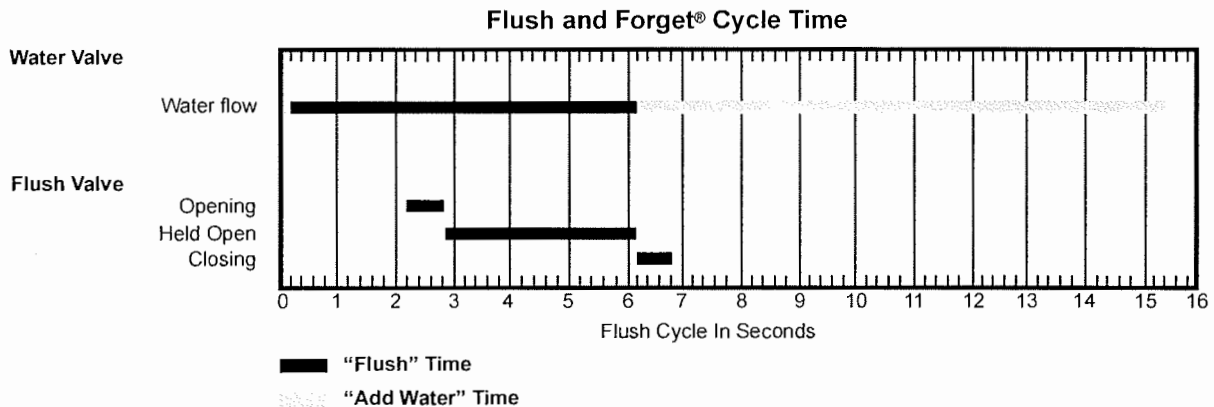

PROPER CLEANING AND MAINTENANCE

The Concerto toilet should be cleaned regularly for maximum sanitation and operational efficiency. You can clean it just as you would a household toilet. **Do not use caustic chemicals, such as drain-opening types, as they will damage the seals.**

BOWL CLEANING: For stubborn stains, use SeaLand Bowl and Seal Cleaner (Fig. A). It's manufactured especially for use with SeaLand toilets. In certain locations where water is hard, a build-up of lime may dull the toilet bowl finish. Restore the shine with this cleaner. If you cannot find our brand in your area, contact SeaLand Product Customer Service for your nearest dealer. If it is not available, you can also use Bar Keepers Friend® cleanser. It is not necessary to vigorously scrub with either product. Please follow label instructions.

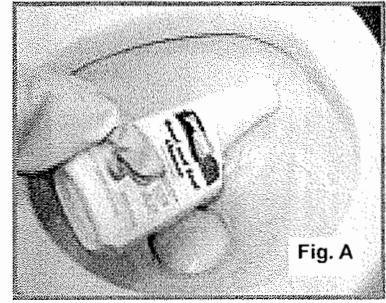

SEAL CLEANING: After an extended time, mineral deposits from hard water can build up under the edge of the rubber bowl seal, resulting in a slow leakdown of water from the bowl. To prevent this mineral build-up, periodically clean under the bowl seal with SeaLand Bowl and Seal Cleaner (Fig. B).

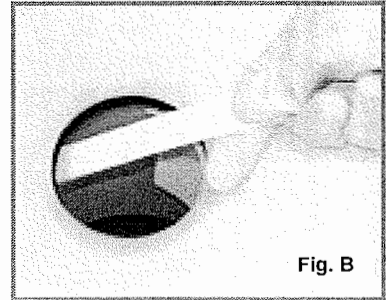

1. Put Mode switch in SERVICE position. Flush ball will open automatically.
2. Apply cleanser onto the seal cleaning tool (supplied with new toilet), and scrub under seal. Make sure to push bristles between bottom of seal and top of flush ball surface to scrub all parts of seal that come into contact with flush ball.
3. Wait 2-3 minutes.
4. Pull up on flush handle or push "Add Water" switch to let water flow into bowl. Use cleaning tool and water to rinse away cleanser and loosened deposits. You can add water for up to 15 seconds in the SERVICE position.
5. Put Mode switch in NORMAL position. Water will flow for a few seconds, then flush ball will close automatically. Water will continue flowing into bowl, making it ready for the next flush.

MANUAL FLUSH OPERATION

In the event of an electrical failure, the flush ball of the toilet can be manually opened to clear the bowl. We recommend using a long-neck screwdriver or 7/16-in. socket for the operation shown below. **NEVER PRY OPEN THE FLUSH BALL FROM INSIDE THE TOILET BOWL.** Damage to the flush ball and bowl seals may result.

1. Remove access cover from top of china toilet. Place Mode Switch in the "Manual Override" position. This disconnects flush valve motor brake from electrical circuit.
3. Insert screwdriver or 7/16-in. socket through access hole and onto hex head.

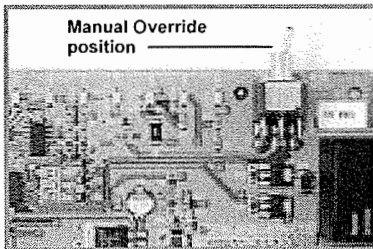

2. Locate hole on side of china toilet. This allows access to the flush valve motor drive arm.

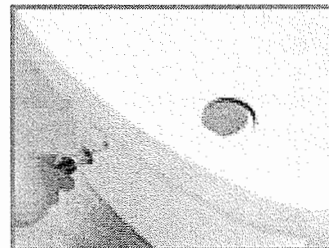
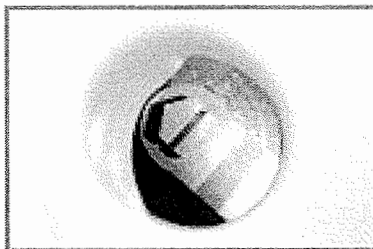

4. Turn screwdriver or socket **counter-clockwise**. This will open flush ball and allow bowl contents to clear. After bowl is clear, turn screwdriver or socket clockwise to return flush ball to original position.

NOTES:

Water will not enter the toilet bowl during manual flush operation.

Place Mode Switch in the "Normal" position before returning to automatic operation.

WINTERIZING

At the end of each traveling season, the Concerto toilet system must be winterized for storage. The following procedure should be used:

1. Pump out waste holding tank.
2. Thoroughly flush toilet system with fresh water.
3. Drain freshwater tank.
4. Add freshwater antifreeze to freshwater tank.
5. Flush freshwater antifreeze and water mixture through toilet and into the waste holding tank. Each installation is different so amounts may vary. User discretion is required to assure adequate protection.
6. Turn off electrical power.

CAUTION: The use of freshwater antifreeze that contains alcohol will result in damage to your sanitation system. Only use propylene glycol freshwater antifreeze that **does not contain alcohol**.

SPARE PARTS

It is recommended that the following spare parts be kept available at all times:

Description	Part Number	Quantity	Description	Part Number	Quantity
Flush Ball Seal Kit	see parts list	1	Water Valve	see parts list	1
Flush Ball	see parts list	1	Vacuum Breaker Assembly	see parts list	1

DEODORANTS AND SPECIAL TISSUE

Your Concerto toilet requires the regular addition of a deodorant product to reduce malodors and to help break down holding tank contents. Several factors should be considered in selecting a deodorant product.

Liquid or Dry: Liquid products obviously work more quickly by readily going into solution. Granulated powder formulations, on the other hand, have the advantage of requiring less storage space and are less likely to leak if the package is inadvertently damaged.

Formaldehyde versus Non-Formaldehyde: Dometic manufactures both types of deodorants. Generally speaking, formaldehyde formulas control odor very effectively at all temperatures and with all degrees of water hardness. SeaLand® Environment-Friendly brand, which is formaldehyde free, is similarly effective.

How Much Deodorant and How to Add It: The deodorant is added directly into the toilet bowl, then flushed into the holding tank. Follow bottle or package instructions. Conditions of extremely warm weather, longer waste holding time and larger tank capacities may require more deodorant treatment. Also, to maintain optimum efficiency in odor control, the waste holding tank should be cleaned thoroughly at least once or more each season, depending on use.

Why Not Use Household Toilet Paper in Your Concerto Toilet? Household tissues often contain adhesives which bond together the paper fibers from which the tissue is made. The adhesives prevent the tissue from breaking apart, and their use in "ultra-low flow" systems can cause system clogging. SeaLand tissue is especially designed for use in low water toilet systems. Its rapid dissolving properties minimize the amount of residual paper in the holding tank and allow deodorizers to work more efficiently.

SeaLand versus Other Brands: SeaLand constantly strives to provide our system owners with effective products that have minimal environmental impact and good value. Many deodorant products do not measure up to our standards of performance and value.

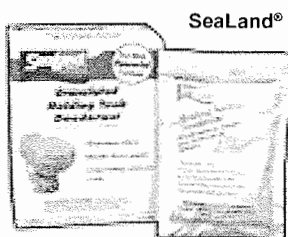

SeaLand® Granulated Deodorant
Six 2-oz. pouches
Part No. 379626002



SeaLand® Liquid Deodorant
Two 8-oz. bottles
Part No. 379224008

SeaLand® Liquid Deodorant - Environment Friendly
32-oz. bottle
Part No. 379114032



SeaLand® Rapid-Dissolving Toilet Tissue
Four 400-sheet rolls
Part No. 379441204



FLUSH MECHANISM COMPONENTS

1. To access base assembly components, remove decorative screw caps and unscrew two bolts that hold china toilet to floor.

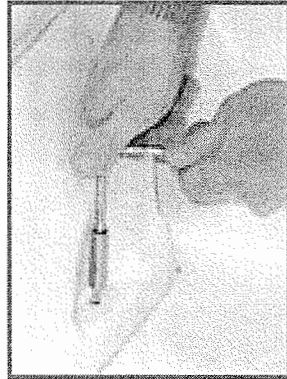

2. Remove access cover from top of china and set it aside.

3. Lift china toilet straight up from base and set it down just in front of floor flange. Turn off water to toilet and disconnect flexible water line. Disconnect power wires and/or flush switch wires if necessary.



FLUSH HANDLE COMPONENTS (3300 series)

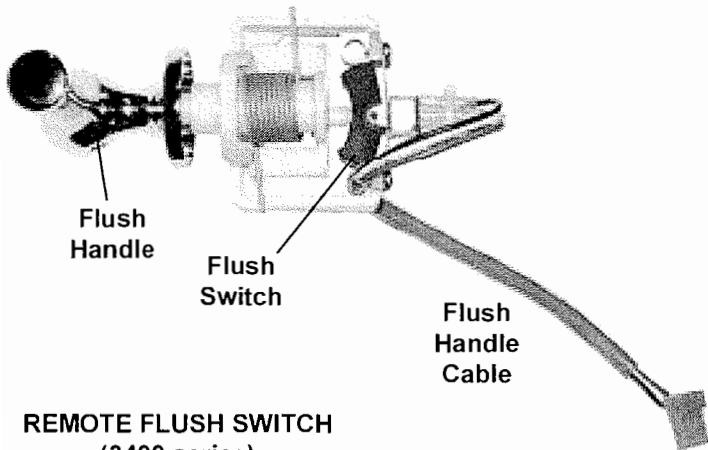

CONTROL MODULE

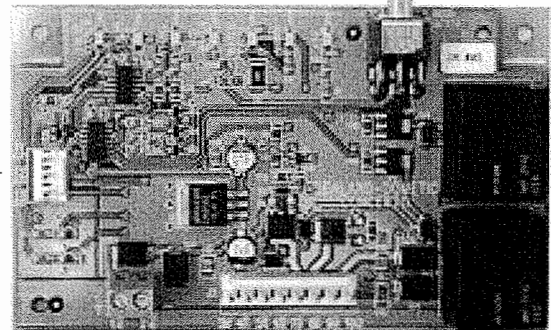

REMOTE FLUSH SWITCH (3400 series)

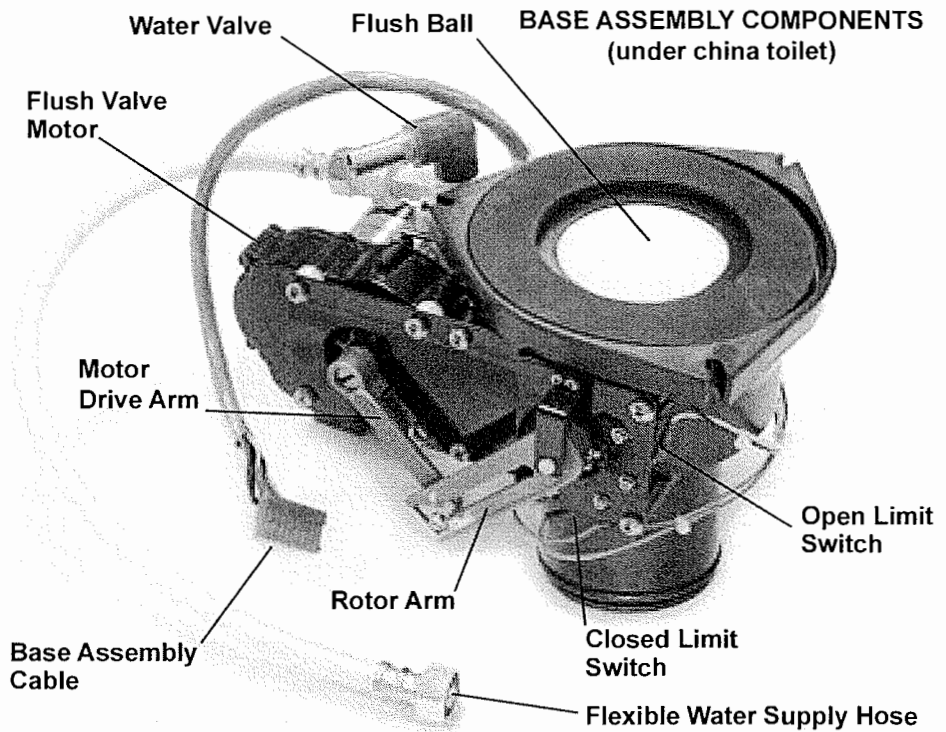
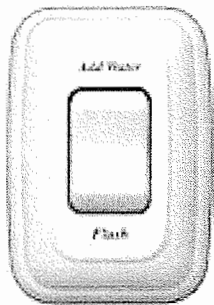

TOILET SYSTEM ELECTRICAL SPECIFICATIONS

12VDC

Maximum standby current (amps):	.070
Maximum operating current (amps):	6.5
Flush motor locked rotor current (amps):	14.5
Maximum voltage	15
Minimum voltage:	10
Input power wire size	14 ga.
All other wires size:	18 ga.
Fuse size (amps)	8

TROUBLESHOOTING

A volt/ohmmeter (VOM) and the Toilet Wiring Diagram may be required for this section.

Caution: Portions of this section will require that power be applied to the toilet. Keep hands away from the flush ball, motor drive arm and rotor shaft to prevent personal injury during testing and troubleshooting.

The control module uses a microprocessor to provide all the automatic and timing functions. The module is under the access cover. The control module has input and output status lights that can be used in troubleshooting the toilet.

The program in the microprocessor monitors the input and output signals during a normal flush cycle. If the inputs or outputs do not follow the commands of the program, then the microprocessor may go into a "standby" mode and flash an "error code." The microprocessor is reset by placing the Mode switch in the SERVICE position temporarily, then returning the switch to the NORMAL position.

A safety circuit in the control module monitors flush ball operation. If foreign objects or low voltage prevent the flush ball from closing, this circuit prevents personal injury or damage to the flush valve motor. If this condition occurs, reset the control module by placing the Mode switch into the SERVICE position temporarily, then returning it to the NORMAL position.

Status Light	Color	Function
1 Valve Closed	Green	Flush valve Closed Limit Switch engaged.
2 Valve Open	Green	Flush valve Open Limit Switch engaged.
3 Flush	Green	Flush handle or wall switch in "Flush" position.
4 Add Water	Green	Flush handle or wall switch in "Add Water" position.
5 Water Valve	Green	Electric water valve energized.
6 Status	Green	Status/error codes
7 +5V	Green	Input power

ERROR CODES

Status Light	No. of Flashes	Pause	Condition
6	1	.5 sec.	Mode Switch in SERVICE position
6	1	2 sec.	VALVE OPEN Limit Switch problem
6	2	2 sec.	VALVE CLOSED Limit Switch problem

CONTROL MODULE STATUS LIGHTS

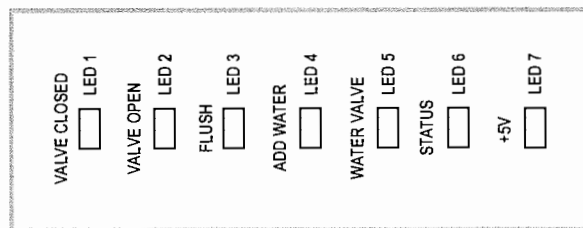



TROUBLESHOOTING (cont'd)

ERROR CODE CORRECTIVE PROCEDURES

<i>Condition</i>	<i>Corrective Action</i>
Mode Switch in SERVICE position.	Return Mode Switch to NORMAL position.
Valve Open Limit Switch problem.	With the flush valve fully open, check the "VALVE OPEN" status light. If the light is off , then the Valve Open Limit Switch is out of alignment or defective, or related wiring is defective.
Valve Closed Limit Switch problem.	With flush valve in the fully closed position check the "VALVE CLOSED" status light. If the light is off , then the Valve Closed Limit Switch is out of alignment or defective, or related wiring is defective.

TOILET OPERATION

SYMPTOM 1. Toilet will not flush and water will not enter toilet bowl.

<i>Condition</i>	<i>Corrective Action</i>
+5V status light is off :	 <ul style="list-style-type: none">• Check toilet fuse or circuit breaker at DC distribution panel.• Check for loose or defective wiring between control module and DC distribution panel.• Check for reverse polarity of input power to control module.• If all of above check OK, replace control module.
+5V status light is on :	 <ul style="list-style-type: none">• Input power must be 10 volts or higher.• Check control module for error codes.• Put Mode Switch in SERVICE position. If flush valve opens, go to next step. If the flush valve does not open, go to Symptom 2.• Put the Mode Switch in NORMAL position and push handle or switch to "Flush" while observing "FLUSH" status light. The "FLUSH" status light must come on when the switch is pushed and go off when the switch is released. If the "FLUSH" status light did not follow commands of switch, then flush switch or related wiring is defective.

SYMPTOM 2. Flush valve will not open when the Mode Switch is in the SERVICE position or when the flush handle or switch is pushed to "Flush" while in the NORMAL position.

<i>Procedure</i>	<i>Corrective Action</i>
Check the voltage output to the flush valve motor at pins 9 and 10 on the control module as follows:	 <ul style="list-style-type: none">• Pull the control module out as far as the control cables will allow.• Disconnect either the purple or yellow wire from the Open Limit Switch.• With DC voltmeter test leads across pins 9 and 10, flip the Mode Switch between the NORMAL and SERVICE positions. If voltage is present for about two seconds in the SERVICE position, the flush valve motor or related wiring is defective. If voltage is not present, replace the control module.

TROUBLESHOOTING (cont'd)

SYMPTOM 3. Flush valve will not close.

Condition/Procedure

Mode Switch is in SERVICE position:

Foreign object prevents the flush valve from closing and the safety circuit locked flush valve in open position:

Check the voltage output to the flush valve motor at pins 9 and 10 on the control module as follows:



Corrective Action

- Return switch to the "Normal" position.
- Reset the control circuit by putting the Mode Switch in the SERVICE position temporarily, then returning to the NORMAL position. If the flush valve **did not** close, go to next step.
- Pull the control module out as far as the control cables will allow.
- Disconnect either the orange or green wire from the Closed Limit Switch.
- With DC voltmeter test leads across pins 9 and 10, flip the Mode Switch between the SERVICE and NORMAL positions. If voltage is present for about two seconds in the NORMAL position, the flush valve motor or related wiring is defective.
- If voltage is not present, replace the control module.

SYMPTOM 4. Water will not enter toilet bowl during a flush and when the flush handle is raised or the flush switch is pushed to "Add Water".

Procedure

Check the "WATER VALVE" status light while pushing the "Flush" switch on the control panel:



Corrective Action

- If the "WATER VALVE" status light comes on, the water valve filter screen may be plugged with debris, or the water valve or its related wiring is defective.
- If the "WATER VALVE" status light remains off, replace the control module.
- If voltage is not present, replace the control module.

SYMPTOM 5. Flush valve will not open when Mode Switch is in the "Service" position but opens during a normal flush cycle.



Corrective Action

- Replace control module.

TROUBLESHOOTING (cont'd)

SYMPTOM 6. Water will not stay in bowl.

Condition/Procedure

Put Mode Switch in "Service" position:

Worn or damaged flush valve ball and seal:

Corrective Action

- Clean underside of flush valve ball seal of dirt and debris.
- Remove toilet from floor and remove base assembly from toilet and replace flush valve ball and seals.

SYMPTOM 7. Water will not shut off and overflows the toilet.

Procedure

Check the "WATER VALVE" status light:



Corrective Action

- If the light is **on** when **not** flushing the toilet or adding water, replace the control module. If the light responds correctly, go to next step.
- Dirt or debris lodged in the water valve seal. Remove the toilet from the floor, disassemble and clean water valve.
- Replace water valve.

SYMPTOM 8. Water is leaking from under the toilet.

Procedure

Remove the toilet from the floor and inspect the following with both water and electrical power applied:
(Place a container under the base assembly to catch any water during the inspection procedure.)



- Water hoses and fittings, water valve assembly
- China toilet bowl
- Upper base seal
- Flush valve ball rotor shaft shaft
- Base assembly

WIRING DIAGRAMS

3300 SERIES (with flush handle)

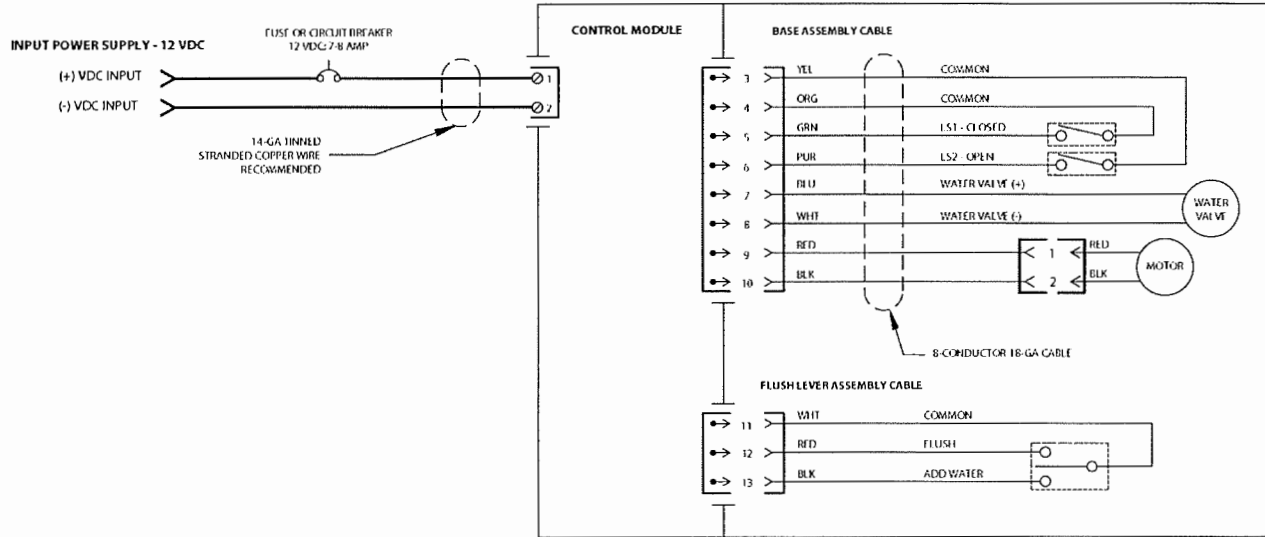

NOTES:
HEAVY LINES REPRESENT 14 GA. STRANDED COPPER WIRE.
ALL OTHER WIRE CAN BE 18 GA. STRANDED COPPER WIRE.

3400 SERIES (with remote flush switch)

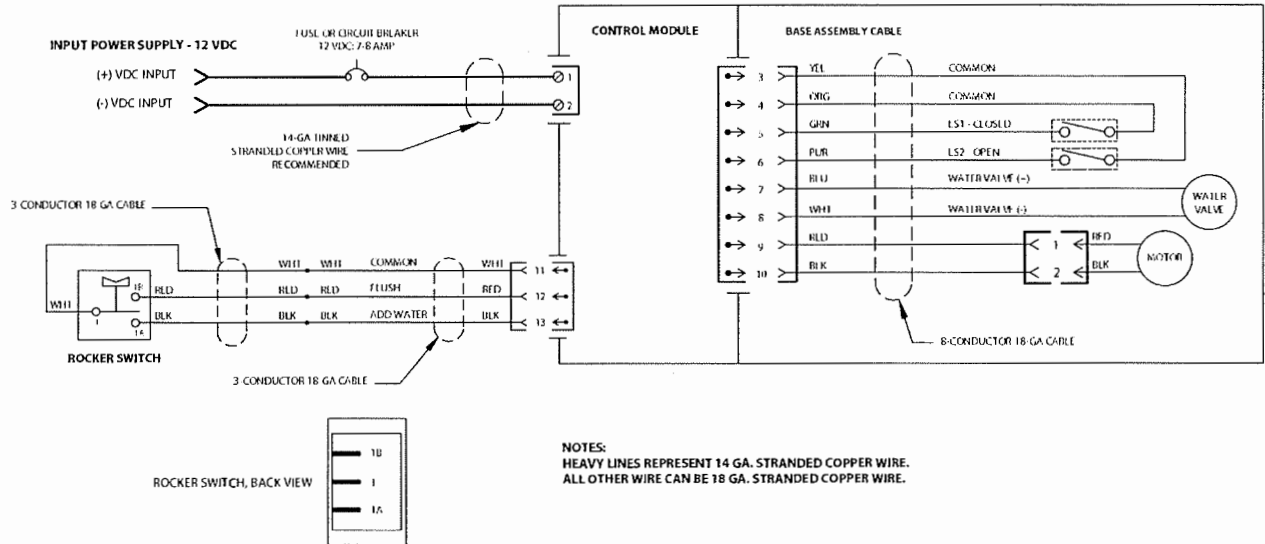

NOTES:
HEAVY LINES REPRESENT 14 GA. STRANDED COPPER WIRE.
ALL OTHER WIRE CAN BE 18 GA. STRANDED COPPER WIRE.

CUSTOMER SERVICE

There is a strong, worldwide network to assist in servicing and maintaining your sanitation system. For the Authorized Service Center near you, please call from 8:00 a.m. to 5:00 p.m. (ET) Monday through Friday. You may also write us at Dometic Corp., P.O. Box 38, Big Prairie Ohio 44611.

Telephone: 1 800-321-9886 U.S.A. and Canada
330-496-3211 International

You may also contact or have your local dealer contact the Parts Distributor nearest you for quick response to your replacement parts needs. They carry a complete inventory for the SeaLand product line.

Fax: 330-496-3097 U.S.A. and Canada
330-496-3220 International

U.S.A. MASTER SANITATION DISTRIBUTORS

U.S.A. - North Central (IL, IN, KY, MI, OH)

Midwest Marine Supply
24300 Jefferson Ave.
St. Clair Shores, MI 48080
Tel: 586-778-8950
800-860-1540
Fax: 586-778-6108
E-mail: midwestmarine@yahoo.com

U.S.A. - Northeast (CT, DE, DC, MA, MD, ME, NH, NJ, NY, PA, RI, VA, VT, WV)

Northeast Marine Sanitation
69 Florida Street
Farmingdale, NY 11735
Tel: 631-752-7606
800-352-4323
Fax: 631-752-7615
888-283-7606
E-mail: northeast@northeast sanitation.com

U.S.A. - Northwest (AK, ID, MT, OR, WA, WY)

Marine Sanitation, Inc.
1900 N. Northlake Way, Suite 121
Seattle, WA 98103
Tel: 206-633-1110
800-624-9111
Fax: 206-633-0317
E-mail: marinesan@mindspring.com

U.S.A. - South Central (AR, KS, LA, MO, MS, NM, OK, TX)

AER Supply
P.O. Box 349
2301 Nasa Road #1
Seabrook, TX 77586
Tel: 281-474-3276
800-767-7606
Fax: 281-474-2714
E-mail: sales@aersupply.com

U.S.A. - Southeast (AL, FL, GA, NC, PR, SC, TN, VI)

Environmental Marine
111 S.W. 23rd Street, Suite A
Fort Lauderdale, FL 33315
Tel: 954-522-2626
800-522-2656
Fax: 954-522-5152
E-mail: info@environmentalmarine.com

U.S.A. - Southwest (AZ, CO, NV, UT, CA-south)

Ardemco Marine Specialties
778 West 17th Street
Costa Mesa, CA 92627
Tel: 949-722-7672
800-253-0115
Fax: 949-642-9582
E-mail: info@ardemco.com

U.S.A. - Upper Midwest (IA, MN, NE, ND, SD, WI)

PowerHouse Marine
518 Logan
La Crosse, WI 54603
Tel: 608-784-9580
888-752-4539
Fax: 608-784-8422
E-mail: dave@powerhousemarine.com

U.S.A. - Northern California

Fox Marine
2250 Zanker Road, Unit D
San Jose, CA 95131
Tel: 408-451-9055
800-826-2873
E-mail: foxmarco@pacbell.net

CANADA MASTER SANITATION DISTRIBUTORS

Canada - East

Eastern Marine Systems, Inc.
12-A Leslie Street
Toronto, Ontario M4M 3H7
Tel: 416-465-1668
888-764-1111
Fax: 416-465-2098
E-mail: info@eastmar.com

Canada - West

Western Marine Company
1494 Powell Street
Vancouver, BC V5L 5B5
Tel: 604-253-7721
800-663-0600
Fax: 604-253-2656
800-663-6790
E-mail: sales@westernmarine.com

INTERNATIONAL SEALAND SANITATION SYSTEM DISTRIBUTORS

Call 1-800-321-9886, email us at sealand@dometicsusa.com, or visit www.dometicsusa.com for the distributor nearest you.

MANUFACTURER'S THREE-YEAR AND TEN-YEAR LIMITED WARRANTIES

Dometic Corporation warrants, to the original purchaser only, that this Concerto® gravity discharge toilet, if used for personal, family or household-like purposes, is free from defects in material and workmanship for a period of three (3) years from the date of purchase.

Dometic also warrants, to the original purchaser only, that the vitreous china toilet bowl will not discolor, stain, scratch or craze for a period of ten (10) years if used for personal, family or household-like purposes, and is regularly cleaned as described in the product's owner's manual.

If this Dometic product is placed in commercial or business use, it will be warranted, to the original purchaser only, to be free of defects in material and workmanship for a period of ninety (90) days from the date of purchase.

Dometic reserves the right to replace or repair any part of this product that proves, upon inspection by Dometic, to be defective in material or workmanship. All labor and transportation costs or charges incidental to warranty service are to be borne by the purchaser-user.

EXCLUSIONS

IN NO EVENT SHALL **DOMETIC** BE LIABLE FOR INCIDENTAL OR CONSEQUENTIAL DAMAGES, FOR DAMAGES RESULTING FROM IMPROPER INSTALLATION, OR FOR DAMAGES CAUSED BY NEGLIGENCE, ABUSE, ALTERATION, OR USE OF UNAUTHORIZED COMPONENTS. THIS INCLUDES FAILURES WHICH MAY RESULT FROM NOT FOLLOWING THE WINTERIZATION OR CLEANING PROCEDURES AS DESCRIBED IN THIS MANUAL. ALL IMPLIED WARRANTIES, INCLUDING ANY IMPLIED WARRANTY OF MERCHANTABILITY OR FITNESS FOR ANY PARTICULAR PURPOSE, ARE LIMITED TO A PERIOD OF ONE (1) YEAR FROM DATE OF PURCHASE.

IMPLIED WARRANTIES

No person is authorized to change, add to, or create any warranty or obligation other than that set forth herein.

Implied warranties, including those of merchantability and fitness for a particular purpose, are limited to one (1) year from the date of purchase for products used for personal, family or household-like purposes, and ninety (90) days from the date of purchase for products placed in commercial or business use.

OTHER RIGHTS

Some states do not allow limitations on the duration of an implied warranty, and some states do not allow exclusions or limitations regarding incidental or consequential damages; so, the above limitations may not apply to you. This warranty gives you specific legal rights, and you may have other rights which vary from state to state.

To obtain warranty service, first contact your local dealer from whom you purchased this product.



Dometic Corporation • Sanitation Systems

13128 State Rt 226, PO Box 38

Big Prairie, OH 44611

SeaLand Product Customer Service: 1-800-321-9886

(8:00 a.m. - 5:00 p.m. ET)

® Registered; ™ Trademark of Dometic Corporation
® Bar Keepers Friend is a registered trademark of SerVaas Laboratories.
© Dometic Corporation