

Electronic Brake Control For 2, 4, and 6 brake applications

READ THIS FIRST:

Read and follow all instructions carefully before installing or operating the Brake Control. Keep these instructions with the Brake Control for future reference.

Components of the Brake Control

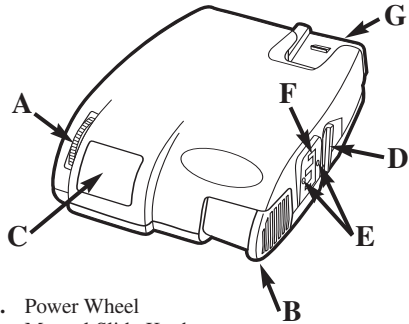

- A. Power Wheel
- B. Manual Slide Knob
- C. Two Digit Power Display
- D. Sensor Positioning Arm
- E. Bracket Mounting Holes
- F. Dash Mounting Clip Attachment Locations
- G. Connector (For Wiring Harness)

Important Facts to Remember

1. Do not mount or activate RF generating items (cell phones, two way radios) near the Brake Control (less than 12").
2. **CAUTION**
Reversing the connection to a breakaway battery on the trailer will destroy the Brake Control.
3. **CAUTION**
Disconnect trailer plug from the tow vehicle prior to testing a breakaway switch or you may destroy the Brake Control.
4. **WARNING**
The sensor adjustment is CRITICAL. The sensor adjustment determines whether automatic braking response is delayed or aggressive.
5. This Brake Control is activated by inertia. It senses deceleration and generates an output that reflects the inertia sensed. In a stationary state, the Brake Control will not apply the trailer brakes unless the Manual Slide Knob is actuated.

6. **WARNING**

The Gross Combined Weight Rating (GCWR) must never exceed the vehicle manufacturers recommendation.

7. This Brake Control is specifically designed for use with electric trailer brakes.
8. For Technical Assistance and Warranty Information call: 1-888-785-5832 or www.tekonsha.com

Installation Guide

WARNING

The Brake Control must be mounted from horizontal to 70 degrees nose up (see below.) Failure to install Brake Control within these constraints may cause your control to become inoperable.

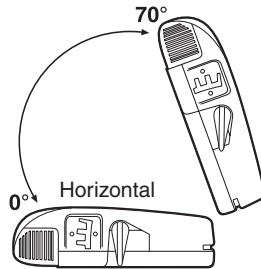

NOTE:

1. Front of Brake Control must be horizontal, *see below.*
2. The Brake Control must be parallel to direction of travel (A), *see below.*

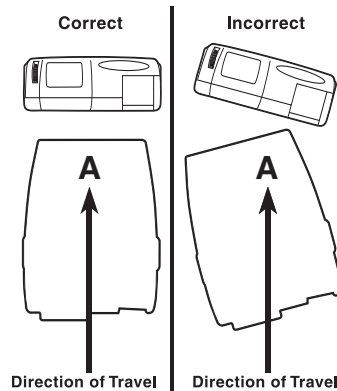

Wiring Brake Control

Your Brake Control has a unique connector located at the back of the control. This connector allows you two options to wire your Brake Control.

Option 1:

Use Pigtail Wiring Harness included. This harness can be installed by following the Generic Wiring Instructions.

Option 2:

Use a vehicle specific wiring harness. If your vehicle came with a factory tow package that included a 7-way connector, you may be able to purchase an OEM wiring harness with the Brake Control connector on one end and your specific vehicle's connector on the other. See Generic Wiring Instructions, for location of your vehicle's connector.

Traditional Bracket Mount

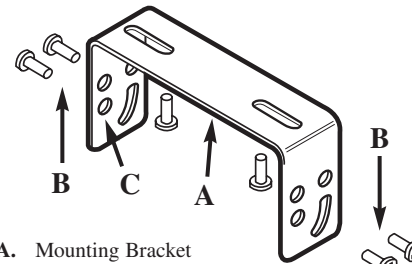

- A. Mounting Bracket
- B. #6 x 3/8" Screws
- C. Brake Control Mounting Holes

1. **CAUTION**

Drilling or use of longer screws may damage the unit or your vehicle.

2. Securely mount bracket to a solid surface.
3. Insert supplied #6 x 3/8" screws on each side into the mounting holes.
4. Adjust Brake Control to desired position and tighten screws until snug, obtaining the proper mounting angle (see Installation Guide).

Dash Mounting Clip

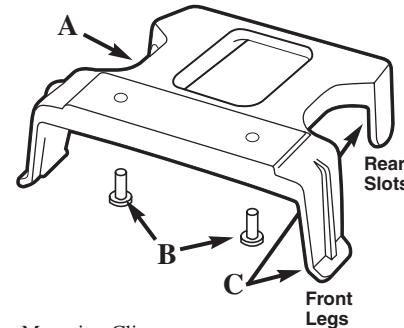

- A. Mounting Clip
- B. #6 x 3/8" Screws
- C. Brake Control Attachment Locations

1. **CAUTION**

Drilling or use of longer screws may damage your vehicle.

2. Securely mount dash clip to a solid surface.

Attaching Brake Control To Dash Mounting Clip

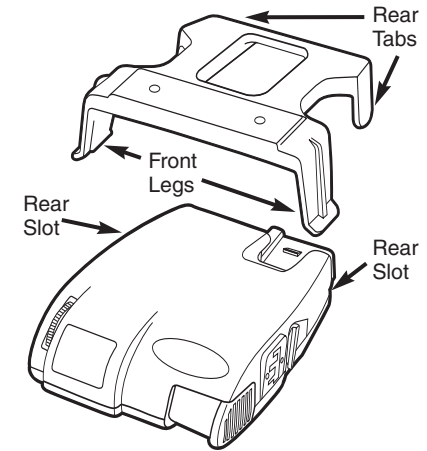

WARNING

Failure to properly secure the Brake Control into the dash mounting clip may result in loss of or improper operation of the Brake Control.

1. After securely mounting the dash clip to a solid surface the Brake Control can be attached.
2. Connect wiring harness connector to the Brake Control.
3. Slide the Brake Control into the dash clip so that the rear slots in the Brake Control engage with the rear tabs of the clip.
4. Spread apart the front legs of the dash clip and raise the front of the Brake Control to engage with the clip.
5. **WARNING**
The dash clip allows for three mounting adjustments on each side of the control. The Brake Control must be mounted correctly. Final mounting position should be in the same adjustment slot on each side of the control (see figure 1).
6. Adjust Brake Control to desired position obtaining the proper mounting angle (see Installation Guide).

Brake Control Attachment to Dash Mounting Clip (Figure 1)

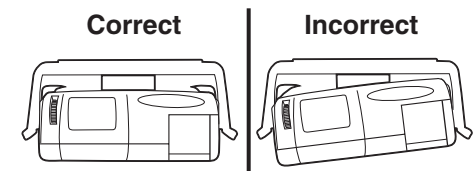

2 Digit Power Display Legend

- Trailer connected.



- Without trailer connected.

(Blank Display)

- Manual Slide Knob or tow vehicle brakes applied and trailer connected, 5.4 denotes a hypothetical power output. This is an indication of voltage output to electric brakes.



- Manual Slide Knob applied without trailer connected.



- Trailer disconnection. Flashes n.c for 15 seconds.



NOTE:

Display shows tenths of a volt up to 9.9. After 9.9 the display shows whole digits only.

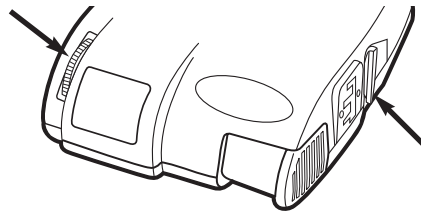

Setting the Sensor Positioning Arm and Power Wheel

NOTE:

1. ⚠️ WARNING

This Brake Control is activated by inertia and requires the sensor to be set properly, or the braking response will be too harsh or ineffective.

- When the Brake Control sensor is properly set there will be very little current flowing through the brake magnets in a static state with the foot pedal depressed. The brake magnets will hum when there is current flowing through them. Anytime brake output power is displayed there is current flowing through the brake magnets.

Once the Brake Control has been installed, it is necessary to set the sensor and the power needed to stop the trailer during a braking event.

- Connect trailer to the tow vehicle and park on a level surface.
- For best results, rotate the Power Wheel toward the front of the vehicle, to full power.
- With the vehicle stopped, completely rotate the Sensor Positioning Arm toward the rear of the vehicle. Apply the brakes and slowly rotate the Sensor Positioning Arm toward the front of the vehicle to where the display shows between 0.1 to 0.9 (Note: this is the Minimum Aggressive Setting).
- With the vehicle still stopped, locate the Manual Slide Knob and Power Wheel on the control. While applying the Manual Slide Knob rotate the Power Wheel until display reads between 4.0 to 5.0.

NOTE:

- Always warm the trailer's brakes before fine tuning the power. Warm trailer brakes tend to be more responsive than cold brakes. To warm trailer brakes, drive a short distance (1/4 mile) at 45 MPH with manual lever engaged enough to cause trailer braking at a low level.
- ⚠️ WARNING**
The power should never be set high enough to cause trailer brakes to lock up. Skidding trailer wheels can cause loss of directional stability of trailer and tow vehicle.
- Not all trailer brakes will lock up due to various conditions. However, inability to lock up the brakes generally indicates the need for an inspection to determine the cause.
- The power may need to be adjusted for different load weights and road conditions.
- When the power is set correctly you should feel unified braking between the trailer and tow vehicle.

Fine Tuning the Power

Once the Brake Control sensor and power have been given an initial setting it is necessary to fine tune the power setting for the power needed to stop the trailer during a braking event.

- Drive tow vehicle and trailer on a dry level paved surface at 25 mph and fully apply Manual Slide Knob.

If trailer brakes lock up:

Turn power down using Power Wheel.

If braking was not sufficient:

Turn power up using Power Wheel.

- Repeat Step (1) until power has been set to a point just below wheel lock up or at a sufficient force as to achieve maximum braking power.

Fine Tuning the Sensor



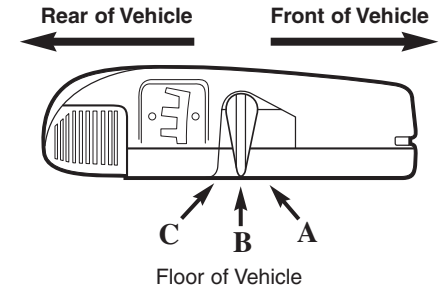

Now that the power has been set, it is time to fine tune the sensor setting for the majority of the stopping that you will be doing.

- Drive tow vehicle and trailer on a dry level paved surface and make several slow (25 MPH) stops as if coming up to a stop sign and take notice of how the trailer brakes respond.
- Trailer Tending to Push Tow Vehicle**
 - You have a Delayed Setting:
To correct this condition - apply the brakes with the vehicle stopped and take note of the power display reading. Using the Sensor Positioning Arm, increase the display, about 0.5 at a time, by rotating the Sensor Positioning Arm toward the rear of the vehicle. Repeat steps #1 and #2 until desired trailer braking is achieved.
- Brakes Grab Too Much**
 - You have an Aggressive Setting:
To correct this condition - apply the brakes with the vehicle stopped and take note of the power display reading. Using the Sensor Positioning Arm, decrease the display, about 0.5 at a time, by rotating the Sensor Positioning Arm toward the front of the vehicle. Repeat step #1 and #3 until desired trailer braking is achieved.



- A. Delayed
- B. Normal
- C. Aggressive

Troubleshooting Chart

Display	Situation	Probable Cause
	Flashes for 15 seconds	Trailer connector is disconnected or corroded. After 15 seconds display switches to a blank display.
		Manual Slide Knob applied without trailer connected or applying the Manual Slide Knob after the display has flashed n.c. for 15 seconds.
		When stopping indicates the power knob is set all the way to the minimum setting.
		Short circuit detected on brake output with manual applied and maximum power setting.

Appendix A: Trailer Brake Adjustment**

Brakes should be adjusted after the first 200 miles of operation when the brake shoes and drums have "seated" and at 3000 mile intervals, or as use and performance requires. The brakes should be adjusted in the following manner:

1. Jack up trailer and secure on adequate capacity jack stands. Follow trailer manufacturers recommendations for lifting and supporting the unit. Check that the wheel and drum rotate freely.
2. Remove the adjusting hole cover from the adjusting slot on the bottom of the brake backing plate.
3. With a screwdriver or standard adjusting tool, rotate the starwheel of the adjuster assembly to expand the brake shoes. Adjust the brake shoes out until the pressure of the linings against the drum makes the wheel very difficult to turn.

Note: With drop spindle axles, a modified adjusting tool with about an 80 degree angle should be used.

4. Then rotate the starwheel in the opposite direction until the wheel turns freely with a slight lining drag.
5. Replace the adjusting hole cover and lower the wheel to the ground.
6. Repeat the above procedure on all brakes.

⚠️ WARNING

Never crawl under your trailer unless it is resting on properly placed jack stands.

Follow the trailer manufacturers recommendations for lifting and supporting the unit. Do not lift or place supports on any part of the suspension system.

**Note: Trailer Brake Adjustment procedures courtesy Dexter Axle.

Commande de frein électronique Pour applications de 2, 4 et 6 freins

LISEZ CECI EN PREMIER:

Il importe de lire ou de suivre attentivement toutes les consignes avant de poser ou d'utiliser la commande de frein. Ces consignes doivent être conservées avec la commande de frein pour consultation future.

Composants de la commande de frein

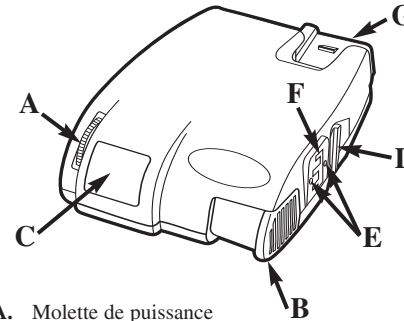

- A. Molette de puissance
- B. Bouton de frein manuel
- C. Affichage de puissance à deux chiffres
- D. Bras de positionnement du capteur
- E. Trous de montage du support
- F. Emplacements des attaches de montage sur tableau de bord
- G. Connecteur (pour faisceau de fils)

Faits importants à garder en mémoire

1. Ne pas monter ni actionner des appareils produisant des ondes RF (téléphones cellulaires, radios bidirectionnelles) à proximité (moins de 12 po/30 cm) de la commande de frein.
2. ⚠️ **ATTENTION**
L'inversion de la connexion à une batterie de dérive sur la remorque détruira la commande de frein.
3. ⚠️ **ATTENTION**
Débrancher la fiche de remorque du véhicule de remorquage avant de faire l'essai d'un interrupteur de dérive, sinon il existe un risque de détruire la commande de frein.
4. ⚠️ **AVERTISSEMENT**
Le réglage du capteur est CRITIQUE. C'est lui qui détermine si la réponse automatique des freins sera différée ou agressive.
5. Cette commande de frein est activée par inertie. Elle perçoit la décélération et génère une sortie qui reflète l'inertie captée. Dans un état stationnaire, la commande de frein n'appliquera pas les freins de remorque sauf si le bouton de frein manuel est utilisé.

6. ⚠️ **AVERTISSEMENT**

Le poids technique maximal combiné (Gross Combined Weight Rating – GCWR) ne doit jamais dépasser les recommandations du fabricant du véhicule.

7. Cette commande de frein est spécifiquement conçue pour être utilisée avec des freins de remorque électriques.
8. Pour de l'assistance technique ou des informations concernant la garantie, prière d'appeler le 1-888-785-5832 ou www.tekonsha.com.

Guide d'installation

⚠️ **AVERTISSEMENT**

La commande de frein doit être montée selon un angle de 0 à 70 degrés, nez vers le haut (voir ci-dessous). Le fonctionnement de la commande de frein pourrait être entravé si celle-ci n'est pas montée en respectant ces contraintes.

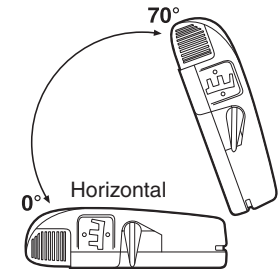

REMARQUE:

1. Le devant de la commande de frein doit être horizontal, voir ci-dessous.
2. La commande de frein doit être parallèle au sens de marche (A), voir ci-dessous.

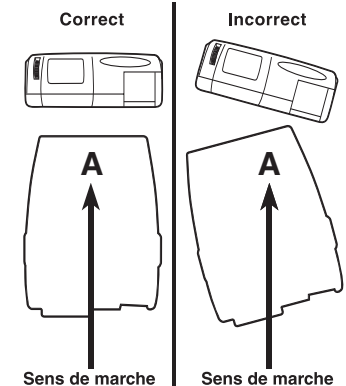

Branchement de la commande de frein

Votre commande de frein est dotée d'un unique connecteur situé à l'arrière. Ce connecteur vous propose deux options pour brancher votre commande de frein.