

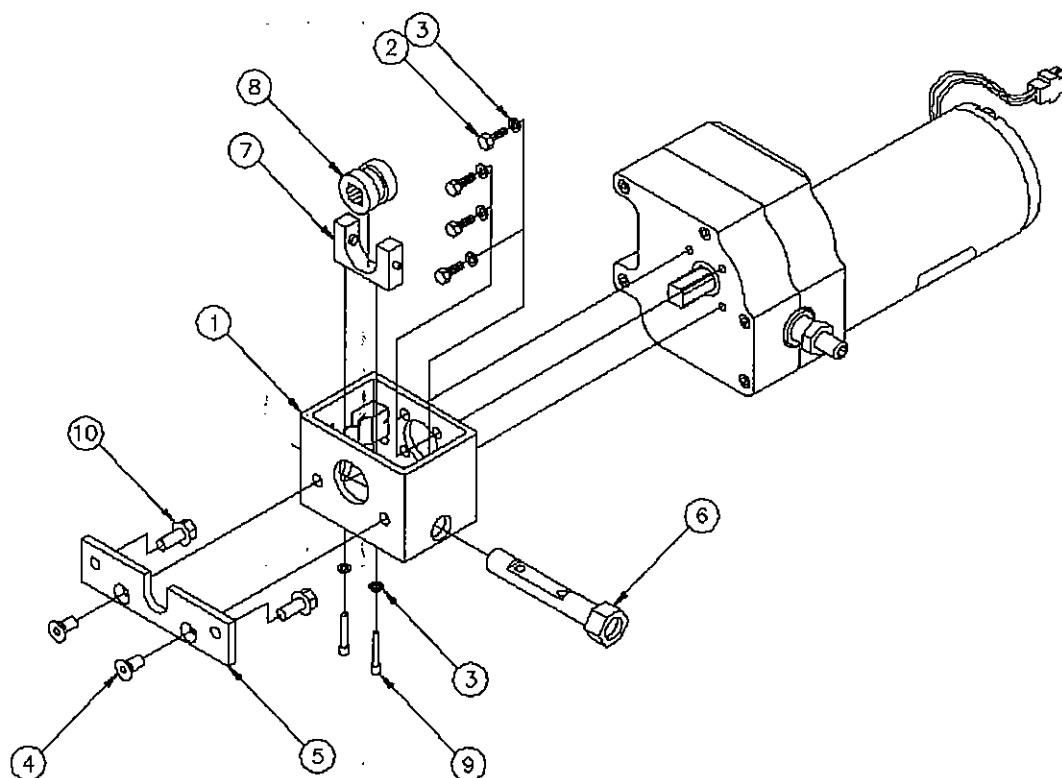

1217 E. 7<sup>th</sup> Street  
 Mishawaka, IN 46544  
 Phone: 1-800-334-4712  
 1-888-339-2539  
 Fax: 574-256-6743

# T.I.P. Troubleshooting Information on Power Gear

## SERVICE KIT CHANGING 4-BOLT OVER-RIDE TO QUICK DISCONNECT



### SERVICE KIT CONTENTS: P/N 800066

P/N	DESCRIPTION	QTY	BALLOON #
DN14368	HOUSING ADJUSTER ASSY	1	1
DN12403	SCREW HHC 1/4-20 X 3/4	4	2
VF10300	LOCKWASHER 1/4" SPLIT	6	3
DN13769	SCREW FHC 5/16-18 X 5/8	2	4
DN13736	DISENGAGEMENT BOX MTG PLATE	1	5
DN13596	MOTOR DISENGAGEM'T SHAFT ASS'Y	1	6
DN13591	MOTOR ENGAGEMENT YOKE ASS'Y	1	7
DN13597	1" MOTOR DISENGAGEMENT COLLAR	1	8
DN13816	SCREW SHC 1/4-28 X 1	2	9
150-1468	FLANGE BOLT 5/16-18 X 3/4	2	10

### TOOLS NEEDED:

- 1/2" Wrench
- 7/16" Wrench
- 3/16" Hex Key (ALLEN TYPE)
- Loc-tite
- 15/16" Wrench

TIP Sheet #166  
 82-S0342-T  
 07-02  
 1 of 2

**TO REMOVE OLD DISENGAGEMENT BOX:**

1. Locate and remove access panel to slide-out mechanism.
2. Disconnect slide-out motor electrical connection.
3. Using a ½" wrench, loosen the (4) 5/16-18 x ¾ hex head cap screws on the drive shaft coupler inside the disengagement box.
4. Using a ½" wrench, remove the (2) 5/16-18 x ¾ flange bolts, same as Item #10 on diagram, and now the motor is free to be moved to a better workspace.
5. At this point, the coupler is free to be removed and may be discarded.
6. Using a 3/16" hex key, remove the (2) 5/16-18 x 5/8 flat head cap screws, same as Item #4, to remove the disengagement box mounting plate, and these parts may be discarded. *Note: These screws may be difficult to remove because Loc-tite may have been used when assembled at the factory.*
7. Using a 7/16" wrench, remove the (4) ¼-20 x ¾ hex head cap screws with lockwashers, same as Items #2 and #3, that mount the disengagement box to the motor gearbox, and these parts may be discarded.
8. At this point, only the motor with the gearbox, as shown on the right side of the diagram, is the only part needed for the re-assembly.

**TO REASSEMBLE MOTOR WITH QUICK DISCONNECT ASSEMBLY:**

1. Mount the housing adjuster assembly (Item #1) to the motor gearbox using a 7/16" wrench, (4) ¼-20 x ¾ hex head cap screws (Item #2), and (4) ¼" split lockwashers (Item #3). *Note: The diagram shows the proper orientation of the housing adjuster assembly to the motor and gearbox.*
2. Mount the disengagement box mounting plate (Item #5) to the housing adjuster assembly (Item #1) using a 3/16" hex key and the (2) 5/16-18 x 5/8 flat head cap screws (Item #4). *Note: Applying Loc-tite to the threads of the screws will assure that they will not back out due to vibrations.*
3. Next, insert the motor disengagement shaft assembly (Item #6) into the housing adjuster assembly (Item #1) as shown in the diagram. *Note: It is possible, but not recommended, to assemble backwards.*
4. Insert 1" motor disengagement collar (Item #8) into the Motor engagement yoke assembly (Item #7).
5. Insert the collar and yoke assembly into the housing adjuster assembly (Item #1) as shown in the diagram.
6. Using a 3/16" hex key, the (2) ¼-28 x 1 socket head cap screws (Item #9), and (2) ¼" split lockwashers (Item #3), attach the 1" motor disengagement collar (Item #8) and the motor engagement yoke assembly (Item #7) to the motor disengagement shaft assembly (Item #6).
7. At this point, the functioning can be checked before reinstalling the assembly by using a 15/16" wrench on the hex nut on the motor disengagement shaft assembly (Item #6). *Note: The functioning will not be that easy due to the force that is applied by the spring in the housing adjuster assembly to keep the collar engaged during travel and operation.*
8. Using a ½" wrench and the (2) 5/16-18 x ¾ flange bolts (Item #10), attach the new disengagement box and motor assembly to the slide-out mechanism.
9. Using a 15/16" wrench, turn the hex nut on the motor disengagement shaft assembly (Item #6) to reengage the gear driveshaft. *Note: The collar should slide right on if the motor has not been energized since being removed and the slide-out has not be moved in or out. If it does not line up correctly, the motor needs to be energized or the slide-out moved in or out until the driveshafts and the collar all match up.*
10. Reconnect slide-out motor electrical connection.
11. Replace the slide-out access panel.
12. Slide-out should now function normally.