

# 200 Amp Battery Disconnect

## The "Big Boy" of the Family

Intellitec's 200 Amp Battery Disconnect provides a simple, reliable, and cost effective means of remotely disconnecting the battery of larger vehicles. Rather than having to install long runs of heavy, unprotected battery cable to a large cumbersome switch, the Disconnect can be located near the battery, out of normal reach. It is connected to a low current switch conveniently located for the driver by a low current cable. The concern of long battery cables shorting to the chassis is all but gone.

The Battery Disconnect is designed incorporating Intellitec's patent No. 4,628,289, of a simple magnetic mechanism. It operates as a latching relay, drawing **NO** current to keep it closed or open. This latching feature allows the Disconnect to operate without discharging the battery.

To close the Disconnect, a positive voltage is applied to the unmarked terminal of the coil and the negative of the supply is connected to the "S" terminal, for a brief period. When the power is removed, the relay is latched in the "on" or closed position. Current can now flow through the large terminals.

Once closed, the Disconnect can safely carry up to 200 Amps of continuous DC current. Up to 1200 Amps can be drawn for periods of up to 30 seconds. To open the Disconnect, the power is momentarily applied to the coil in the reverse direction. When the power is removed, the Disconnect will be open.



131 Eisenhower Lane North  
Lombard, IL 60148  
630.268.0010 / 1.800.251.2408  
FAX 630.916.7890

[www.intellitec.com](http://www.intellitec.com)



The Disconnect is ignition protected, so it can safely be mounted in a convenient place near the battery. It can be mounted in any orientation.

It is immune to harsh shake and vibration found in the vehicle environment.

The Disconnect in a typical installation, is mounted near the vehicle battery to keep the length of the battery cables to a minimum. Keeping these wires short adds to the safety of the installation and helps minimize the cost. The wires to the Disconnect's coil are run to a remote switch, usually located at a convenient location near an entry door. Additional switches can be wired to allow operation of the Disconnect from multiple locations, such as the front and rear of a vehicle.

P/N 53-00507-000 Rev. B 040505

# 200 Amp Battery Disconnect

Intellitec's new **200 Amp Battery Disconnect** relay operates on the same principles as *Intellitec's* 100 Amp version that has been used by the industry for over ten years. These relays are covered by Patent No. 4,628,289. It is intended to be used in larger vehicles where the continuous current draw can be larger than 100 Amps. This relay can also handle heavy starter currents of large diesel engines.

## Specifications:

Part Number	00-00507-512	00-00507-524
Nominal Actuation Voltage	12 Volts	24 Volts
Actuation Current	5.6 Amps	2.8 Amps
Minimum Actuation Voltage	9 Volts	18 Volts
Maximum Continuous Carry Current		200 Amps
Maximum Short Term Carry Current (30 Seconds)		1200 Amps
Maximum Ambient Temperature		185 Degrees F.
Minimum Ambient Temperature		-40 Degrees F.
Contact Life at Full Load		Minimum of 10,000 Cycles
Maximum Actuation Time		0.2 Seconds

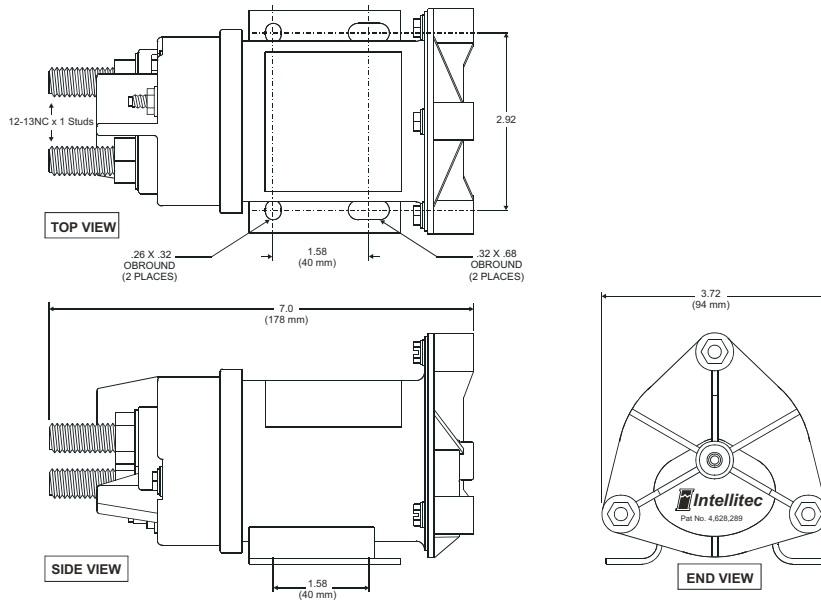

## Typical Wiring Diagram

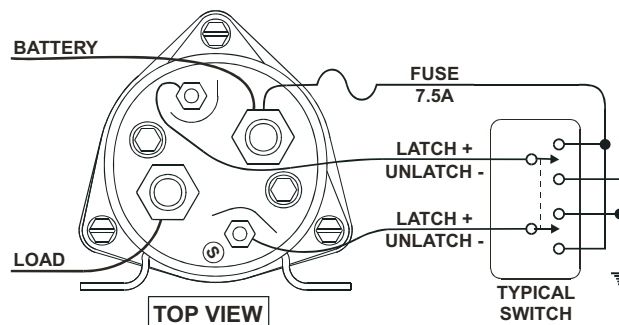

 **Intellitec**  
 131 Eisenhower Lane North  
 Lombard, IL 60148  
 630.268.0010 / 1.800.251.2408  
 FAX 630.916.7890

P/N 53-00507-000 Rev. B 040505