

BATTERY DISCONNECT

SERVICE MANUAL

Intellitec Battery Disconnect Panel, BD3, 01-00066-003



Warning: The Battery Disconnect system connects directly to the vehicle's positive battery terminal. Inadvertent shorts across the battery or to ground, may cause severe damage and injury. Use extreme caution when working with these wires. Always wear safety glasses when working with the battery connections.

Battery Disconnect provides a simple and safe means of remotely disconnecting batteries of an RV or boat. With a touch of a remote switch, the batteries will be completely disconnected, preventing unwanted drain when the RV / boat are put into storage.

The heart of the system is a unique latching relay developed specifically for this purpose. While this relay is capable of carrying heavy currents, it requires **NO** power to stay open or closed. It only draws power during activation. The relay is sealed against the environments and is designed to withstand the shock and vibration experienced in the most severe RV or boat applications.

BATTERY DISCONNECT

THE RELAY - How It Works

The Battery Disconnect Relay is a mechanically latching switch that operates by the momentary application of battery voltage to the coil terminals in one direction for latching (closed) or the other direction for unlatching (open).

To close the relay, +12 volts is applied to the "I" terminal and ground to the "S" terminal of the relay. When this is done, the plunger is pulled into the coil and the contacts are connected. While this happens, the rod magnet suspended above the plunger is attracted (opposite poles attract) to the top of the plunger by the magnetic field. See FIGURE 1

When the voltage is removed from the coil, the plunger gets pushed upward by the return spring, but cannot move because the rod magnet is in the way. See FIGURE 2

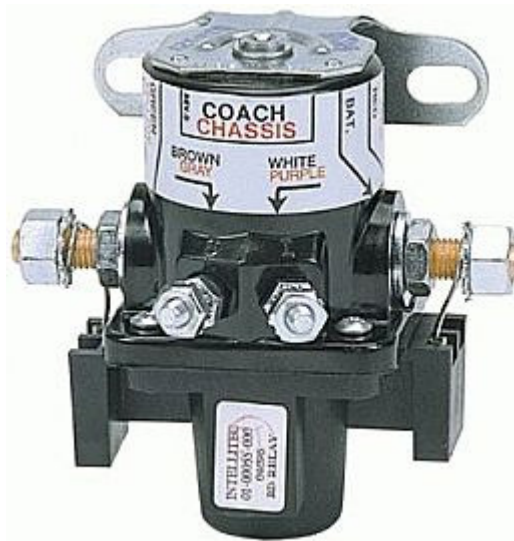

Intellitec Battery Disconnect Relay with No Fuses, 01-00055-002

<http://www.pdxrv.com/catalog/i1362.html>

BATTERY DISCONNECT

Relay Closing

Positive polarity applied to coil. Current flowing in coil. Plunger pulled in to coil. Rod magnet attracted to plunger by opposite polarity.

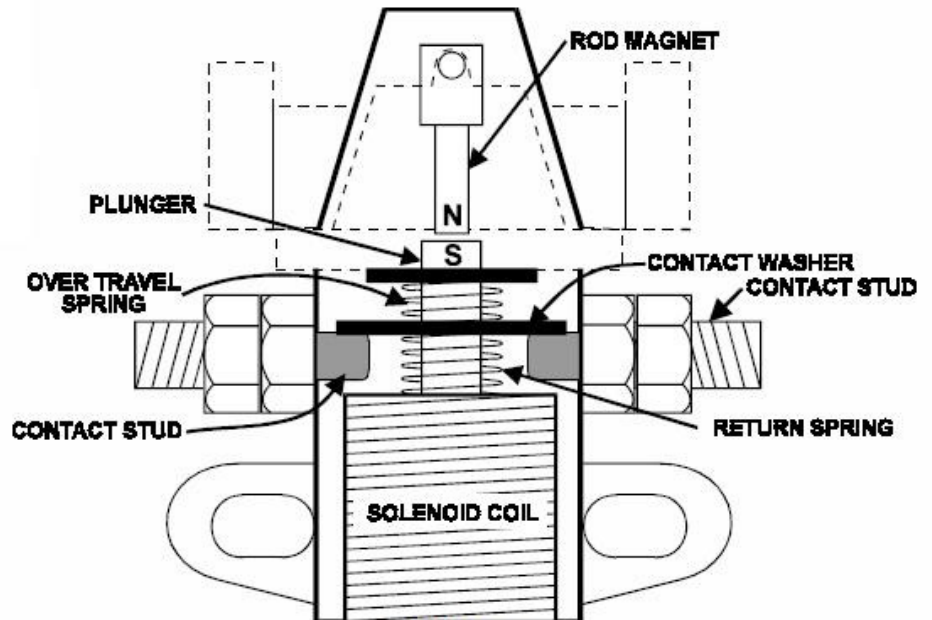

FIGURE 1

Relay Closed

Power removed from coil. Magnet blocks plunger from coming up, maintaining contact.

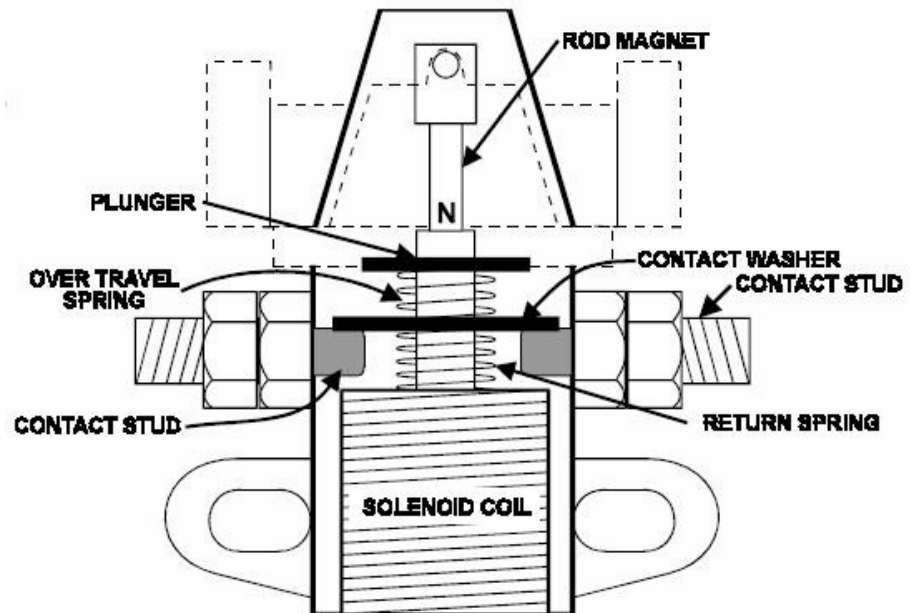
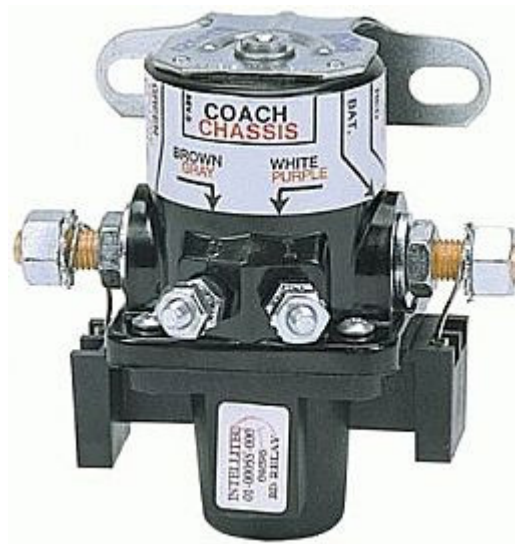

FIGURE 2

BATTERY DISCONNECT

To open the relay, +12 volts is applied to the “S” terminal and ground on the “I” terminal. When this is done, the plunger is again pulled into the coil. However, since the magnetic polarity of the coil is reversed, the rod magnet is repelled (like poles oppose), and swings out of the way. See FIGURE 3

When the voltage is removed from the coil, the plunger gets pushed upwards by the return spring, breaking the connection between the two large terminals. See FIGURE 4.



Intellitec Battery Disconnect Relay with Fuses, 01-0055-000

<http://www.pdxrv.com/catalog/i1361.html>

BATTERY DISCONNECT

Relay Opening

Negative polarity applied to coil. Current flowing in coil. Plunger pulled in. Rod magnet opposed by plunger same polarity magnetic field, swings out to side of housing.

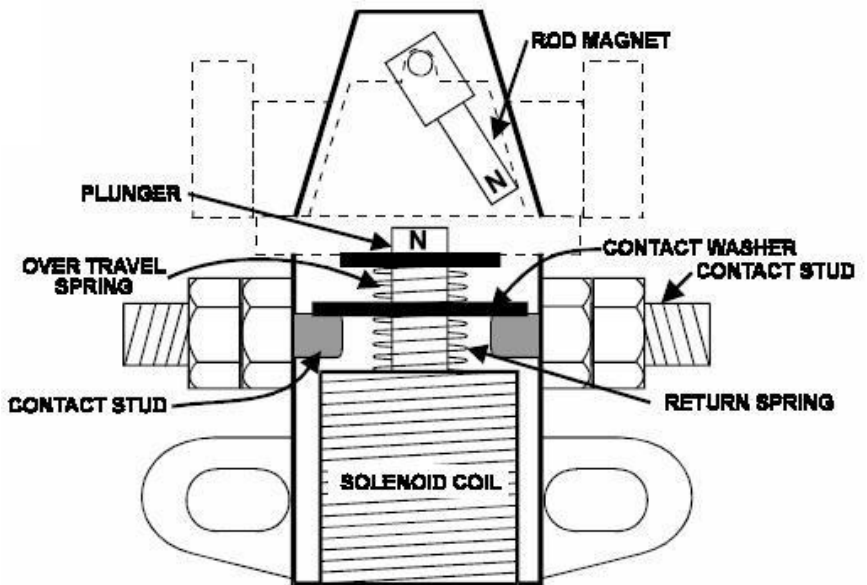

FIGURE 3

Relay Open

Power removed. No current flowing in coil. Plunger pushed up by return spring while magnet is off to the side. Contacts open. Magnet comes to rest at side of plunger.

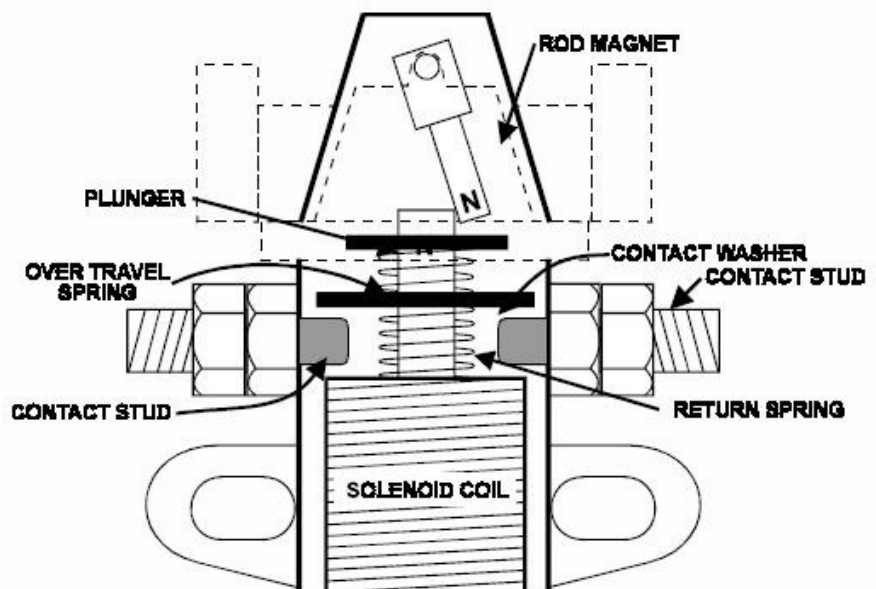

FIGURE 4

BATTERY DISCONNECT

THE SYSTEM

A typical motor home may use one or two relays to disconnect the batteries. These relays are usually independent and operate from a switch panel located inside the coach. A harness is used to connect from the panel to the relays. The Intellitec panels are offered in four models. They are:

BD0 - Single battery system, with a cable and monitor panel with an on/off indicator

BD0 (BLACK/SILVER) 01-00066-004 <http://www.pdxrv.com/catalog/i2755.html>

BD0 (BROWN/GOLD) 01-00066-000 <http://www.pdxrv.com/catalog/i1399.html>

BD1 - Single battery system, with a cable and monitor panel with an on/off indicator and digital voltmeter

BD1 (BLACK/SILVER) 01-00066-005 <http://www.pdxrv.com/catalog/i2757.html>

BD1 (BROWN/GOLD) 01-00066-001 <http://www.pdxrv.com/catalog/i1364.html>

BD2 - Dual battery system, with cable and monitor panel with two on/off indicators and ignition interlock relay.

BD2 (BLACK/SILVER) 01-00066-006 <http://www.pdxrv.com/catalog/i2758.html>

BD2 (BROWN/GOLD) 01-00066-002 <http://www.pdxrv.com/catalog/i1363.html>

BD3 - Dual battery system, with cable and monitor panel with two on/off indicators, digital voltmeter, and ignition interlock relay.

BD3 (BLACK/SILVER) 01-00066-007 <http://www.pdxrv.com/catalog/i2759.html>

BD3 (BROWN/GOLD) 01-00066-003 <http://www.pdxrv.com/catalog/i1400.html>

Note: BD0 panel can be interchanged with BD, and BD2 can be interchanged with BD3

The dual relay panels include an ignition interlock relay that opens the power circuit to the chassis battery relay when the ignition is turned on, to prevent the battery from being accidentally opened when the engine is running.

A typical circuit is shown in FIGURE 5 and FIGURE 6. The switches are each double pole, double throw, momentary, center off. Operating the switch in either direction will cause the relays to open or close, depending on the polarity of the voltage applied.

FUSES

There are two 5 Amp fuses for the system, mounted on each relay. Looking at the relay with cap at the top, the fuse on the right feeds the LED indicator and, if so equipped, the digital voltmeter. The fuse on the left feeds the power to the switch that operates the solenoid.

BATTERY DISCONNECT

Trouble Shooting

Problem

House Relay won't engage, **BD0 & BD1 MODELS ONLY**

Possible Cause/Solution

STEP 1

Check fuses on relay. If not blown go to step 3, if blown replace with same size fuse and retest. If fuse / fuses re-blow go to step 2.

STEP 2

Disconnect harness from battery disconnect panel inside of RV, replace fuse, if fuse re-blows either attempt to find damage in the harness and repair or replace harness, (see PARTS LINK# 1 below). If fuse doesn't blow then go to step 3

PARTS LINK #1

BDO / BD1 HARNESS, 11-00063-000

Parts link: <http://www.pdxrv.com/catalog/i2756.html>

BD2 / BD2 HARNESS, 11-00139-000

Parts link: <http://www.pdxrv.com/catalog/i2761.html>

STEP 3

Check battery voltage, the voltage must be greater than 10.5 Volts DC for the latching relay to close or open. If batteries are below 10.5 Volts DC, charge batteries and retest. If the batteries are charged and are above 10.5 Volts DC go to step 4.

STEP 4

With an assistant, press and hold momentary switch, at the same time check for voltage across the coil terminals (+ on the "I" terminal and ground on the "S" terminal), **If 0 volts go to step 5. If voltage is 10.5 VDC or larger between the "I" & "S" terminals, replace relay.**

STEP 5

Remove battery disconnect panel from cabinet / console and with a multi-meter set on DC voltage, measure between the red wire at pin # 3 and the black wire on pin # 6. The voltage should read the same approximate value as the batteries. If not replace harness, refer to PARTS LINK#1. If the voltage reading is the same go to step 6.

STEP 6

With a multi-meter set on DC voltage, measure between the red wire at pin # 3 and the brown wire on pin # 1 while the switch is depressed. The voltage should read the same approximate value as the batteries. If not replace disconnect panel, refer to PARTS LINK # 2 (page 8). If the reading is the same go to step 7.

BATTERY DISCONNECT

Trouble Shooting

Problem

House Relay won't engage, **BD0 & BD1 MODELS ONLY**

PARTS LINK #2

Possible Cause/Solution

BD0 (BROWN/GOLD) 01-00066-000
Parts link: <http://www.pdxrv.com/catalog/i1399.html>
BD0 (BLACK/SILVER) 01-00066-004
Parts link: <http://www.pdxrv.com/catalog/i2755.html>
BD1 (BROWN/GOLD) 01-00066-001
Parts link: <http://www.pdxrv.com/catalog/i1364.html>
BD1 (BLACK/SILVER) 01-00066-005
Parts link: <http://www.pdxrv.com/catalog/i2757.html>
BD2 (BROWN/GOLD) 01-00066-002
Parts link: <http://www.pdxrv.com/catalog/i1363.html>
BD2 (BLACK/SILVER) 01-00066-006
Parts link: <http://www.pdxrv.com/catalog/i2758.html>
BD3 (BROWN/GOLD) 01-00066-003
Parts link: <http://www.pdxrv.com/catalog/i1400.html>
BD3 (BLACK/SILVER) 01-00066-007
Parts link: <http://www.pdxrv.com/catalog/i2759.html>

STEP 7

With a multi-meter set on DC voltage, measure between the black wire at pin # 6 and the white wire on pin # 4 while the switch is pressed. The voltage should read the same approximate value as the batteries. If not replace disconnect panel, refer to PARTS LINK # 2 (this page).

Trouble Shooting

Problem

House Relay won't disengage, **BD0 & BD1 MODELS ONLY**

STEP 8

Check fuses on relay. If not blown go to step 10, if blown replace with size fuse and retest. If fuse / fuses re-blow go to step 9.

STEP 9

Disconnect harness from battery disconnect panel inside of RV, replace fuse, if fuse re-blows either attempt to find damage in the harness and repair or replace harness, (see P# 1 link page 7). If fuse doesn't blow then go to step 10.

STEP 10

Check battery voltage, the voltage must be greater than 10.5 Volts DC for the latching relay to close or open. If batteries are below 10.5 Volts DC, charge batteries and retest. If the batteries are charged and are above 10.5 Volts DC go to step 11.

BATTERY DISCONNECT

Trouble Shooting Problem

House Relay won't disengage, **BD0 & BD1 MODELS ONLY**

Possible Cause/Solution

STEP 11

With an assistant, press and hold momentary switch, at the same time check for voltage across the coil terminals (+ on the "S" terminal and ground on the "I" terminal), **If 0 volts go to step 12. If voltage is 10.5 VDC or larger between the "S" & "I" terminals, replace relay.**

STEP 12

Remove battery disconnect panel from cabinet / console and with a multi-meter set on DC voltage, measure between the red wire at pin # 3 and the black wire on pin # 6. The voltage should read the same approximate value as the batteries. If not replace harness, refer to PARTS LINK#1 (page 7). If the voltage reading is the same go to step 13.

STEP 13

With a multi-meter set on DC voltage, measure between the red wire at pin # 3 and the white wire on pin #4 while the switch is depressed. The voltage should read the same approximate value as the batteries. If not replace disconnect panel, refer to PARTS LINK # 2 (page 7). If the reading is the same go to step 14.

STEP 14

With a multi-meter set on DC voltage, measure between the black wire at pin # 6 and the brown wire on pin # 1 while the switch is pressed. The voltage should read the same approximate value as the batteries. If not replace disconnect panel, refer to PARTS LINK # 2 (page 7).

Trouble Shooting Problem

House indicator light on panel remains on although relay is off. **BD0 & BD1 MODELS ONLY**

Possible Cause/Solution

STEP 15

Is coach plugged in, unplug coach and retest
Is engine running, turn engine off and retest
If the panel fails one or both retests then go to step 16.

BATTERY DISCONNECT

Trouble Shooting

Problem

House indicator light on panel remains on although relay is off. **BD0 & BD1 MODELS ONLY**

STEP 16

Possible Cause/Solution

Verify that the relay is actually in the disengaged (unlatched) state. With a test light, probe the larger 5/16" stud terminals on each side of the relay. Only one terminal should be powered up in the disengaged state. If both studs are powering up the test light go to step 8. If only one 5/16" terminal is powered up go to step 17

STEP 17

Remove the battery disconnect panel from cabinet / console and with a multi-meter set on DC voltage, measure between the green wire at pin # 5 and the black wire on pin # 6. The voltage should read 0 Volts DC. If it reads 0 VDC then replace switch panel, refer to PARTS LINK #2 (page 8). If the voltage reading is the same as the nominal battery reading then go to step 18.

STEP 18

Disconnect the plug from the battery disconnect panel, with a multi-meter set on DC voltage, measure between the green wire at pin # 5 and the black wire on pin # 6. The voltage continues to read 12 Volts DC go to step 19. If it now reads 0 VDC then replace switch panel, refer to PARTS LINK #2 (page 8).

STEP 19

Leave the battery disconnect switch unplugged. At the relay location, disconnect the green wire from the relay. With a test light, probe the fuse for voltage. If the test light powers up, replace the relay and retest. If it does not, then probe the green wire. If there is voltage present replace the harness, refer to PARTS LINK #1 (page 7)

Trouble Shooting

Problem

House indicator light is off although relay is on (latched). **BD0 & BD1 MODELS ONLY**

STEP 20

Possible Cause/Solution

Verify that the relay is actually in the engaged (latched) state. With a test light, probe the larger 5/16" stud terminals on each side of the relay. Both terminals should be powered up in the engaged (latched) state. If only one is powering up the test light go to step 1. If both 5/16" terminals are powered up go to step 21.

BATTERY DISCONNECT

Trouble Shooting

Problem

House indicator light is off although relay is on (latched). **BD0 & BD1 MODELS ONLY**

STEP 21

Possible Cause/Solution

Check fuses on relay. If not blown go to step 22, if blown replace with size fuse and retest. If fuse / fuses re-blow go to step 9.

STEP 22

Remove the battery disconnect panel from cabinet / console and with a multi-meter set on DC voltage, measure between the green wire at pin # 5 and the black wire on pin # 6. The voltage should read whatever DC voltage as the batteries read (typically around 12 volts). If it reads 0 VDC then inspect the harness for damage, or replace harness, refer to PARTS LINK #1 (page 7). If the voltage reading is the same as the nominal battery reading then replace battery disconnect panel, refer to PARTS LINK #2 (page 8)

Trouble Shooting

Problem

House Relay won't engage, **BD2 & BD3 MODELS ONLY**

STEP 23

Possible Cause/Solution

Check fuses on house relay. If not blown go to step 25, if blown replace with size fuse and retest. If fuse / fuses re-blow go to step 24.

STEP 24

Disconnect harness from battery disconnect panel inside of RV, replace fuse, if fuse re-blows either attempt to find damage in the harness and repair or replace harness, (see PARTS LINK# 1 page 7). If fuse doesn't blow then go to step 25.

STEP 25

Check battery voltage, the voltage must be greater than 10.5 Volts DC for the latching relay to close or open. If batteries are below 10.5 Volts DC, charge batteries and retest. If the batteries are charged and are above 10.5 Volts DC go to step 26.

STEP 26

With an assistant, press and hold momentary switch, at the same time check for voltage across the coil terminals (+ on the "I" terminal and ground on the "S" terminal), **If 0 volts go to step 27. If voltage is 10.5 VDC or larger between the "I" & "S" terminals, replace house relay.**

BATTERY DISCONNECT

Trouble Shooting

Problem

House Relay won't engage, **BD2 & BD3 MODELS ONLY**

STEP 27

Possible Cause/Solution

Remove battery disconnect panel from cabinet / console and with a multi-meter set on DC voltage, measure between the red wire at pin # 2 and the black wire on pin # 12. The voltage should read the same approximate value as the batteries. If not replace harness, refer to PARTS LINK#1 (page 7). If the voltage reading is the same go to step 28.

STEP 28

With a multi-meter set on DC voltage, measure between the red wire at pin # 2 and the brown wire on pin # 1 while the switch is depressed. The voltage should read the same approximate value as the batteries. If not replace disconnect panel, refer to PARTS LINK # 2 (next page8). If the reading is the same go to step 29.

STEP 29

With a multi-meter set on DC voltage, measure between the black wire at pin # 12 and the white wire on pin # 4 while the switch is pressed. The voltage should read the same approximate value as the batteries. If not replace disconnect panel, refer to PARTS LINK # 2 (page 8).

Trouble Shooting

Problem

House Relay won't disengage, **BD2 & BD3 MODELS ONLY**

STEP 30

Possible Cause/Solution

Check fuses on relay. If not blown go to step 32, if blown replace with size fuse and retest. If fuse / fuses re-blow go to step 31.

STEP 31

Disconnect harness from battery disconnect panel inside of RV, replace fuse, if fuse re-blows either attempt to find damage in the harness and repair or replace harness, (see P# 1 link page 7). If fuse doesn't blow then go to step 32.

STEP 32

Check battery voltage, the voltage must be greater than 10.5 Volts DC for the latching relay to close or open. If batteries are below 10.5 Volts DC, charge batteries and retest. If the batteries are charged and are above 10.5 Volts DC go to step33.

BATTERY DISCONNECT

Trouble Shooting Problem

House Relay won't disengage, **BD2 & BD3 MODELS ONLY**

Possible Cause/Solution

STEP 33

With an assistant, press and hold momentary switch, at the same time check for voltage across the coil terminals (+ on the "S" terminal and ground on the "I" terminal), **If 0 volts go to step 34. If voltage is 10.5 VDC or larger between the "S" & "I" terminals, replace house relay.**

STEP 34

Remove battery disconnect panel from cabinet / console and with a multi-meter set on DC voltage, measure between the red wire at pin # 2 and the black wire on pin # 12. The voltage should read the same approximate value as the batteries. If not replace harness, refer to PARTS LINK#1 (page 7). If the voltage reading is the same go to step 35.

STEP 35

With a multi-meter set on DC voltage, measure between the red wire at pin # 2 and the white wire on pin #4 while the switch is depressed. The voltage should read the same approximate value as the batteries. If not replace disconnect panel, refer to PARTS LINK # 2 (page 7). If the reading is the same go to step 36.

STEP 36

With a multi-meter set on DC voltage, measure between the black wire at pin # 12 and the brown wire on pin # 1 while the switch is pressed. The voltage should read the same approximate value as the batteries. If not replace disconnect panel, refer to PARTS LINK # 2 (page 7).

Trouble Shooting Problem

House indicator light on panel remains on although relay is off. **BD2 & BD3 MODELS ONLY**

Possible Cause/Solution

STEP 37

Is coach plugged in, unplug coach and retest
Is engine running, turn engine off and retest
If the panel fails one or both retests then go to step 38.

BATTERY DISCONNECT

Trouble Shooting Problem

House indicator light on panel remains on although relay is off. **BD2 & BD3 MODELS ONLY**

Possible Cause / Solution

STEP 38

Verify that the relay is actually in the disengaged (unlatched) state. With a test light, probe the larger 5/16" stud terminals on each side of the relay. Only one terminal should be powered up in the disengaged state. If both studs are powering up the test light go to step 8. If only one 5/16" terminal is powered up go to step 39.

STEP 39

Remove the battery disconnect panel from cabinet / console and with a multi-meter set on DC voltage, measure between the green wire at pin # 10 and the black wire on pin # 12. The voltage should read 0 Volts DC. If it reads 0 VDC then replace switch panel, refer to PARTS LINK #2 (page 8). If the voltage reading is the same as the nominal battery reading then go to step 40.

STEP 40

Disconnect the plug from the battery disconnect panel, with a multi-meter set on DC voltage, measure between the green wire at pin # 10 and the black wire on pin # 12. The voltage continues to read 12 Volts DC go to step 41. If it now reads 0 VDC then replace switch panel, refer to PARTS LINK #2 (page 8).

STEP 41

Leave the battery disconnect switch unplugged. At the relay location, disconnect the green wire from the relay. With a test light, probe the fuse for voltage. If the test light powers up, replace the relay and retest. If it does not, then probe the green wire. If there is voltage present replace the harness, refer to PARTS LINK #1 (page 7)

BATTERY DISCONNECT

Trouble Shooting Problem

House indicator light is off although relay is on (latched). **BD2 & BD3 MODELS ONLY**

STEP 42

Possible Cause / Solution

Verify that the relay is actually in the engaged (latched) state. With a test light, probe the larger 5/16" stud terminals on each side of the relay. Both terminals should be powered up in the engaged (latched) state. If only one is powering up the test light go to step 1. If both 5/16" terminals are powered up go to step 43.

STEP 43

Check fuses on relay. If not blown go to step 44, if blown replace with size fuse and retest. If fuse / fuses re-blow go to step 9.

STEP 44

Remove the battery disconnect panel from cabinet / console and with a multi-meter set on DC voltage, measure between the green wire at pin # 5 and the black wire on pin # 6. The voltage should read whatever DC voltage as the batteries read (typically around 12 volts). If it reads 0 VDC then inspect the harness for damage, or replace harness, refer to PARTS LINK #1 (page 7). If the voltage reading is the same as the nominal battery reading then replace battery disconnect panel, refer to PARTS LINK #2 (page 8)

Trouble Shooting Problem

Chassis Relay won't engage (latch), **BD2 & BD3 MODELS ONLY**

STEP 45

Possible Cause / Solution

Check fuses on chassis relay. If not blown go to step 47, if blown replace with same size fuse and retest. If fuse / fuses re-blow go to step 46.

STEP 46

Disconnect harness from battery disconnect panel inside of RV, replace fuse, if fuse re-blows either attempt to find damage in the harness and repair or replace harness, (see PARTS LINK# 1 page 7). If fuse doesn't blow then go to step 47.

BATTERY DISCONNECT

Trouble Shooting Problem

Chassis Relay won't engage (latch), **BD2 & BD3 MODELS ONLY**

Possible Cause / Solution

STEP 47

Check battery voltage, the voltage must be greater than 10.5 Volts DC for the latching relay to close or open. If batteries are below 10.5 Volts DC, charge batteries and retest. If the batteries are charged and are above 10.5 Volts DC go to step 48.

STEP 48

With an assistant, press and hold momentary switch, at the same time check for voltage across the coil terminals of the chassis battery relay(+ on the "I" terminal and ground on the "S" terminal), **If 0 volts go to step 49. If voltage is 10.5 VDC or larger between the "I" & "S" terminals, replace chassis relay.**

STEP 49

Remove battery disconnect panel from cabinet / console and with a multi-meter set on DC voltage, measure between the orange wire at pin # 7 and the black wire on pin # 12. The voltage should read the same approximate value as the batteries. If not replace harness, refer to PARTS LINK#1 (page 7). If the voltage reading is the same go to step 50.

STEP 50

With a multi-meter set on DC voltage, measure between the orange wire at pin # 7 and the gray wire on pin # 8 while the switch is depressed. The voltage should read the same approximate value as the batteries. If not replace disconnect panel, refer to PARTS LINK # 2 (page8). If the reading is the same go to step 51.

STEP 51

With a multi-meter set on DC voltage, measure between the black wire at pin # 12 and the violet wire on pin # 6 while the switch is pressed. The voltage should read the same approximate value as the batteries. If not replace disconnect panel, refer to PARTS LINK # 2 (page 8).

BATTERY DISCONNECT

Trouble Shooting Problem

Chassis Relay won't disengage (unlatch),
BD2 & BD3 MODELS ONLY

Possible Cause / Solution

STEP 52

NOTE: The BD2 & BD3 panels have an interlock that will not allow chassis battery bank to be “unlatched” while ignition is on. This feature should not be defeated as high voltages from the alternator can damage sensitive electronics. If engine running / ignition is on, turn engine off / switch off ignition and retest. If the panel fails retests then go to step 53.

STEP 53

Check fuses on relay. If not blown go to step 54, if blown replace with same size fuse and retest. If fuse / fuses re-blow go to step 54.

STEP 54

Disconnect harness from battery disconnect panel inside of RV, replace fuse, if fuse re-blows either attempt to find damage in the harness and repair or replace harness, (see P# 1 link page 7). If fuse doesn't blow then go to step 55.

STEP 55

Check battery voltage, the voltage must be greater than 10.5 Volts DC for the latching relay to close or open. If batteries are below 10.5 Volts DC, charge batteries and retest. If the batteries are charged and are above 10.5 Volts DC go to step 56.

STEP 56

Remove battery disconnect panel from cabinet / console and with a multi-meter set on DC voltage, measure between the blue wire at pin # 5 and the black wire on pin # 12. The voltage should read 0 VDC, if your reading a voltage of 10.5 VDC or greater go to step 57. If the voltage reading is 0 VDC then go to step 58.

STEP 57

NOTE: The BD2 & BD3 panels have an interlock that will not allow the chassis battery bank to be “unlatched” while ignition is on. Disconnect the plug from the battery disconnect panel, re-measure between the blue wire and the black wire. If there is no voltage, replace the battery disconnect panel, refer to PARTS LINK # 2 (page 8). If there is voltage on the blue wire, TBSH the ignition circuit as the ignition circuit is still on and is not being controlled by the ignition switch.

BATTERY DISCONNECT

Trouble Shooting Problem

Chassis Relay won't disengage (unlatch),
**BD2 & BD3
MODELS ONLY**

STEP 58

Possible Cause / Solution

With an assistant, press and hold momentary switch, at the same time check for voltage across the coil terminals (+ on the "S" terminal and ground on the "I" terminal), **If 0 volts go to step 59. If voltage is 10.5 VDC or larger between the "S" & "I" terminals, replace chassis relay.**

STEP 59

Remove battery disconnect panel from cabinet / console and with a multi-meter set on DC voltage, measure between the orange wire at pin # 7 and the black wire on pin # 12. The voltage should read the same approximate value as the batteries. If not replace harness, refer to PARTS LINK#1 (page 7). If the voltage reading is the same go to step 60.

STEP 60

With a multi-meter set on DC voltage, measure between the orange wire at pin # 7 and the violet wire on pin #6 while the switch is depressed. The voltage should read the same approximate value as the batteries. If not replace disconnect panel, refer to PARTS LINK # 2 (page 7). If the reading is the same go to step 61.

STEP 61

With a multi-meter set on DC voltage, measure between the black wire at pin # 12 and the gray wire on pin # 8 while the switch is pressed. The voltage should read the same approximate value as the batteries. If not replace disconnect panel, refer to PARTS LINK # 2 (page 7).

Trouble Shooting Problem

Chassis indicator light on panel remains on, although relay is off. **BD2 & BD3
MODELS ONLY**

STEP 62

Possible Cause / Solution

Is engine running / ignition switch on, turn engine off and retest
If the panel fails retests then go to step 63.

BATTERY DISCONNECT

Trouble Shooting Problem

Chassis indicator light on panel remains on, although relay is off. **BD2 & BD3 MODELS ONLY**

STEP 63

Possible Cause / Solution

Verify that the relay is actually in the disengaged (unlatched) state. With a test light, probe the larger 5/16" stud terminals on each side of the relay. Only one terminal should be powered up in the disengaged state. If both studs are powering up the test light go to step 52. If only one 5/16" terminal is powered up go to step 64.

STEP 64

Remove the battery disconnect panel from cabinet / console and with a multi-meter set on DC voltage, measure between the yellow wire at pin # 11 and the black wire on pin # 12. The voltage should read 0 Volts DC. If it reads 0 VDC then replace switch panel, refer to PARTS LINK #2 (page 8). If the voltage reading is the same as the nominal battery reading then go to step 65.

STEP 65

Disconnect the plug from the battery disconnect panel, with a multi-meter set on DC voltage, measure between the yellow wire at pin # 11 and the black wire on pin # 12. If the voltage continues to read 12 Volts DC go to step 41. If it now reads 0 VDC then replace switch panel, refer to PARTS LINK #2 (page 8).

STEP 66

Leave the battery disconnect switch unplugged. At the relay location, disconnect the yellow wire from the relay. With a test light, probe the fuse for voltage. If the test light powers up, replace the relay and retest. If it does not, then probe the green wire. If there is voltage present replace the harness, refer to PARTS LINK #1 (page 7)

Trouble Shooting Problem

Chassis indicator light is off although relay is on (latched). **BD2 & BD3 MODELS ONLY**

STEP 67

Possible Cause / Solution

Verify that the relay is actually in the engaged (latched) state. With a test light, probe the larger 5/16" stud terminals on each side of the relay. Both terminals should be powered up in the engaged (latched) state. If only one is powering up the test light go to step 45. If both 5/16" terminals are powered up go to step 68.

BATTERY DISCONNECT

Trouble Shooting Problem

Chassis indicator light is off although relay is on (latched). **BD2 & BD3 MODELS ONLY**

STEP 67

Possible Cause / Solution

Check fuses on chassis relay. If not blown go to step 68, if blown replace with size fuse and retest. If fuse / fuses re-blow go to step 9.

STEP 68

Remove the battery disconnect panel from cabinet / console and with a multi-meter set on DC voltage, measure between the yellow wire at pin # 11 and the black wire on pin # 6. The voltage should read whatever DC voltage as the batteries read (typically around 12 volts). If it reads 0 VDC then inspect the harness for damage, or replace harness, refer to PARTS LINK #1 (page 7). If the voltage reading is the same as the nominal battery reading then replace battery disconnect panel, refer to PARTS LINK #2 (page 8)

Trouble Shooting Problem

No voltmeter reading on battery disconnect panel display panel. **BD3 MODEL ONLY**

STEP 68

Possible Cause / Solution

Check fuse on house relay that attaches to the green wire. If not blown go to step 69, if blown replace with size fuse and retest. If fuse / fuses re-blow go to step 9.

STEP 69

Remove the battery disconnect panel from cabinet / console and with a multi-meter set on DC voltage, measure between the green wire at pin # 5 and the black wire on pin # 6. The voltage should read whatever DC voltage as the batteries read (typically around 12 volts). If it reads 0 VDC then inspect the harness for damage, or replace harness, refer to PARTS LINK #1 (page 7). If the voltage reading is the same as the nominal battery reading then replace battery disconnect panel, refer to PARTS LINK #2 (page 8)

BATTERY DISCONNECT

Trouble Shooting Problem

No voltmeter reading on battery disconnect panel display panel (Read Volts Coach). **BD3 MODEL ONLY**

STEP 69

Possible Cause / Solution

Check fuse on house relay that attaches to the green wire. If not blown go to step 70, if blown replace with size fuse and retest. If fuse / fuses re-blow go to step 9.

STEP 70

Remove the battery disconnect panel from cabinet / console and with a multi-meter set on DC voltage, measure between the green wire at pin # 10 and the black wire on pin # 12. The voltage should read whatever DC voltage as the batteries read (typically around 12 volts). If it reads 0 VDC then inspect the harness for damage, or replace harness, refer to PARTS LINK #1 (page 7). If the voltage reading is the same as the nominal battery reading then replace battery disconnect panel, refer to PARTS LINK #2 (page 8)

Trouble Shooting Problem

No voltmeter reading on battery disconnect panel display panel (Read Volts Chassis). **BD3 MODEL ONLY**

STEP 71

Possible Cause / Solution

Check fuse on chassis relay that attaches to the yellow wire. If not blown go to step 70, if blown replace with size fuse and retest. If fuse / fuses re-blow go to step 9.

STEP 72

Remove the battery disconnect panel from cabinet / console and with a multi-meter set on DC voltage, measure between the yellow wire at pin # 11 and the black wire on pin # 12. The voltage should read whatever DC voltage as the batteries read (typically around 12 volts). If it reads 0 VDC then inspect the harness for damage, or replace harness, refer to PARTS LINK #1 (page 7). If the voltage reading is the same as the nominal battery reading then replace battery disconnect panel, refer to PARTS LINK #2 (page 8)

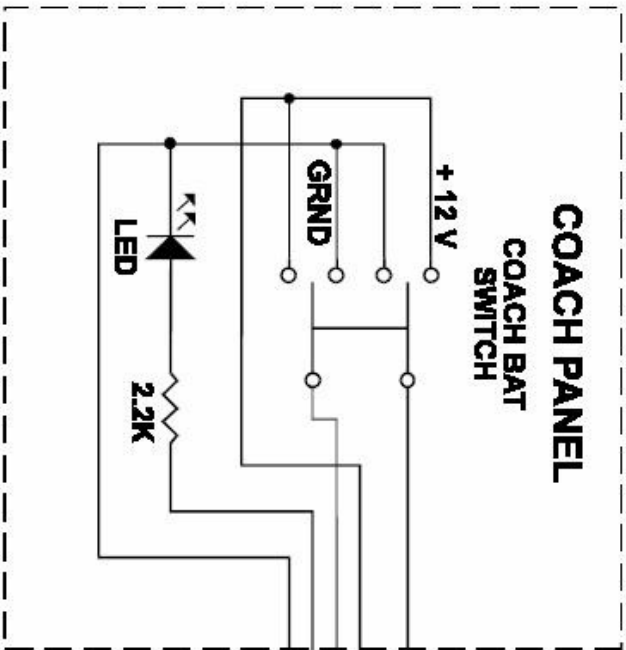

**NOTE: MOVE SWITCH
DOWN FOR USE
UP FOR STORE**

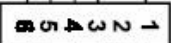

INTER-CONNECT CABLE

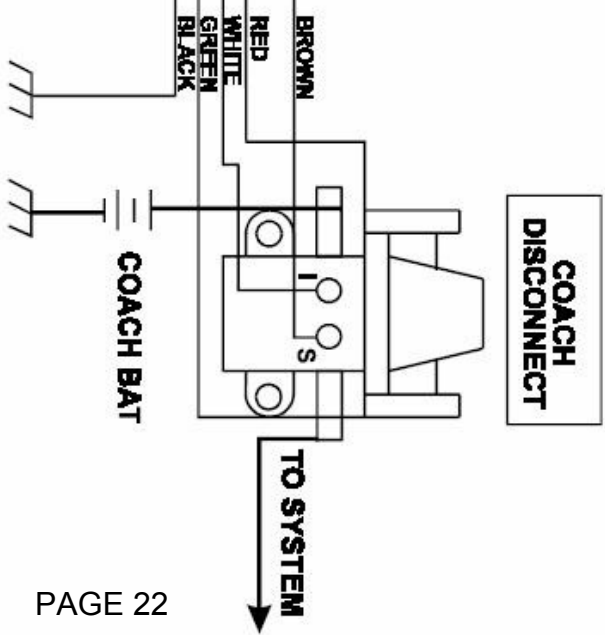

**NOTE: "I" TERMINAL + FOR USE
"S" TERMINAL + FOR STORE**

**SINGLE BATTERY DISCONNECT
MODELS BD0 & BD1**

COACH PANEL

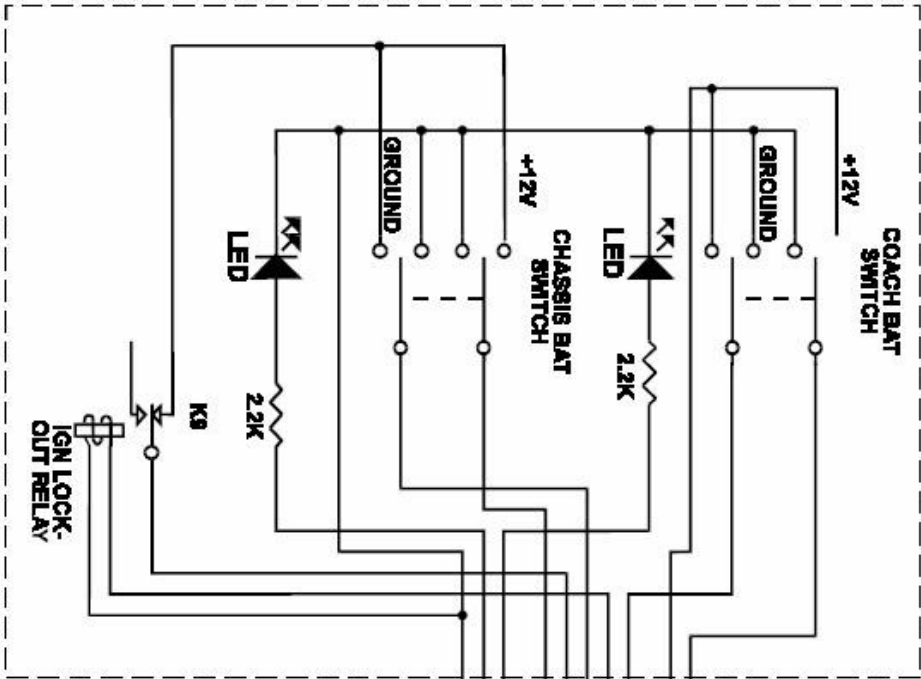

NOTE: MOVE SWITCHES
DOWN FOR USE
UP FOR STORE

DUAL BATTERY DISCONNECT

MODELS BD2 & BD3

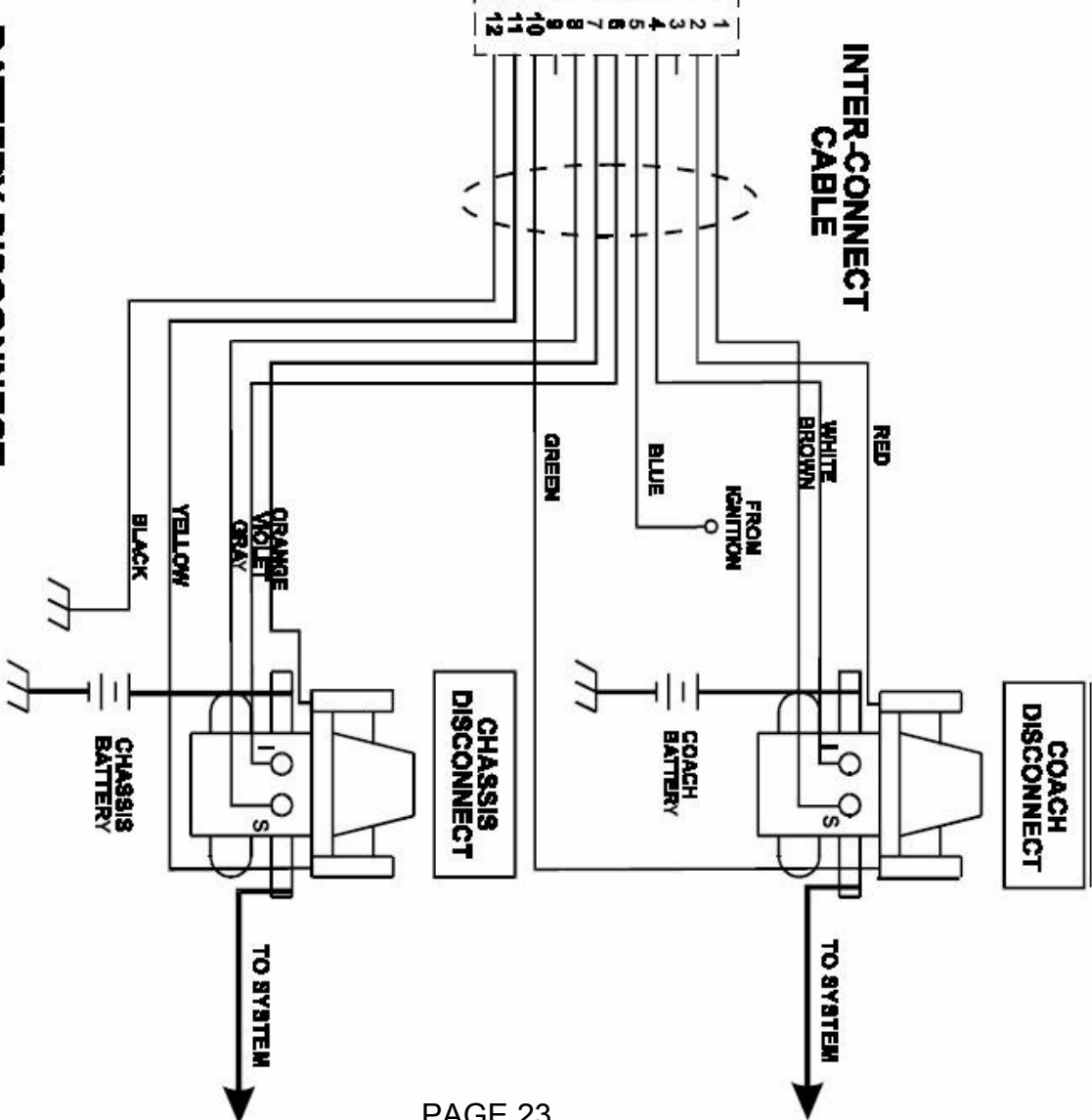

NOTE: "1" TERMINAL + FOR USE
"8" TERMINAL + FOR STORE