



## USER'S INFORMATION MANUAL For Model P-40

This book contains instructions covering the operation and maintenance of your furnace. Keep with unit at all times.

Should you require further information, contact your dealer or nearest Suburban Service Center.

**WARNING!** Installation of this appliance must be made in accordance with the written instructions provided in this manual. No agent, representative or employee of Suburban or other person has the authority to change, modify or waive any provision of the instructions contained in this manual.

**WARNING!** Improper installation, adjustment, alteration, service or maintenance can cause property damage, personal injury or loss of life. Refer to the installation instructions and/or owners manual provided with this appliance.

### MAINTENANCE AND CLEANING

**WARNING!** If the user of this appliance fails to maintain it in the condition in which it was shipped from the factory or if the appliance is not used solely for its intended purpose or if appliance is not maintained in accordance with the instructions in this manual, then the risk of a fire and/or the production of carbon monoxide exists which can cause personal injury, property damage or loss of life.

**CAUTION:** Label all wires prior to disconnection when servicing controls. Wiring errors can cause improper and dangerous furnace operation.

Always verify proper operation of furnace after servicing.

You, as the owner/user, should inspect the furnace monthly during the heating season for presence of soot on vent. Operating the furnace under this condition could lead to serious property damage, personal injury or loss of life. If soot is observed on the vent, immediately shut furnace down and contact a qualified service agency.

**WARNING!** Be sure the furnace and all ignition systems are "OFF" during any type of refueling and while vehicle is in motion or being towed.

**WARNING:** If the information in this manual is not followed exactly, a fire or explosion may result causing property damage, personal injury or loss of life.

Do not store or use gasoline or other flammable vapors and liquids in the vicinity of this or any other appliance.

#### WHAT TO DO IF YOU SMELL GAS

- Extinguish any open flame.
- Evacuate all persons from the vehicle.
- Shut off the gas supply at the gas container or source.
- Do not touch any electrical switch, or use any phone or radio in the vehicle.
- Do not start the vehicle's engine or electric generator.
- Contact the nearest gas supplier or qualified service technician for repairs.
- If you cannot reach a gas supplier or qualified service technician, contact the nearest fire department.
- Do not turn on the gas supply until the gas leak(s) has been repaired.

Installation and service must be performed by a qualified installer, service agency or the gas supplier.

Listed below are several safety related items that you should follow during the heating season to assure continued safe operation of the France.

1. Inspect furnace venting. Venting must be free of obstructions, void of soot and properly terminated to the atmosphere. (Refer to Installation Manual.)

**WARNING!** Do not install screens over the vent for any reason. Screens will become restricted and cause unsafe furnace operation. Accessories are being marketed for RV products which we do not recommend. For your safety, only factory authorized parts are to be used on your furnace.

2. Periodically inspect the vent for obstructions or presence of soot. Soot is formed whenever combustion is incomplete. This is your visual warning that the furnace is operating in an unsafe manner. If soot is present, immediately shut furnace down and contact your dealer or a qualified service person.

3. Periodically observe the main burner flame to assure it is burning with a hard blue flame with well defined burner ports (See Figure 2). If flame appears yellow or burner has a lazy flame, shut furnace down. It is possible that burner needs cleaning or replaced. To inspect the main burner, remove the four (4) screws (A, B, C and D) securing the burner access door to the combustion chamber (See Figure 1). If excessive rust and corrosion are present on burner surface, the burner must be thoroughly cleaned or replaced. The burner may be cleaned using a steel wire brush and blown clean using high compression air. Contact a qualified service person for assistance.

NOTE: To observe flame, cabinet front must be removed. Operation of burner can then be observed through the viewing window on front of chamber (See Figure 1).

4. Keep furnace clean. More frequent cleaning may be required due to excessive lint from carpeting, bedding material, etc. It is imperative that control compartments, burners and circulating air passageways of the appliance be kept clean.

5. The motor is permanently lubricated and requires no oiling.

6. Keep the furnace area clear of any combustible materials, gasoline or other flammable vapor and liquids.

7. Before operating furnace, check the location of the furnace vent to make sure it will not be blocked by the opening of any door on the trailer. If it can be blocked, do not operate the furnace with the door open.

8. Do not restrict the flow of combustion air or the warm air circulation to the furnace. To do so could cause personal injury and/or death.

9. Never operate the furnace if you smell gas. Do not assume that the smell of gas in your RV is normal. Any time you detect the odor of gas, it is to be considered life threatening and corrected immediately. Extinguish any open flames including cigarettes and evacuate all persons from the vehicle. Shut off gas supply at LP gas bottle. (See safety notice on front cover of this manual.)

10. Immediately shut furnace down and call a service agency if furnace cycles erratically or delays on ignition.

**WARNING! Should overheating occur, or the gas supply fail to shut off, shut off the manual gas valve to the appliance before shutting off the electrical supply.**

11. Never attempt to repair damaged parts. Always have them replaced by a qualified service agency.

12. Never attempt to repair the furnace yourself. Seek the help of a qualified service person.

13. Never restrict the ducting installed by your trailer manufacturer. To do so could cause improper furnace operation.

14. Do not install air boosters in the duct system. Such devices will cause the furnace to cycle on limit and to have erratic sail switch operation.

15. Clothing or other flammable material should not be placed on or near the appliance.

16. Always follow the Operating Instructions. Do not deviate from the step-by-step procedures.

17. Do not use this appliance if any part has been submerged under water. Immediately call a qualified service technician to inspect the appliance and to replace any part of the control system and any gas control that has been submerged under water.

18. When considering add-on rooms, porch or patio, attention must be given to the venting of your furnace. For your safety, do not terminate furnace vent inside add-on rooms, screen porch or onto patios. Doing so will result in products of combustion being vented into the room or occupied areas.

19. In any installation in which the vent of this appliance can be covered due to the construction of the RV or some special feature of the RV such as slide out, pop-up etc. always insure that the appliance cannot be operated by setting the thermostat to the positive "OFF" position and shutting off all electrical and gas supply to the appliance. Never operate furnace with vent covered.

**Your furnace should be inspected by a qualified service agency yearly before turning the furnace on. Particular attention should be given to the following items.**

1. Inspect furnace installation and vent termination to be sure furnace is properly secured in place, that vent terminates to the atmosphere and that vent tubes overlap properly. (See installation manual supplied with furnace.)

2. Inspect chamber and venting to assure that these components are physically sound, without holes or excessive corrosion and that the installation and/or reinstallation is in accordance with Suburban's Installation Instructions. (Reference installation manual supplied with furnace.)

**WARNING! It is imperative that the products of combustion be properly vented to atmosphere and that all combustion air supplied to burner be drawn from outside atmosphere.**

3. Check the base on which furnace is mounted. Be sure it is physically sound, void of any sagging, deterioration, etc.

4. Inspect furnace, the venting, ducting and the gas piping to furnace for obvious signs of deterioration. Correct any defects at once.

5. Inspect combustion chamber for restrictions in exhaust or intake. It is imperative that the flow of intake combustion air and the flow of exhaust gases being expelled to the outside atmosphere not be obstructed. Any soot or loose debris should be blown out using compressed air. (See Figure 3.)

6. Inspect all gaskets. If any gaskets show signs of leakage or deterioration, replace them. Safe operation of the furnace depends on all gaskets being tight.

7. Inspect return air inlet openings to the furnace. Remove any restrictions to assure adequate air flow.

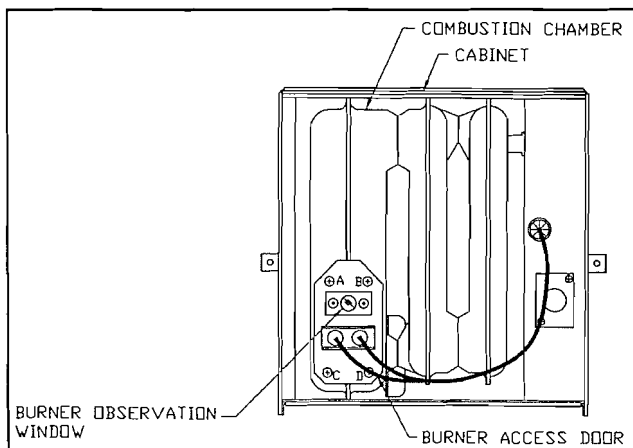

Figure 1

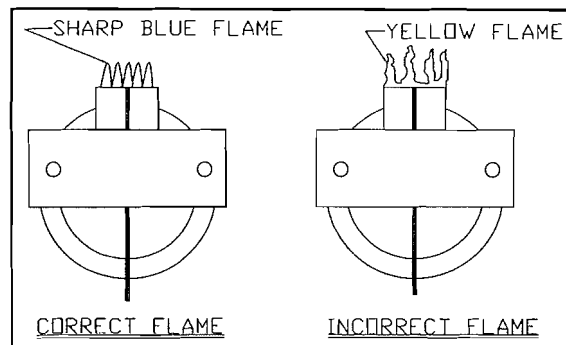
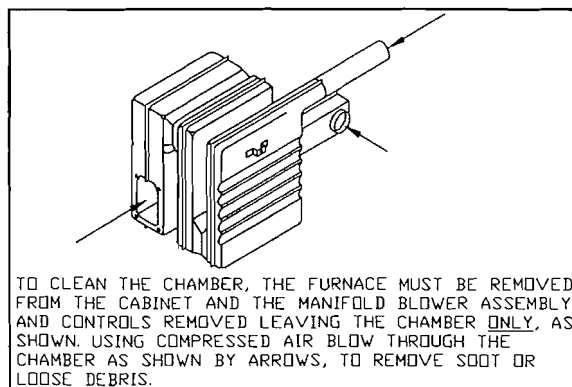

Figure 2



TO CLEAN THE CHAMBER, THE FURNACE MUST BE REMOVED FROM THE CABINET AND THE MANIFOLD BLOWER ASSEMBLY AND CONTROLS REMOVED LEAVING THE CHAMBER ONLY, AS SHOWN. USING COMPRESSED AIR BLOW THROUGH THE CHAMBER AS SHOWN BY ARROWS, TO REMOVE SOOT OR LOOSE DEBRIS.

Figure 3

## OPERATING INSTRUCTIONS

**WARNING! Do not operate furnace while vehicle is in motion or being towed.**

NOTE: During initial firing of this furnace a burn-off of excess paint and oils remaining from manufacturing process may cause "smoking" for 5 - 10 minutes.

## FOR YOUR SAFETY READ BEFORE OPERATING

**WARNING: If you do not follow these instructions exactly, a fire or explosion may result causing property damage, personal injury or loss of life.**

- A. This appliance does not have a pilot. It is equipped with an ignition device which automatically lights the burner. Do not light the burner by hand.
- B. BEFORE OPERATING smell all around the appliance area for gas. Be sure to smell next to the floor because some gas is heavier than air and will settle on the floor.

### WHAT TO DO IF YOU SMELL GAS

- Extinguish any open flame.
- Evacuate all persons from the vehicle.
- Shut off the gas supply at the gas container or source.
- Do not touch any electric switch or use any phone or radio in the vehicle.
- Do not start the vehicle's engine or electric generator.

- Contact the nearest gas supplier or qualified service technician for repairs.
  - If you cannot reach a gas supplier or qualified service technician, contact the nearest fire department.
  - Do not turn on the gas supply until the gas leak(s) has been repaired.
- C. Use only your hand to push in or turn the gas control knob. Never use tools. If the knob will not push in or turn by hand, don't try to repair it, call a qualified service technician. Force or attempted repair may result in a fire or explosion.
- D. Do not use this appliance if any part has been under water. Immediately call a qualified service technician to inspect the appliance and to replace any part of the control system and any gas control which has been under water.

## OPERATING INSTRUCTIONS

1. STOP! Read Users Information Manual supplied with furnace.
2. Turn the manual valve or the valve at the outside LP tank to the "OFF" position. Do not force.

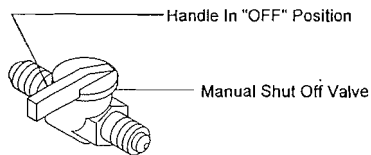

Valve shown in "OFF" position.

3. Set thermostat above room temperature to begin blower operation. A slight delay will occur before the blower comes on. Allow blower to run for 5 minutes for combustion chamber purge cycle.

4. After 5 minutes, move thermostat lever below room temperature. Blower will remain on. Wait approximately 2 minutes for blower to go off.
5. Wait five (5) minutes to clear out any gas. Then smell for gas including near the floor. If you then smell gas, STOP! Follow "B" in the safety information above on this label. If you don't smell gas, go to next step.
6. Open manual shut-off valve or the valve at the outside LP tank. Correct operating characteristics depend on the valve being positioned fully open. Never attempt to operate with a valve partially closed.
7. Set thermostat lever to desired setting. If set above room temperature, blower will come on.
8. Allow 30 seconds for main burner to light after blower comes on. This furnace is equipped with an ignition device which automatically lights the burner. Do not try to light the burner by hand.
9. If burner does not light, repeat Steps 1 through 9.
10. If after three (3) attempts with no ignition, go to shut down and contact your dealer or a local recreational vehicle service agency. Do not continue to cycle furnace through thermostat in an attempt to get ignition.

## TO TURN OFF GAS TO APPLIANCE

1. Set the thermostat to lowest setting, then move lever to "OFF" position.
2. Turn off all electric power to the appliance if service is to be performed.
3. Turn shut-off valve clockwise → to "OFF". Do not force.

# TWO YEAR LIMITED WARRANTY

## SUBURBAN RECREATIONAL VEHICLE FURNACE

### TWO YEAR LIMITED WARRANTY

This Suburban product is warranted to the original purchaser to be free from defects in material and workmanship under normal use and maintenance for a period of two years from date of purchase whether or not actual use begins on that date. It is the responsibility of the consumer/owner to establish the warranty period. Suburban does not use warranty registration cards for its standard warranty. You are required to furnish proof of purchase date through a Bill of Sale or other payment record.

Suburban will replace any parts that are found defective within the first two years and will pay a warranty service allowance directly to the authorized Suburban Service Center at rates mutually agreed upon between Suburban and its authorized service centers. Replacement parts will be shipped FOB the shipping point within the Continental United States, Alaska and Canada to authorized service centers performing such repairs. Before having warranty repairs made, confirm that the service agency is an authorized service center for Suburban. DO NOT PAY THE SERVICE AGENCY FOR WARRANTY REPAIRS; SUCH PAYMENTS WILL NOT BE REIMBURSED.

For warranty service, the owner/user should contact the nearest authorized Suburban Service Center, advising them of the model and serial numbers (located on the furnace) and the nature of the defect. Transportation of the unit to and from the Service Center and/or travel expenses of the Service Center to your location is the responsibility of the owner/user. A listing of authorized Service Centers is included in the owner's packet supplied with the furnace and a current listing may be obtained from Suburban. If you cannot locate an authorized service center locally, the service agency chosen to perform warranty repairs must contact our Service Department at 423-775-2131 for authorization. Unauthorized repairs made will not be paid by Suburban.

### THREE YEAR LIMITED WARRANTY ON HEAT EXCHANGER

The furnace heat exchanger is further warranted to be free from defects in material and workmanship during the third through fifth year after the date of original purchase. A replacement heat exchanger will be provided under the same conditions as stated in the two year warranty EXCEPT no labor reimbursement will be provided.

### LIMITATION OF WARRANTIES

ALL IMPLIED WARRANTIES (INCLUDING IMPLIED WARRANTIES OF MERCHANTABILITY) ARE HEREBY LIMITED IN DURATION TO THE PERIOD FOR WHICH EACH LIMITED WARRANTY IS GIVEN. SOME STATES DO NOT ALLOW LIMITATIONS ON HOW LONG AN IMPLIED WARRANTY LASTS SO THE ABOVE LIMITATIONS MAY NOT APPLY TO YOU. THE EXPRESSED WARRANTIES MADE IN THIS WARRANTY ARE EXCLUSIVE AND MAY NOT BE ALTERED, ENLARGED, OR CHANGED BY ANY DISTRIBUTOR, DEALER OR OTHER PERSON WHOMSOEVER.

### SUBURBAN WILL NOT BE RESPONSIBLE FOR:

1. Normal maintenance as outlined in the installation, operating and service instructions owner's manual including cleaning of component parts; such as, orifices and burners.
2. Initial checkouts and subsequent checkouts which indicate the furnace is operating properly, or diagnosis without repair.
3. Damage or repairs required as a consequence of faulty or incorrect installation or application not in conformance with Suburban instructions.
4. Failure to start and/or operate due to loose or disconnected wires; water or dirt in controls, fuel lines and gas tanks; restriction or alteration of return air circulation; low voltage.
5. Routine adjustments that may be required to the thermostat, electrode and burner.
6. Costs incurred in gaining access to the furnace.
7. Parts or accessories not supplied by Suburban.
8. Freight charges incurred from parts replacements.
9. Damage or repairs needed as a consequence of any misapplication, abuse, unreasonable use, unauthorized alteration, improper service, improper operation or failure to provide reasonable and necessary maintenance.
10. Suburban products whose serial number has been altered, defaced or removed.
11. Suburban products installed or warranty claims originating outside the Continental U.S.A., Alaska, Hawaii and Canada.
12. Damage as a result of floods, winds, lightning, accidents, corrosive atmosphere or other conditions beyond the control of Suburban.
13. ANY SPECIAL, INDIRECT OR CONSEQUENTIAL PROPERTY, ECONOMIC OR COMMERCIAL DAMAGE OF ANY NATURE WHATSOEVER. Some states do not allow the exclusion of incidental or consequential damages, so the above limitation may not apply to you.

NO REPRESENTATIVE, DEALER OR OTHER PERSON IS AUTHORIZED TO ASSUME FOR SUBURBAN MANUFACTURING COMPANY ANY ADDITIONAL, DIFFERENT OR OTHER LIABILITY IN CONNECTION WITH THE SALE OF THIS SUBURBAN PRODUCT.

This warranty gives you specific legal rights, and you may also have other rights which vary from state to state.

### IF YOU HAVE A PRODUCT PROBLEM

#### FIRST:

If your RV has its original furnace and is still under the RV manufacturer's warranty, follow the steps described in your RV owner's manual.

#### SECOND:

Contact a conveniently located recommended Suburban Service Center. Describe to them the nature of your problem, make an appointment, if necessary, and provide for delivery of the furnace to the selected service center.

#### THIRD:

For the location of the nearest service center, refer to the listing provided or contact:

Suburban Manufacturing Company  
Customer Service Department  
Post Office Box 399  
Dayton, Tennessee 37321  
(423) 775-2131, Ext. 1

For future reference, you should record the following information
MODEL NUMBER _____
SERIAL NUMBER _____
STOCK NUMBER _____
DATE OF PURCHASE _____