

**600 Series PENGUIN  
579 Series BRISK AIR  
590 Series QUICK COOL  
595 Series QUICK COOL  
Roof Top Air Conditioner**

USED WITH

**Part No. 3104998 Relay Kit  
WITH REMOTE BI-METAL THERMOSTAT  
DUCTED**

**THIS UNIT IS DESIGNED FOR OEM INSTALLATION  
ALL INITIAL INSTALLATIONS MUST BE APPROVED BY THE SALES DEPT.**

**USA**  
SERVICE OFFICE  
Dometic Corporation  
2320 Industrial Parkway  
Elkhart, IN 46515  
574-294-2511

**CANADA**  
Dometic Distribution  
866 Langs Dr.  
Cambridge, Ontario  
CANADA N3H 2N7  
519-653-4390

**For Service Center  
Assistance Call:**  
800-544-4881

**⚠ WARNING**

**This manual must be read and understood before installation, adjustment, service, or maintenance is performed. This unit must be installed by a qualified service technician. Modification of this product can be extremely hazardous and could result in personal injury or property damage.**

**⚠ AVERTISSEMENT**

**Lire et comprendre ce manuel avant de procéder à l'installation, à des réglages, de l'entretien ou des réparations. L'installation de cet appareil doit être effectuée par un réparateur qualifié. Toute modification de cet appareil peut être extrêmement dangereuse et entraîner des blessures ou dommages matériels.**



**MODELS**

57908.321	57915.521	59016.626	59529.601
57908.331	57915.522	59516.331	59529.631
57908.521	57915.526	59516.501	59530.531
57912.321	57915.531	59516.506	59530.532
57912.531	57915.536	59516.531	59530.536
57912.621	57915.621	59516.336	59530.601
57912.622	57915.622	59516.536	59530.631
57912.631	57915.626	59516.601	59530.632
57915.331	57915.631	59516.603	600312.321
57915.336	57915.731	59516.606	600312.421
57915.421	59016.521	59516.631	600315.321
57915.422	59016.526	59528.601	600315.326
57915.426	59016.621	59529.531	600315.421

**INSTALLATION INSTRUCTIONS**

**REVISION**  
Form No. 3104994.144 3/05  
(Replaces 3104994.136)  
(French 3108174.058)  
©2005 Dometic Corporation  
LaGrange, IN 46761

**Important:  
Instructions must stay with unit.  
Owner read carefully.**

## SAFETY INSTRUCTIONS

This manual has safety information and instructions to help users eliminate or reduce the risk of accidents and injuries.

### RECOGNIZE SAFETY INFORMATION



This is the safety-alert symbol. When you see this symbol in this manual, be alert to the potential for personal injury.

Follow recommended precautions and safe operating instructions.

### UNDERSTAND SIGNAL WORDS

A signal word, **WARNING OR CAUTION** is used with the safety-alert symbol. They give the level of risk for potential injury.

**WARNING** indicates a potentially hazardous situation which, if not avoided, could result in death or serious injury.

**CAUTION** indicates a potentially hazardous situation which, if not avoided may result in minor or moderate injury.

**CAUTION** used without the safety alert symbol indicates, a potentially hazardous situation which, if not avoided may result in property damage.

Read and follow all safety information and instructions.

## 1. GENERAL INFORMATION

### A. This air conditioner is designed for:

1. Installation on a recreational vehicle at the time the vehicle is manufactured.
2. Mounting on the roof of a recreational vehicle.
3. Connection to an air distribution system located in the ceiling/roof cavity of the recreational vehicle.
4. Roof construction with rafters/joists on minimum of 16 inch centers.
5. Minimum of 2.00 inches and maximum of 5.50 inches distance between roof to ceiling of recreational vehicle. Alternate installation methods will allow for roofs more than 5.50 inches thick.

**B.** The ability of the air conditioner to maintain the desired inside temperature depends on the heat gain of the RV. Some preventative measures taken by the occupants of the RV can reduce the heat gain and improve the performance of the air conditioner/heat pump. During extremely high outdoor temperatures, the heat gain of the vehicle may be reduced by:

1. Parking the RV in a shaded area
2. Using window shades (blinds and/or curtains)
3. Keeping windows and doors shut or minimizing usage
4. Avoiding the use of heat producing appliances

Operation on High Fan/Cooling mode will give optimum or maximum efficiency in high humidity or high outside temperature.

Starting the air conditioner early in the morning and giving it a "head start" on the expected high outdoor ambient will greatly improve its ability to maintain the desired indoor temperature.

For a more permanent solution to a high heat gain, accessories like A&E outdoor patio and window awnings will reduce heat gain by removing the direct exposure to the sun. They also add a nice area to enjoy company during the cool of the evening.

### C. Condensation

**Note:** The manufacturer of this air conditioner will not be responsible for damage caused by condensed moisture on ceilings or other surfaces. Air contains moisture and this moisture tends to condense on cold surfaces. When air enters the RV, condensed moisture may appear on the ceiling, windows, metal parts, etc. The air conditioner removes this moisture from the air during normal operation. Keeping doors and windows closed when this air conditioner/heat pump is in operation will minimize condensed moisture on cold surfaces.

# SPECIFICATIONS

MODEL NO.	NOMINAL CAPACITY (BTU/HR) COOLING	ELECTRICAL RATING	COMPRESSOR RATED LOAD AMPS	COMPRESSOR LOCKED ROTOR AMPS	FAN MOTOR RATED LOAD AMPS	FAN MOTOR LOCKED ROTOR AMPS	SCFM-HIGH SPEED MAX/MIN	TOTAL STATIC MAX/MIN " W. C.	REFRIGERANT R-22 (OZ)	MINIMUM WIRE SIZE	AC PROTECTION *** USER SUPPLIED	INSTALLED WEIGHT (POUNDS)	MINIMUM GENERATOR SIZE** 1 UNIT/2 UNITS
57908.321	7,180	120VAC, 60 HZ., 1PH.	6.9	36.0	2.5	5.8	325 / 250	0.55 / 0.90	16.0	12 AWG Copper up to 24'	20 Amp	75	2.5 KW / 4.0 KW
57908.331	7,180		6.9	36.0	2.5	5.8	325 / 250	0.55 / 0.90	16.0		20 Amp	75	2.5 KW / 4.0 KW
57908.521	7,100		6.6	34.0	2.5	5.8	325 / 250	0.55 / 0.90	17.0		20 Amp	75	2.5 KW / 4.0 KW
57912.321	11,000		9.5	53.0	2.5	5.8	325 / 250	0.55 / 0.90	15.5		20 Amp	94	2.5 KW / 4.0 KW
57912.531	11,000		8.0	53.0	2.5	5.8	325 / 250	0.55 / 0.90	18.5		20 Amp	94	2.5 KW / 4.0 KW
57912.621	11,000	120VAC, 60 HZ., 1PH.	8.5	48.3	2.5	5.8	325 / 250	0.55 / 0.90	16.0	12 AWG Copper up to 24'	20 Amp	94	2.5 KW / 4.0 KW
57912.622	11,000		8.5	48.3	2.5	5.8	325 / 250	0.55 / 0.90	18.0		20 Amp	94	2.5 KW / 4.0 KW
57912.631	11,000		8.5	48.3	2.5	5.8	325 / 250	0.55 / 0.90	18.0		20 Amp	94	2.5 KW / 4.0 KW
57915.331	13,500		11.4	58.0	2.5	5.8	325 / 250	0.55 / 0.90	15.5		20 Amp	100	3.5 KW / 5.0 KW
57915.336	13,500		12.1	59.0	2.5	5.8	325 / 250	0.55 / 0.90	16.5		20 Amp	100	3.5 KW / 5.0 KW
57915.421	13,500		11.5	50.0	2.5	5.8	325 / 250	0.55 / 0.90	13.5		20 Amp	100	3.5 KW / 5.0 KW
57915.422	13,500		11.5	50.0	2.5	5.8	325 / 250	0.55 / 0.90	14.5		20 Amp	100	3.5 KW / 5.0 KW
57915.426	13,500		11.5	50.0	2.5	5.8	325 / 250	0.55 / 0.90	13.5		20 Amp	100	3.5 KW / 5.0 KW
57915.521	13,500		12.1	59.0	2.5	5.8	325 / 250	0.55 / 0.90	16.0		20 Amp	94	3.5 KW / 5.0 KW
57915.522	13,500		12.1	59.0	2.5	5.8	325 / 250	0.55 / 0.90	16.5		20 Amp	94	3.5 KW / 5.0 KW
57915.526	13,500	120VAC, 60 HZ., 1PH.	12.1	59.0	2.5	5.8	325 / 250	0.55 / 0.90	16.0	12 AWG Copper up to 24'	20 Amp	94	3.5 KW / 5.0 KW
57915.531	13,500		12.1	59.0	2.5	5.8	325 / 250	0.55 / 0.90	16.5		20 Amp	94	3.5 KW / 5.0 KW
57915.536	13,500		12.1	59.0	2.5	5.8	325 / 250	0.55 / 0.90	16.5		20 Amp	94	3.5 KW / 5.0 KW
57915.621	13,500		11.0	54.4	2.5	5.8	325 / 250	0.55 / 0.90	16.0		20 Amp	94	3.5 KW / 5.0 KW
57915.622	13,500		11.0	54.4	2.5	5.8	325 / 250	0.55 / 0.90	16.5		20 Amp	94	3.5 KW / 5.0 KW
57915.626	13,500		11.0	54.4	2.5	5.8	325 / 250	0.55 / 0.90	16.0		20 Amp	94	3.5 KW / 5.0 KW
57915.631	13,500		11.0	54.4	2.5	5.8	325 / 250	0.55 / 0.90	16.5		20 Amp	94	3.5 KW / 5.0 KW
57915.731	13,500		11.3	56.0	2.5	5.8	325 / 250	0.55 / 0.90	15.0		20 Amp	94	3.5 KW / 5.0 KW
59016.521	15,000		12.9	71.0	2.5	6.0	350 / 250	0.40 / 1.10	26.5		20 Amp	101	3.5 KW / 5.0 KW
59016.526	15,000		12.9	71.0	2.5	6.0	350 / 250	0.40 / 1.10	26.5		20 Amp	101	3.5 KW / 5.0 KW
59016.621	15,000	120VAC, 60 HZ., 1PH.	12.9	77.0	2.5	6.0	350 / 250	0.40 / 1.10	26.5	12 AWG Copper up to 24'	20 Amp	101	3.5 KW / 5.0 KW
59516.331	15,000		11.5	50.0	2.5	5.8	325 / 250	0.40 / 1.10	29.0		20 Amp	94	3.5 KW / 5.0 KW
59516.336	15,000		12.7	60.0	2.0	5.6	325 / 250	0.40 / 1.10	29.0		20 Amp	94	3.5 KW / 5.0 KW
59516.501	15,000		11.5	50.0	2.5	5.8	325 / 250	0.40 / 1.10	31.0		20 Amp	94	3.5 KW / 5.0 KW
59516.506	15,000		12.9	71.0	2.5	6.0	325 / 250	0.40 / 1.10	31.0		20 Amp	102	3.5 KW / 5.0 KW
59516.531	15,000		11.5	50.0	2.5	5.8	325 / 250	0.40 / 1.10	26.5		20 Amp	94	3.5 KW / 5.0 KW
59516.536	15,000		11.5	50.0	2.5	5.8	325 / 250	0.40 / 1.10	29.0		20 Amp	94	3.5 KW / 5.0 KW
59516.601	15,000		12.9	77.0	2.5	6.0	350 / 250	0.40 / 1.10	31.0		20 Amp	102	3.5 KW / 5.0 KW
59516.603	15,000		12.3	77.0	2.0	5.6	325 / 250	0.40 / 1.10	29.5		20 Amp	102	3.5 KW / 5.0 KW
59516.606	15,000		12.9	71.0	2.0	6.0	325 / 250	0.40 / 1.10	31.0		20 Amp	102	3.5 KW / 5.0 KW

\* For wire lengths over 24 ft. consult the National Electric Code for proper sizing.

\*\* Dometic Corporation gives **GENERAL** guidelines for generator requirements. These guidelines come from experiences people have had in actual applications. When sizing the generator, the total power usage of your recreational vehicle must be considered. Keep in mind generators lose power at high altitudes and from lack of maintenance.

\*\*\* **CIRCUIT PROTECTION:** Time Delay Fuse or HACR Circuit Breakers Required.

## SPECIFICATIONS

MODEL NO.	NOMINAL CAPACITY (BTU/HR) COOLING	ELECTRICAL RATING	COMPRESSOR RATED LOAD AMPS	COMPRESSOR LOCKED ROTOR AMPS	FAN MOTOR RATED LOAD AMPS	FAN MOTOR LOCKED ROTOR AMPS	SCFM-HIGH SPEED MAX/MIN	TOTAL STATIC MAX/MIN " W. C.	REFRIGERANT R-22 (OZ)	MINIMUM WIRE SIZE*	AC PROTECTION ***USER SUPPLIED	INSTALLED WEIGHT (POUNDS)	MINIMUM GENERATOR SIZE** 1 UNIT/2 UNITS
59516.631	15,000	120VAC, 60 HZ., 1PH.	12.3	77.0	2.0	5.6	325 / 250	0.40 / 1.10	29.5	12 AWG	20 Amp	102	3.5KW / 5.0KW
59528.601	N/A		6.0	45.6	2.0	5.6	325 / 250	0.41 / 1.10	16.5	Copper up to 24'	15 Amp	92	3.5 KW / 5.0 KW
59529.531	N/A		6.9	49.0	2.0	5.6	325 / 250	0.40 / 1.10	18.5		15 Amp	94	3.5 KW / 5.0 KW
59530.601	N/A		8.0	48.3	2.0	5.6	325 / 250	0.40 / 1.10	19.0		15 Amp	94	3.5 KW / 5.0 KW
59530.631	N/A		8.0	48.3	2.0	5.6	325 / 250	0.40 / 1.10	19.0		15 Amp	94	3.5 KW / 5.0 KW
59530.531	N/A		7.8	53.0	2.0	5.6	325 / 250	0.40 / 1.10	19.0		15 Amp	94	3.5 KW / 5.0 KW
59530.532	N/A		8.0	53.0	2.5	5.8	325 / 250	0.40 / 1.10	18.5		15 Amp	94	3.5 KW / 5.0 KW
59530.536	N/A		7.8	53.0	2.0	5.6	325 / 250	0.40 / 1.10	19.0		15 Amp	94	3.5 KW / 5.0 KW
59530.601	N/A		8.0	48.3	2.0	5.6	335 / 250	0.40 / 1.10	19.0		15 Amp	93	3.5 KW / 5.0 KW
59530.631	N/A		8.0	48.3	2.0	5.6	335 / 250	0.40 / 1.10	19.0		15 Amp	94	3.5 KW / 5.0 KW
59530.632	N/A		8.5	48.3	2.5	5.8	325 / 250	0.40 / 1.10	18.0		15 Amp	94	2.5 KW / 4.0 KW
600312.321	11,000		9.5	53.0	3.1	8.8	335 / 250	0.12 / 0.65	16.5		20 Amp	95	2.5 KW / 4.0 KW
600312.421	11,000		10.7	50.0	3.1	8.8	335 / 250	0.12 / 0.65	16.0		20 Amp	101	2.5 KW / 4.0 KW
600315.321	13,500		12.4	60.0	3.1	8.8	335 / 250	0.12 / 0.65	15.5		20 Amp	96	3.5 KW / 5.0 KW
600315.326	13,500		12.4	60.0	3.1	8.8	335 / 250	0.12 / 0.65	17.0		20 Amp	102	3.5 KW / 5.0 KW
600305.421	13,500		11.5	50.0	3.1	8.8	335 / 250	0.12 / 0.65	15.5		20 Amp	96	3.5 KW / 5.0 KW

\* For wire lengths over 24 ft. consult the National Electric Code for proper sizing.

\*\* Dometic Corporation gives **GENERAL** guidelines for generator requirements. These guidelines come from experiences people have had in actual applications. When sizing the generator, the total power usage of your recreational vehicle must be considered. Keep in mind generators lose power at high altitudes and from lack of maintenance.

\*\*\* **CIRCUIT PROTECTION:** Time Delay Fuse or HACR Circuit Breakers Required.

## 2. PRECAUTIONS

### **⚠ WARNING**

**Improper installation may damage equipment, could endanger life, cause serious injury and/or property damage.**

- A. Read Installation and Operating instructions carefully before attempting to start your air conditioner/heat pump installation.
- B. The Dometic Corporation will not be liable for any damages or injury incurred due to failure in following these instructions.
- C. Installation must comply with the National Electrical Code and any State or Local Codes or regulations.
- D. DO NOT add any devices or accessories to this air conditioner except those specifically authorized by Dometic.
- E. This equipment must be serviced by qualified personnel and some states require these people to be licensed.

## 3. CHOOSING LOCATION FOR THE AIR CONDITIONER

This air conditioner is specifically designed for installation on the roof of a recreational vehicle (RV).

### A. For One Unit Installation:

The air conditioner/heat pump should be mounted slightly forward of center (front to back) and centered from side to side.

### B. For Two Unit Installations:

Install one air conditioner/heat pump one-third and one air conditioner two-thirds from front of RV and centered from side to side.

It is preferred that the air conditioner/heat pump be installed on a relatively **flat and level** roof section measured with the RV parked on a level surface; however,

1. Up to an 8° slant to either side or front-to-back is acceptable on 600 Series Air Conditioners.
2. Up to a 15° slant to either side or front-to-back is acceptable on 579, 590, 591 or 595 Series Air conditioners.

### AFTER LOCATION HAS BEEN SELECTED:

- a. Check for obstructions in the area where air conditioner/heat pump will be installed. See FIG. 1.
- b. The roof must be designed to support 130 pounds when the RV is in motion. Normally 200 pound static load design will meet this requirement.

### **⚠ CAUTION**

**It is the responsibility of the installer of this air conditioner system to ensure structural integrity of the RV roof. Never create a low spot on the roof where water will collect. Water standing around the air conditioner may leak into the interior causing damage to the product and the RV.**

**FIG. 1 AIR CONDITIONER DIMENSIONS (On Top of Vehicle)  
579, 590, 591 & 595 SERIES**

KEEP THIS AREA FREE OF OBSTRUCTIONS

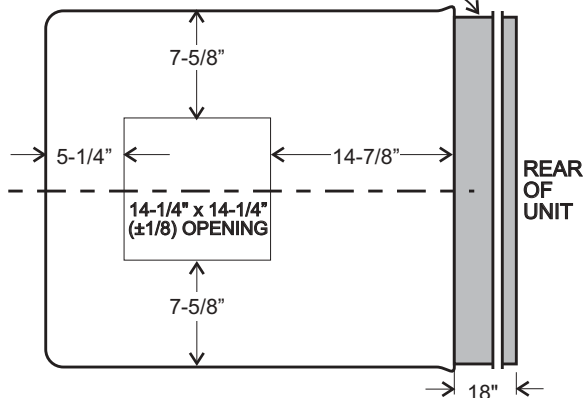

**600 SERIES**

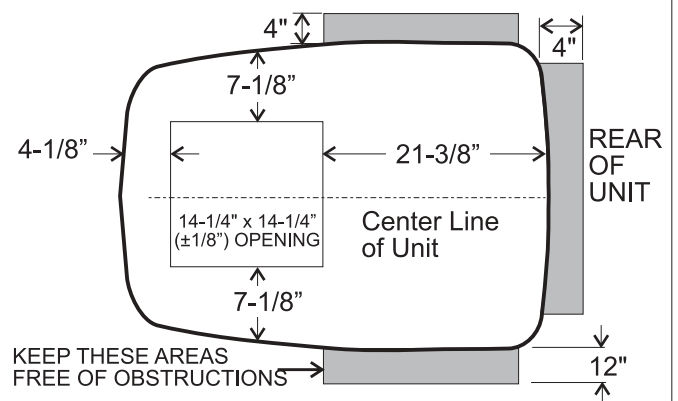

## 4. AIR DISTRIBUTION SYSTEM SIZING & DESIGN

The Installer of this air conditioner system must design the air distribution system for their particular application. Several requirements for this system **MUST** be met for the air conditioner to operate properly. These requirements are as follows:

- A. The duct material must meet or exceed any agency or RVIA Standard that may be in existence at the time the RV is produced.
- B. All discharge air ducts must be properly insulated to prevent condensation from forming on their surfaces or adjacent surfaces during operation of the air conditioner. This insulation must be R-7 minimum.
- C. Ducts and their joints must be sealed to prevent condensation from forming on adjacent surfaces during operation of the air conditioner.
- D. Return air openings must have 40 square inches minimum free area including the filter.
- E. Return air to the air conditioner must be filtered to prevent dirt accumulation on air conditioner cooling surface.

### CAUTION

**It is the responsibility of the installer of insure the ductwork will not collapse or bend during and after the installation. Dometic Corporation will not be liable for roof structural or ceiling damage due to improperly insulated, sealed or collapsed ductwork.**

### AIR DISTRIBUTION DUCT SIZING & DESIGN CHART

<b>Return Air Cover Model</b>	3105007.XXX 3105935.XXX	**3308120.XXX Genesis Air Filtration System
<b>Roof Cavity Depth</b>	2.0 In. Min. - 5-1/2 In. Max.	2.0 In. Min. - 5-1/2 In. Max.
<b>Duct Cross Sectional Area</b>	21.0 Sq. In. Min.	32.0 Sq. In. Min.
<b>Duct Size</b> Depth Width Total Duct Length Duct Length (short run)	1-1/2 In. Min. - 2-1/2 In. Max. 7.0 In. Min. - 10.0 In. Max. 15.0 Ft. Min. - 40.0 Ft. Max. 1/3 Total Duct Length	2.0 In. Min. - 2-1/2 In. Max. 8.0 In. Min. - 10.0 In. Max. 15.0 Ft. Min. - 40.0 Ft. Max. 1/3 Total Duct Length
<b>Register Requirements</b> Number Required Per Run Register Free Air Area Distance From Duct End Distance From Elbow	4 Min. 14.0 Sq. In. 5.0 In. Min. - 8.0 In. Max. 15.0 In.	4 Min. 14.0 Sq. In. 5.0 In. Min. - 8.0 In. Max. 15.0 In.
<b>Duct Static</b> Blower at High Speed, Filter & Grill In Place	0.55 - 0.90 In. W.C. 579 Series 0.40 - 1.10 In. W.C. 590, 591, 595 Series 600 Series 0.12 - 0.65 In. W.C.	0.55 - 0.90 In. W.C. 579 Series 0.40 - 1.10 In. W.C. 590, 591, 595 Series 600 Series 0.12 - 0.65 In. W.C.

**Note:** Duct sizes listed are inside dimensions.

\*\* 12VDC Power supply is required.

## 5. AIR DISTRIBUTION SYSTEM INSTALLATION

- A. Dometic Corporation recommends the basic configuration shown on page 8, for installing this air conditioner system. We have found by testing, that this configuration works best in most applications of this air conditioner. It is the responsibility of the Installer of this system to review each RV floor plan and determine the following:
1. Duct size
  2. Duct layout
  3. Register size
  4. Register location
  5. Thermostat location

These items must be determined in conjunction with the Air Distribution System and Sizing and Design Requirements listed in the chart on page 6.

**Important:** Alternate configurations and methods may be used which still allow the air conditioner to operate properly; however, these alternate configurations and methods must be approved by the Dometic Corporation in writing. The following instructions are based upon the use of Dometic 3105007.XXX Return Air Kits, 3105935.XXX Quick Cool Kits, or 3308120.XXX Genesis Air Filtration System (3308120.XXX Genesis Air Filtration System indicator light requires 12VDC power from the vehicle). The 3104998.XXX control kit has the mounting bolts supplied for use with these kits.

### B. ROOF AND CEILING OPENING PREPARATION

#### **WARNING**

**There may be electrical wiring between the roof and the ceiling. Disconnect 120 volt AC power cord and the positive (+) 12 volt DC terminal at the supply battery. Failure to follow this instruction may create a shock hazard causing death or severe personal injury.**

1. A 14-1/4" x 14-1/4" ( $\pm 1/8$ ") opening must be cut through the roof and ceiling of the RV. This opening must be located between the roof reinforcing members.
2. Mark a 14-1/4" x 14-1/4" ( $\pm 1/8$ ") square on the roof and carefully cut the opening.
3. Using the roof opening as a guide, cut the matching hole in the ceiling.
4. The opening created must be framed to provide adequate support and prevent air from being drawn from the roof cavity. Lumber 3/4" or more in thickness must be used. Remember to provide an entrance hole for power supply wiring and thermostat cable.
5. The 14-1/4" x 14-1/4" ( $\pm 1/8$ ") opening is part of the return air system of the air conditioner and must be finished in accordance with NFPA Standard 501C Section 2.7.
6. Route a copper 12 AWG, with ground, 120VAC supply line from the fuse or circuit breaker box to the roof opening.
  - a. This supply line must be located in the front portion of the 14-1/4" x 14-1/4" ( $\pm 1/8$ ") opening.
  - b. The power supply **MUST** be on a separate Time Delay Fuse or HACR Circuit Breaker (20 amp for 579, 590, 591, 59516 and 600 series and 15 amp for 59528, 59529 and 59530).
  - c. Make sure at least 15" of supply wire extends into the roof opening. This ensures easy connection at the junction box.

**Note:** if using the 3308120.XXX return air cover. Route a 18 - 22 AWG. fused 12VDC power supply lead from the converter or battery to the roof opening. Make sure 15" of wire extends into the opening.
  - d. Wiring must comply with all National, State and Local Wiring Codes.
  - e. Use a steel sleeve and a grommet or equivalent methods to protect the wire where it passes into the opening.
7. See Section 6. Thermostat & Cable Installation

**C. AIR DISTRIBUTION DUCT INSTALLATION**

1. Install the Air Distribution Ducts in the RV Roof Cavity. The Distribution System must meet:
  - a. RV's requirements
  - b. System requirements listed in Section 4 on page 6 of this Manual. Terminate the start of the Duct at the back edge of the 14-1/4" x 14-1/4" (±1/8") opening previously cut. See FIG. 2, 3, & 4.

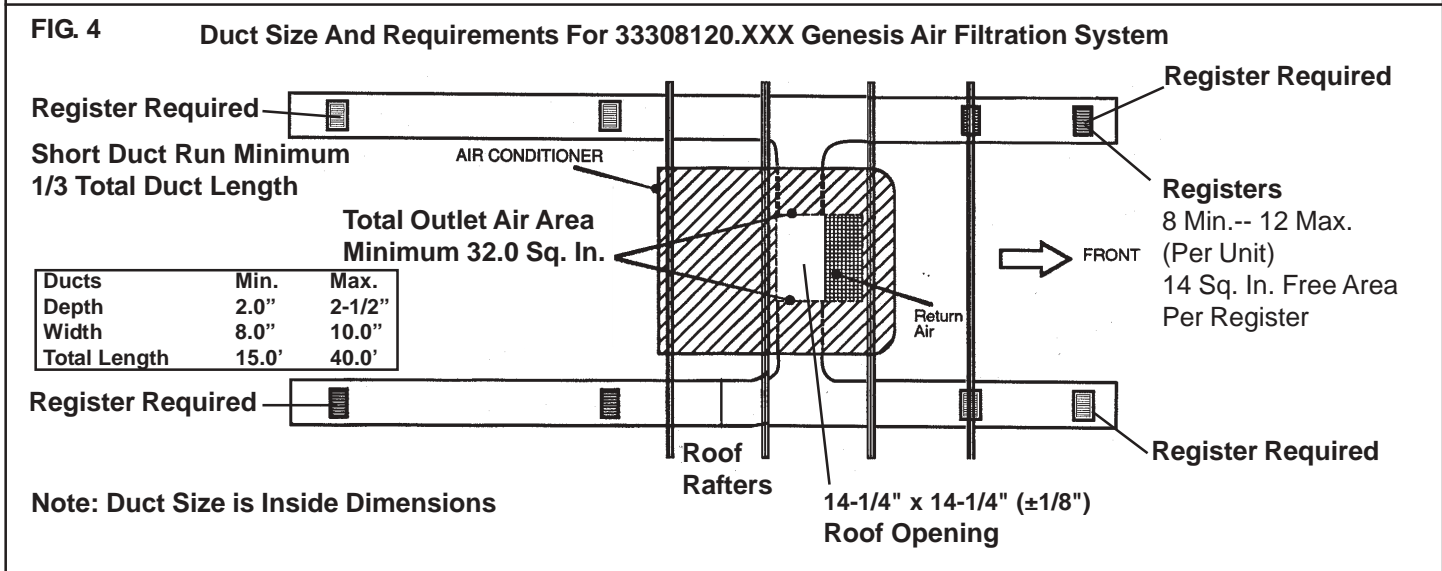
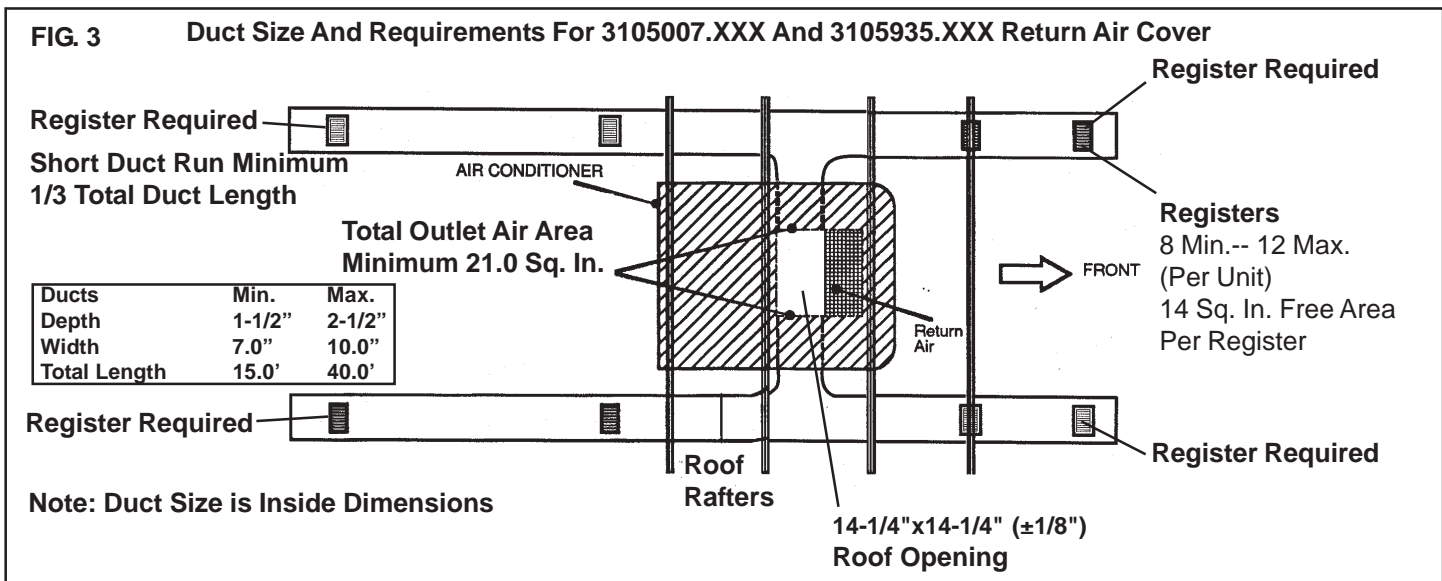
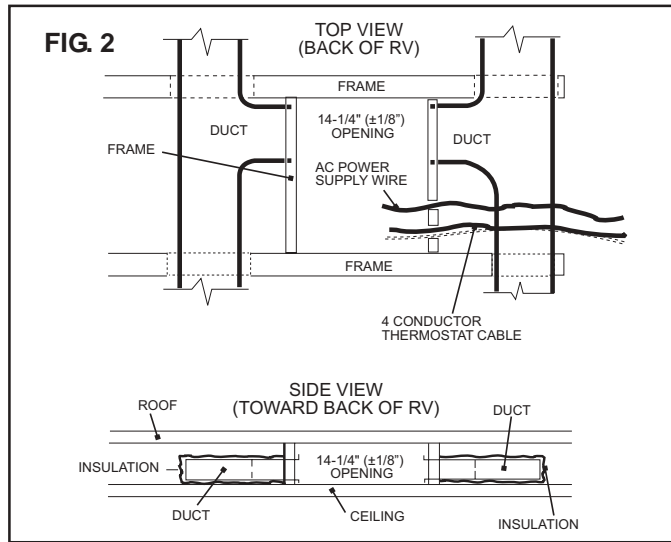



## 6. THERMOSTAT & CABLE INSTALLATION

### A. LOCATION

The proper location of the thermostat is very important to ensure that it will provide a comfortable RV temperature. Observe the following general rules when selecting a location.

1. Locate the thermostat 54" above the floor.
2. Install thermostat on a partition, **NEVER** on an outside wall.
3. **NEVER** expose it to direct heat from lamps, sun or other heat producing items.
4. Avoid locations close to doors that lead outside, windows or adjoining outside walls or directly under cabinets or overhangs which limit air movement.
5. Avoid locations close to supply registers and the air from them.
6. **NEVER** locate thermostat in a room that is warmer or cooler than the rest of the coach - such as the kitchen.
7. The major living area is normally a good location.

### B. CABLE INSTALLATION

1. A four-conductor cable, 18 to 22 AWG is to be used for low voltage connections.
2. Choose the shortest, direct route from the 14-1/4" x 14-1/4" ( $\pm 1/8$ ") opening to the thermostat location selected.
3. Consider where screws, nails or staples might contact the cable.
4. Leave approximately 6" of cable extending through the wall for connection to the thermostat.
5. Leave approximately 15" of cable extending into the 14-1/4" x 14-1/4" ( $\pm 1/8$ ") opening for connection at unit.
6. If system is to control a gas furnace: Route two 18 gauge wires from the furnace to wall thermostat.

## 7. PLACING THE AIR CONDITIONER ON THE ROOF

- A. Remove the air conditioner from the carton and discard carton. The unit mounting bolts and literature are in separate plastic bag. Be sure to place this information in the RV.
- B. Place the air conditioner on the roof.

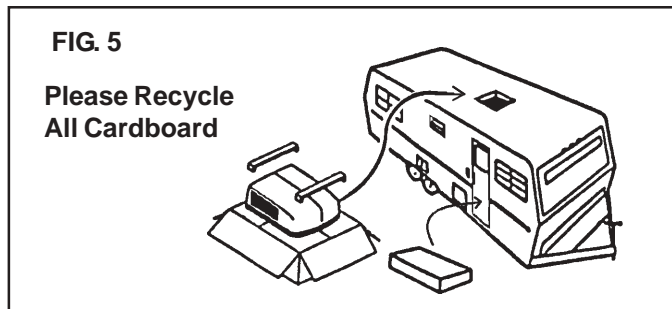

### CAUTION

This unit weighs approximately 100 pounds. To prevent back injury, use a mechanical hoist to place air Conditioner/heat pump on roof.

- C. Lift and place the unit over the prepared opening using the gasket on unit as a guide. The roof gasket on the bottom of the base pan goes toward the front of the RV. Sliding the unit on the roof will damage the roof gasket. See FIG. 6.

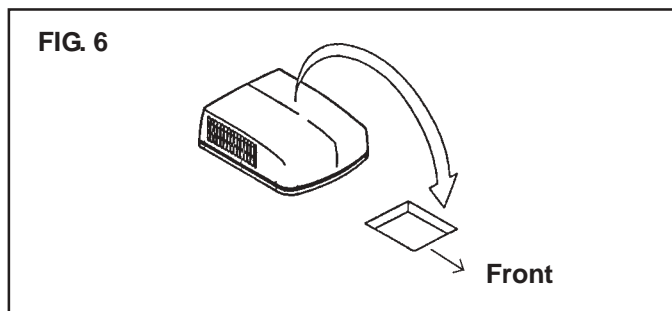

### CAUTION

Do not slide the unit. This may damage the neoprene gasket attached to the bottom and create a leaky installation.

- D. Place 3104998 Relay Kit and Return Air Cover Kit, inside the RV. These cartons contain mounting hardware for the air conditioner and will be used inside the RV. This completes the outside work. Minor adjustments can be done from the inside of the RV if required.

## 8. INSTALLATION OF COLD CONTROL

- A.** Remove parts package, control box and thermostat from the 3104998 Control Kit carton and identify the mounting for cold control. See FIGS. 7, 8 or FIGS. 8A, 8B.
- B.** Freeze Control Installation 579, 590, 591, & 595 Series Brisk Air Models (See FIG. 7.)
1. Snap freeze control into place on return bend located at left side of evaporator coil as follows:
    - a. Locate "D" shaped notch in flange of evaporator coil.
    - b. Place the horseshoe end of the freeze control through this notch and snap onto the coil return bend. When positioned correctly, control wires will be 90° to direction of coil fin surface.
    - c. Remove installation notice hang tag from freeze control.

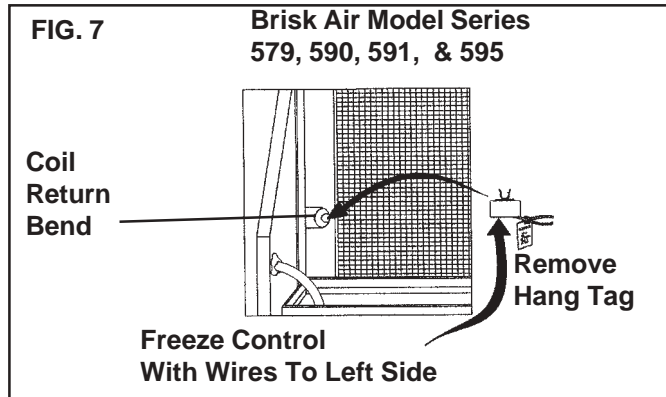

- C.** Freeze Control installation on 600 Series Penguin Models (See FIG. 8.)
1. Snap freeze control into place on return bend located at right side of evaporator coil as follows:
    - a. Locate "D" shaped notch in flange of evaporator coil.
    - b. Place the horseshoe end of the freeze control through this notch and snap onto the coil return bend. When positioned correctly, control wires will be 90° to direction of coil fin surface.
    - c. Remove installation notice hang tag from freeze control.

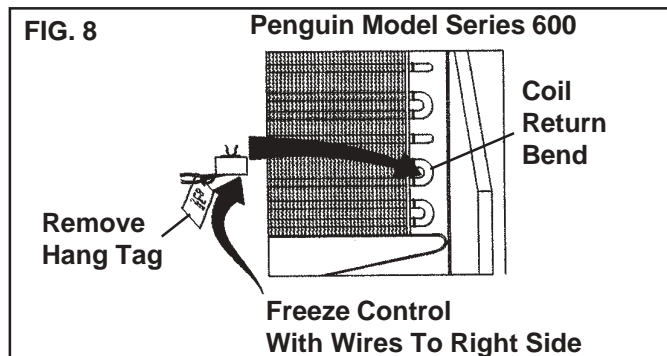

- D.** Freeze Control Installation with snap on spring clip
1. Fits on all 579, 590, 591, 595 and 600 Series Brisk Air and Penguin Models
    - a. Place the cold control switch up through the base pan and on the second refrigerant tube from the bottom in the center of the evaporator coil. Make sure the spring clip is fastened securely to the tubing and the cold control surface is making contact with aluminum fins on evaporator coil. See FIGS. 8A & 8B.
      - Keep wires away from heat strip (if applicable) and sharp edges to prevent damaging the wires. Use wire ties if necessary. See FIGS. 8A & 8B.
      - Remove installation notice hang tag from freeze control. See FIGS. 8A & 8B.

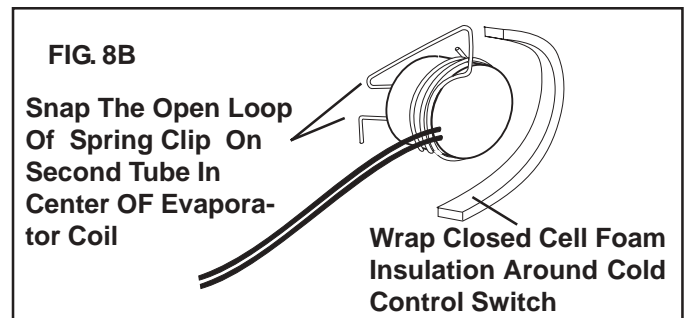
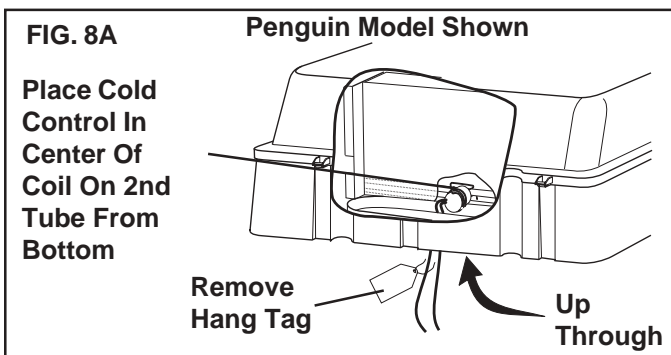

## 9. WIRING OF CONTROL SYSTEM

- A. Position the control box (standing up) with the 6 pin connector to the curb side of the vehicle and the service access facing the rear of the vehicle.
- B. CONNECTION OF 120 VOLT AC SUPPLY

### **⚠ WARNING**

Disconnect 120 volt AC. Failure to follow these instructions could create a shock hazard causing death or severe personal injury.

### **⚠ WARNING**

This product is equipped with a 3-wire (grounded) system for protection against shock hazard. Make sure that the appliance is wired into a properly grounded 120 volt AC circuit and the polarity is correct. Failure to do so could result in death, personal injury or damage to the equipment.

1. Route the previously run AC power supply line through the Romex Connector and into relay control junction box.
2. Reach up into the return air opening of the air conditioner and pull the unit electrical cord down for later installation.
3. Connect the white to white; black to black; and green to green or bare copper wire using appropriate sized twist wire connectors. Tape the twist wire connectors to the supply wiring to assure they do not vibrate off.
4. Tighten screws on Romex connector being careful not to pinch and cut into the insulation on power supply leads.
5. Push excess wires into junction box. Install junction box cover, with model number/serial number facing out onto the relay control box with #8 x 3/8" blunt point Phillips head screw provided.

**Note:** Model Number /Serial Number label must face out.

### C CONNECT LOW VOLTAGE WIRES

**Note:** If 3308120.XXX return air cover is being installed. Position the 12VDC supply wires out of the way to be connected after the decorative cover is installed.

1. Connect red wire from control box to the thermostat "RC" terminal.
2. Connect the control box orange wire to the thermostat "G" terminal.
3. Connect the control box yellow wire to the thermostat "Y" Terminal.
4. Connect the control box blue wire to the thermostat "H" terminal.

**Note:** The provided thermostat is a "heat/cool thermostat". These instructions cover only the cooling connections required. If connection of furnace is required, follow the instructions provided with the furnace. Normally the furnace will connect to the "RH" and "W" terminals on the thermostat.

**Note:** See FIG. 9 for thermostat connection points.

FIG. 9

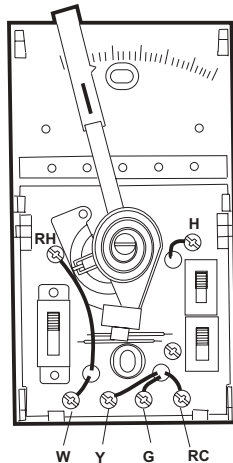

#### Thermostat Connections

Red Wire (Control Box) - "RC" (Thermostat)  
Orange Wire (Control Box) - "G" (Thermostat)  
Yellow Wire (Control Box) - "Y" (Thermostat)  
Blue Wire (Control Box) - "H" (Thermostat)  
Red (Furnace if Present) - "RH" (Thermostat)  
White (Furnace if Present) - "W" (Thermostat)

- D. Plug unit electrical cord into the mating connector on the relay control box. These connectors are polarized and will easily snap together. Do not force.

## 10. INSTALLATION OF AIR CONDITIONER

Installing unit with 3105007.XXX or 3105935.XXX  
Return Air Cover.

### A. INSTALLATION OF CEILING TEMPLATE

1. Check gasket alignment of the air conditioner over the roof opening and adjust if necessary. Unit may be moved from below by slightly lifting and sliding. See FIG. 11A.
2. Remove return air cover and ceiling template from the 3105007.XXX or 3105935.XXX kit carton.

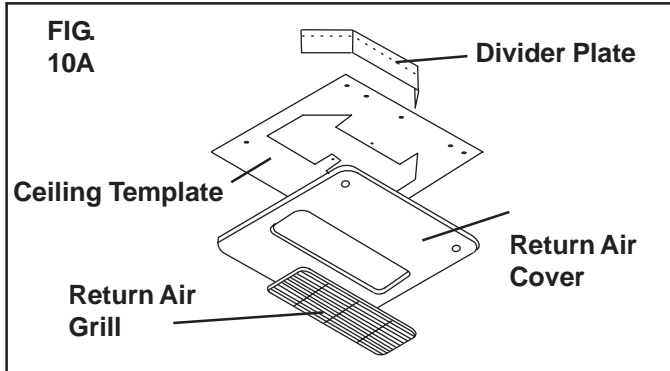

3. Locate 1/4" unit mounting bolts in the parts package.
4. Hold the ceiling template up to the 14-1/4" x 14-1/4" ( $\pm 1/8$ ") opening. Be sure the large plate faces the rear of the RV.

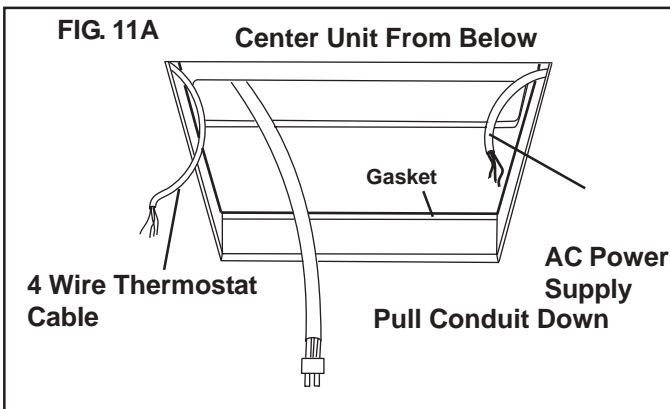

Installing unit with 3105007.XXX or 3105935.XXX  
Return Air Cover, continued on page 12, column A.

Installing unit with 3308120.XXX Genesis Air Filtration System.

**Note:** A 12VDC power source is required for this installation. See Section 5. B. Paragraph 6

### A. INSTALLATION OF FOAM DIVIDER

1. Locate the foam divider and insert it corner to corner in the 14-1/4" x 14-1/4" ( $\pm 1/8$ ") opening with the adhesive tape up (Do not remove paper to expose adhesive). The foam divider should be level with the ceiling ( $\pm 1/4$ "). Tear off the excess at the

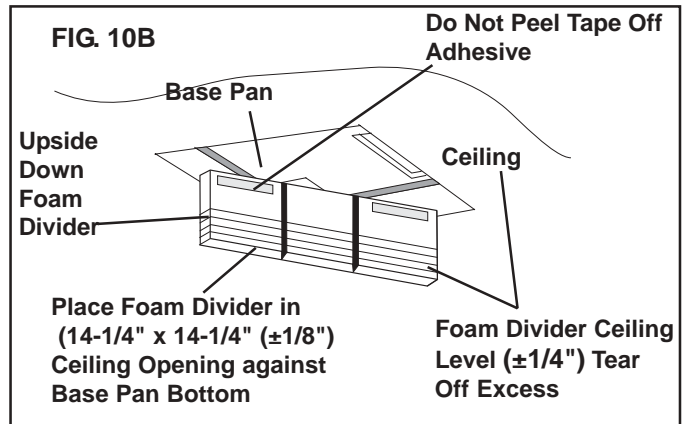

pre-cut perforations in divider. See FIG. 10B.

2. Peel the paper off of the foam divider and stick it in place on the center of the rear edge of the return air opening on the ceiling template See FIG. 11B.

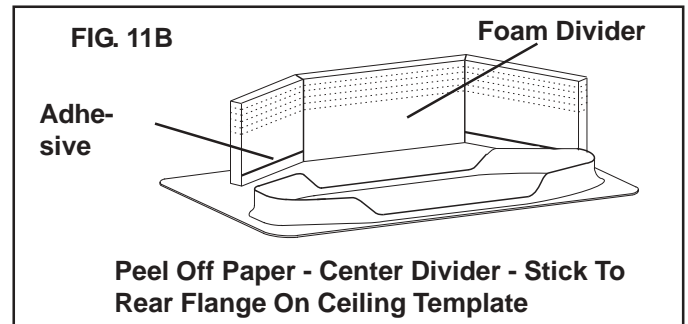

### B. INSTALL CEILING TEMPLATE

1. Position the electrical control box towards the front of the opening with all of the system control wires connected to the control box. Place the ceiling template up to the return air opening in the ceiling. See FIG. 12B.

Installing unit with 3308120.XXX Genesis Air Filtration

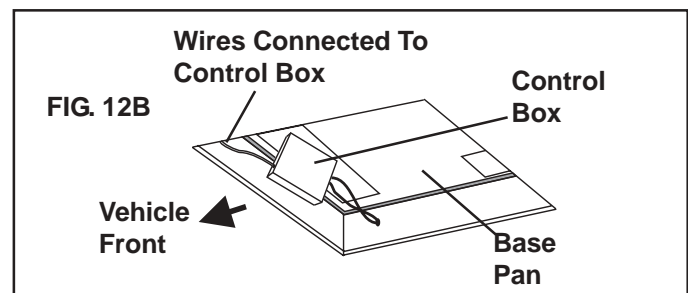

System, continued on page 13, column B.

Installing unit with 3308120.XXX Genesis Air Filtration

Installing unit with 3105007.XXX or 3105935.XXX  
Return Air Cover, continued from page 12, column A.

5. Start each mounting bolt through the ceiling template and up into the unit base pan by hand. **Evenly tighten mounting bolts to compress gasket to 1/2" this will be a torque of 40 - 50 inch pounds.** See FIG. 12A.

**CAUTION**

If bolts are left loose there may not be adequate roof seal or if over tightened, damage may occur to the air conditioner base or ceiling template. Tighten to specifications listed in this manual.

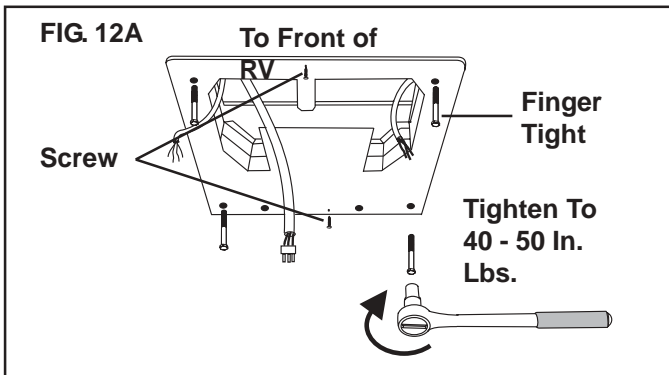

6. Install wood screw in each end of the ceiling template. This insures a tight fit of the return air cover to ceiling. See FIG. 12A

**B. INSTALLATION OF DIVIDER PLATE**

1. Measure the ceiling to roof thickness:
  - a. If distance is 2.0" - 3-3/4", remove perforated tab from divider plate.
  - b. If distance is 3-3/4" - 5-1/2", remove no tabs.
2. Remove the backing paper from double sided tape located on ceiling template. See FIG. 13A.

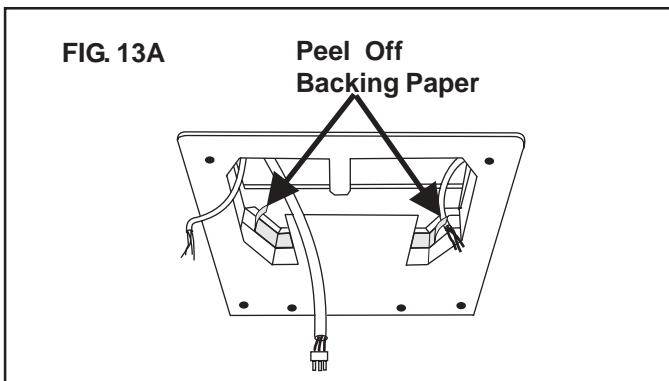

Installing unit with 3105007.XXX or 3105935.XXX  
Return Air Cover, continued on page 14, column A.

System, continued from page 12, column B.

2. Install relay box on ceiling template depending on the model use FIG. 13B for Brisk Air unit and Fig. 14B for Penguin units.

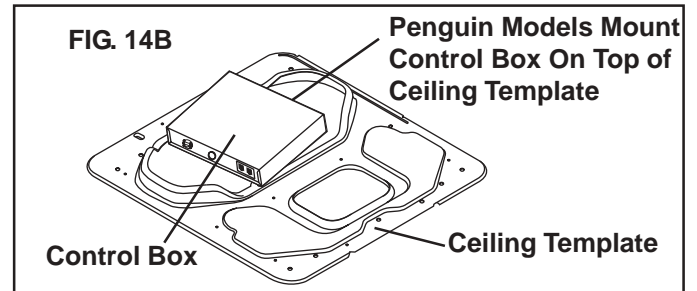
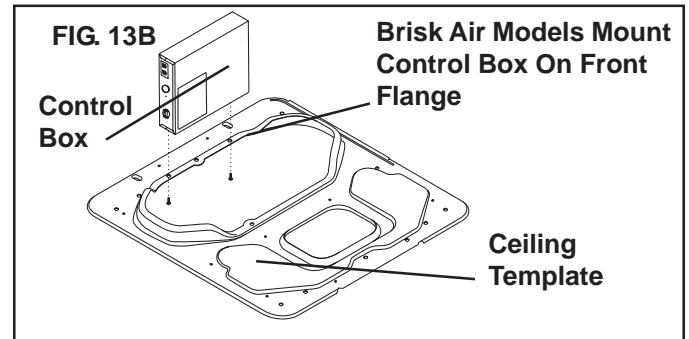

3. Start each mounting bolt through the ceiling template and up into the unit base pan by hand. **Evenly tighten mounting bolts to compress gasket to 1/2" this will be a torque of 40 - 50 inch pounds.**

**CAUTION**

If bolts are left loose there may not be adequate roof seal or if over tightened, damage may occur to the air conditioner base or ceiling template. Tighten to specifications listed in this manual.

4. Use Aluminum foil tape (not supplied) to seal the ends of the foam divider to the sides of the opening. Make sure the area behind the flange on the ceiling template is sealed. See FIG. 15B.

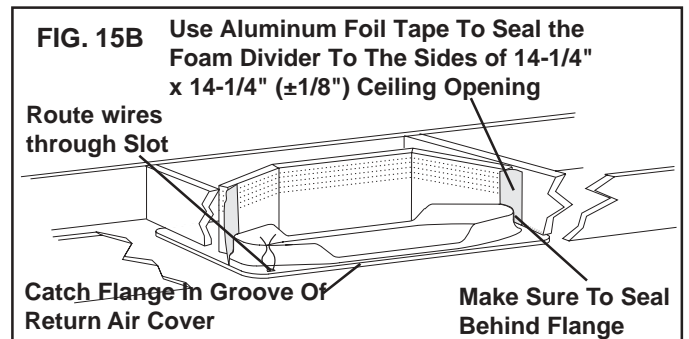

**Installing unit with 3105007.XXX or 3105935.XXX**  
**Return Air Cover, continued from page 13, column A.**

3. Place divider plate up to bottom of air conditioner base pan firmly. The foam tape on the divider plate must seal to bottom of base pan. See FIG. 14A.  
**Note:** The adhesive on the insulation is extremely sticky. Be sure the part is located where desired before pressing into place.

**CAUTION**

**Improper installation and sealing of divider plate will cause the compressor to quick cycle on the cold control. This may result in fuse or circuit breaker opening and/or lack of cooling.**

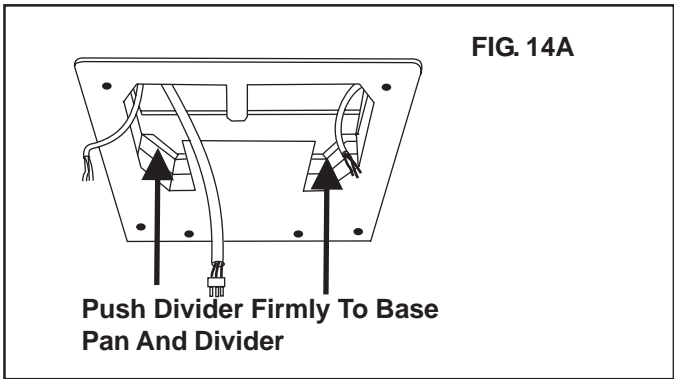

4. With slight pressure then push the divider plate against the double sided tape on the ceiling template.
5. Locate the 1/8" x 7" x 18" self-adhesive insulation supplied with the return air kit. Remove the backing paper from the insulation and carefully stick onto the ceiling template divider panel. See FIG. 15A.
  - a. Excess width is intended to seal the divider plate to the sides of the 14-1/4" x 14-1/4" ( $\pm 1/8$ ") opening. This is to help prevent cold air discharge from circulating into the air conditioner return air opening.
  - b. If the insulation is too high, stick excess height of insulation to the air conditioner base pan. Do not cover up unit rating plate.

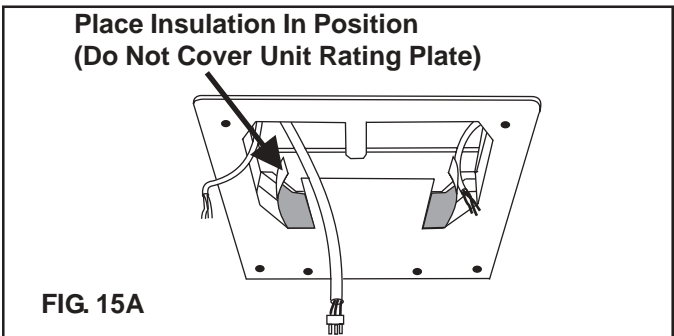

## 11. INSTALLATION OF INSIDE DECORATIVE COVER.

### Installing unit with 3105007.XXX or 3105935.XXX Return Air Cover.

- A. Locate the relay control box on the ceiling template with the white 6 connector plug on the right (curb side) side of RV.
- B. Drive two #10 x 3/8" blunt point Phillips head screws through the ceiling template into holes in control box to hold it in place.
- C. Remove the return air grill from the return air cover.
- D. Place the return air cover up to the ceiling template.
- E. Install cover to template with #8 x 3/8" blunt point Phillips head screws provided (6 required).
- F. Reinstall filter return air grill into return air cover. Align tabs with mating notches and snap into place
- G. Install two hole plugs into screw holes in back of return air cover. See FIG. 16A.

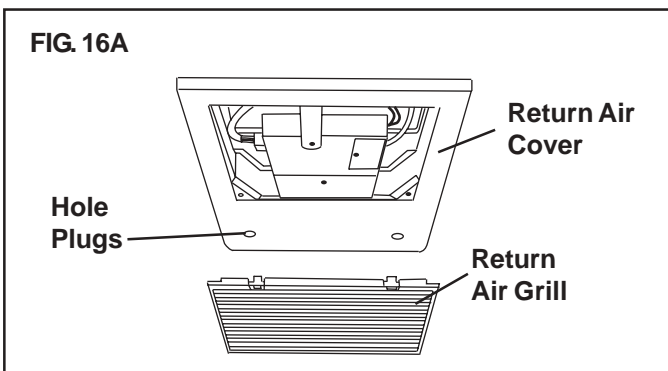

This completes the installation of the air conditioner. We recommend that power be supplied to the air conditioner/heat pump and check for proper operation. Refer to Operating Manual or Users Guide for a description of the air conditioner/heat pump operation.

### Installing unit with 3308120.XXX Genesis Air Filtration System.

- A. Install the slider in the return air cover and raise it to the ceiling template. Route the wires from the return air cover through the template slot leaving about 3" between, and position wire here they can be reach after plastic cover is installed. See FIG. 14B. Place the front of the return air cover against the ceiling and slide towards the rear. The flange on the ceiling template will catch in the groove on the return cover. Adjust the position (right to left) and install the front two screws. Install the remaining screws.
 

**Note:** Number 10 cabinet screw can be used to replace the two front screws to hold the plastic cover flush to the ceiling.

  1. Connect together the wires from the 12VDC power supply and filter indicator.
    - a. Connect the red wire from the (+12VDC) power supply and the red wire from the filter indicator light with the red. See figure 15B.
    - b. Connect the black (-12VDC) power supply and the black wire from the filter indicator light.

**Note:** If solar panel is installed see instructions packaged with solar panel option.
- B. Insert the filter from the right side (looking toward the RV front) over the wires. Make sure the wires are secured above the filter and will stay out of its way.
- C. Place grill on return air cover and snap in place. Decal is on end over circuit board.

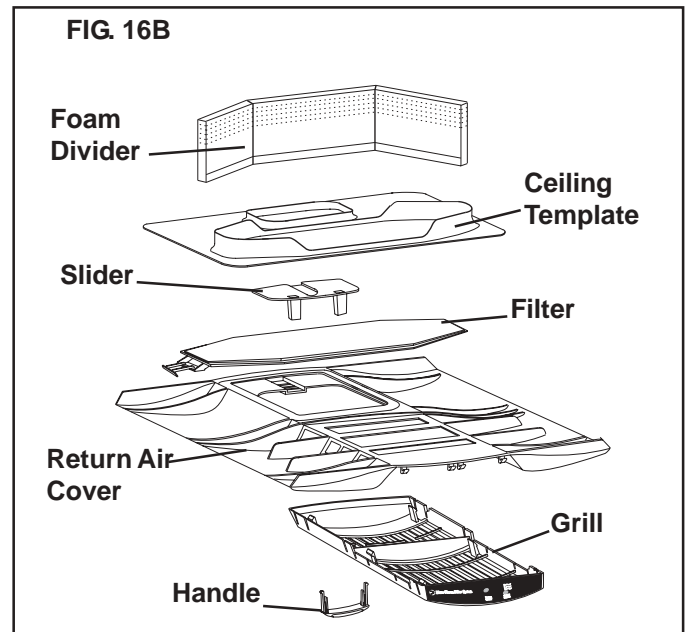

- D. Place slide handle through slots in grill into the slide posts. Handle will fit in either direction. This completes the installation of the air conditioner/heat pump. We recommend that power be supplied to the air conditioner/heat pump and check for proper operation. Refer to Operating Manual or Users Guide for a description of the air conditioner operation.

# RELAY KIT FIELD WIRING DIAGRAM

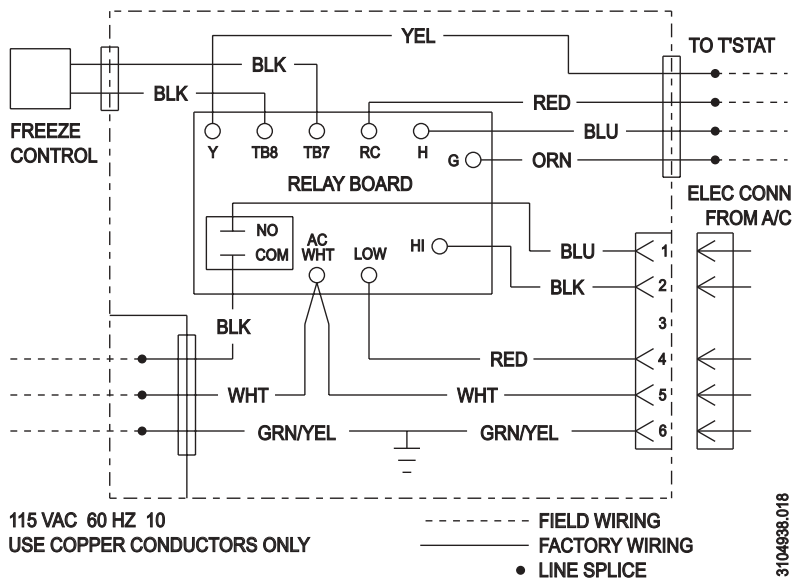

# UNIT FIELD WIRING DIAGRAM

