

RECORD THIS UNIT INFORMATION FOR  
FUTURE REFERENCE:  
Model Number \_\_\_\_\_  
Serial Number \_\_\_\_\_  
Date Purchased \_\_\_\_\_

# MODELS

## 620615, 620625, 620626 Series

Roof Top Air Conditioner  
Used With

3105007 Return Air Kit  
3105935 Quick Cool Return Air Kit  
3308120 Genesis Air Filtration System Return Air Kit  
Duo-Therm Remote Comfort Control

**This Unit Is Designed For OEM Installation. All Initial Installations Must Be Approved By Dometic Corporation**

**USA**  
SERVICE OFFICE  
Dometic Corporation  
509 South Poplar Street  
LaGrange, IN 46761  
260-463-4858

**CANADA**  
Dometic Distribution  
866 Langs Drive  
Cambridge, Ontario  
CANADA N3H 2N7  
(519) 653-4390

**For Service Center Assistance Call:**  
800-544-4881



### **WARNING**

This manual must be read and understood before installation, adjustment, service, or maintenance is performed. This unit must be installed by a qualified service technician. Modification of this product can be extremely hazardous and could result in personal injury or property damage.

### **AVERTISSEMENT**

Lire et comprendre ce manuel avant de procéder à l'installation, à des réglages, de l'entretien ou des réparations. L'installation de cet appareil doit être effectuée par un réparateur qualifié. Toute modification de cet appareil peut être extrêmement dangereuse et entraîner des blessures ou dommages matériels.

# INSTALLATION & OPERATING INSTRUCTIONS

## MODELS

620615.321 620625.326  
620615.326 620626.321  
620625.321 620626.326

**REVISION**  
Form No. 3308472.012 1/04  
(Replaces 3308472.004)  
(French 3308473.010)  
©2004 Dometic Corporation  
LaGrange, IN 46761

**Important: These Instructions must stay with unit. Owner read carefully.**

## SAFETY INSTRUCTIONS

This manual has safety information and instructions to help users eliminate or reduce the risk of accidents and injuries.

### RECOGNIZE SAFETY INFORMATION



This is the safety-alert symbol. When you see this symbol in this manual, be alert to the potential for personal injury.

Follow recommended precautions and safe operating instructions.

### UNDERSTAND SIGNAL WORDS

A signal word, **WARNING OR CAUTION** is used with the safety-alert symbol. They give the level of risk for potential injury.

**WARNING** indicates a potentially hazardous situation which, if not avoided, could result in death or serious injury.

**CAUTION** indicates a potentially hazardous situation which, if not avoided may result in minor or moderate injury.

**CAUTION** used without the safety alert symbol indicates, a potentially hazardous situation which, if not avoided may result in property damage.

Read and follow all safety information and instructions.

## GENERAL INFORMATION

- A. Product features or specifications as described or illustrated are subject to change without notice.
- B. **This air conditioner is designed for:**
  1. Installation on a recreational vehicle during the time the vehicle is manufactured.
  2. Mounting on the roof of a recreational vehicle.
  3. Connection to an air distribution system located in the ceiling/roof cavity of the recreational vehicle.
  4. Roof construction with rafters/joists on minimum of 16 inch centers.
  5. Minimum of 2.00" and maximum of 5.50" distance between roof to ceiling of recreational vehicle. Alternate installation methods will allow for roofs more than 5.50" thick.
- C. The ability of the air conditioner to maintain the desired inside temperature depends on the heat gain of the RV. Some preventative measures taken by the occupants of the RV can reduce the heat gain and improve the performance of the air conditioner. During extremely high outdoor temperatures, the heat gain of the vehicle may be reduced by:
  1. Parking the RV in a shaded area
  2. Using window shades (blinds and/or curtains)
  3. Keeping windows and doors shut or minimizing usage
  4. Avoiding the use of heat producing appliances.

Operation on High Fan/Cooling mode will give optimum or maximum efficiency in high humidity or high outside temperatures.

Starting the air conditioner early in the morning and giving it a "head start" on the expected high outdoor ambient will greatly improve its ability to maintain the desired indoor temperature.

For a more permanent solution to high heat gain, accessories like A&E outdoor patio and window awnings will reduce heat gain by removing the direct sun. They also add a nice area to enjoy company during the cool of the evening.

### D. Condensation

**Note:** The manufacturer of this air conditioner will not be responsible for damage caused by condensed moisture on ceilings or other surfaces. Air contains moisture and this moisture tends to condense on cold surfaces. When air enters the RV, condensed moisture may appear on the ceiling, windows, metal parts, etc. The air conditioner removes this moisture from the air during normal operation. Keeping doors and windows closed when this air conditioner is in operation will minimize condensed moisture on cold surfaces.

# SPECIFICATIONS

Model No.	Nominal Capacity (BTU/HR) Cooling	Electrical Rating	Compressor Rated Load Amps	Compressor Locked Rotor Amps	Fan Motor Rated Load Amps	Fan Motor Locked Rotor Amps	SCFM-High Speed Max/Min	Total Static Max/Min W.C.	Refrigerant R-22 (Oz.)	Minimum Wire Size*	AC Circuit Protection ***User Supplied	Installed Weight (Pounds)	Minimum Generator Size** 1Unit/2Units
620615.321	13,500	115 VAC,	124	60.0	3.1	8.8	335/250	0.12/0.65	15.5	12AWG	20Amp	100	3.5KW/5.0KW
620615.326	13,500	60 Hz., 1 PH	124	60.0	3.1	8.8	335/250	0.12/0.65	15.5	Copper	20Amp	100	3.5KW/5.0KW
620625.321	13,500		124	60.0	3.1	8.8	335/250	0.12/0.65	15.5	Up To 24'	20Amp	100	3.5KW/5.0KW
620625.326	13,500		124	60.0	3.1	8.8	335/250	0.12/0.65	15.5		20Amp	100	3.5KW/5.0KW
620626.321	15,000		120	64.0	3.3	8.5	380/250	0.12/0.65	21.5		20Amp	100	3.5KW/5.0KW
620626.326	15,000		120	64.0	3.3	8.5	380/250	0.12/0.65	21.5		20Amp	100	3.5KW/5.0KW

\* For wire length over 24 ft., consult the National Electric Code for proper sizing.  
 \*\* Dometic Corporation gives **GENERAL** guidelines for generator requirements. These guidelines come from experiences people have had in actual applications. When sizing the generator, the total power usage of your recreational vehicle must be considered. Keep in mind generators lose power at high altitudes and from lack of maintenance.  
 \*\*\* **CIRCUIT PROTECTION:** Time Delay Fuse or HACR Circuit Breakers Required.

## INSTALLATION INSTRUCTIONS

### A. Precautions

#### **⚠ WARNING**

Improper installation may damage equipment, could endanger life, cause serious injury and/or property damage.

1. Read Installation and Operating instructions carefully before attempting to start your air conditioner installation.
2. Dometic Corporation will not be liable for any damages or injury incurred due to failure in following these instructions.
3. Installation must comply with the National Electrical Code ANSI/NFPA-70 and CSA Standard C22.1 (latest edition) and any State or Local Codes or regulations.
4. **DO NOT** add any devices or accessories to this air conditioner except those specifically authorized by Dometic.
5. This equipment must be serviced by qualified personnel and some states require these people to be licensed.

### B. Choosing Proper Location For The Air Conditioner

This air conditioner is specifically designed for installation on the roof of a recreational vehicle (RV). When determining your cooling requirements, the following should be considered:

- Size of RV;
  - Window area (increases heat gain);
  - Amount of insulation in walls and roof;
  - Geographical location where the RV will be used;
  - Personal comfort level required.
1. Normal Location-The air conditioner is designed to fit over an existing roof vent opening. When the vent is removed, it normally creates a 14-1/4" X 14-1/4" ( $\pm 1/8$ ") opening.

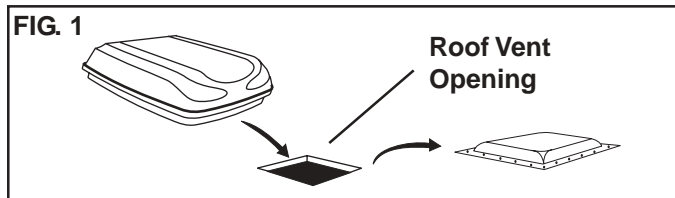

2. Other Locations-When no roof vent is available or another location is desired, the following is recommended:
  - a. For one unit installation: The air conditioner should be mounted slightly forward of center (front to back) and centered from side to side.
  - b. For two unit installations: Install one Air Conditioner 1/3 and one Air Conditioner 2/3's from front of RV and centered from side to side.

FIG. 2

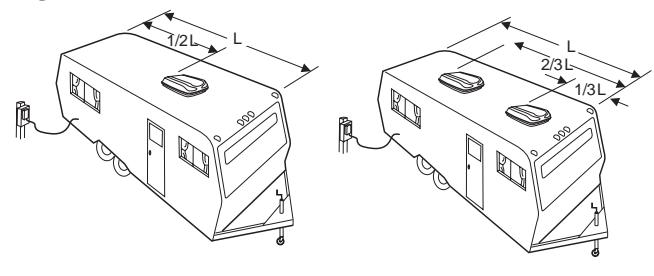

It is preferred that the air conditioner be installed in a relatively **flat and level** roof section measured with the RV parked on a level surface.

**Note:** A 8° slant to **either** side, or front to back, is acceptable for 620615, 620625 & 620626 series.

3. After Location Has Been Selected:
  - a. Check for obstructions in the area where air conditioner will be installed. See FIG. 3 & 4.
  - b. The roof must be designed to support 130 pounds when the RV is in motion. Normally a 200 lb. static load design will meet this requirement.

#### **CAUTION**

It is the responsibility of the installer of this air conditioner system to ensure structural integrity of the RV roof. Never create a low spot on the roof where water will collect. Water standing around the air conditioner may leak into the interior causing damage to the product and the RV.

- c. Check inside the RV for return air cover obstructions (i.e. door openings, room dividers, curtains, ceiling fixtures, etc.) See FIG. 3 & 4.

FIG. 3

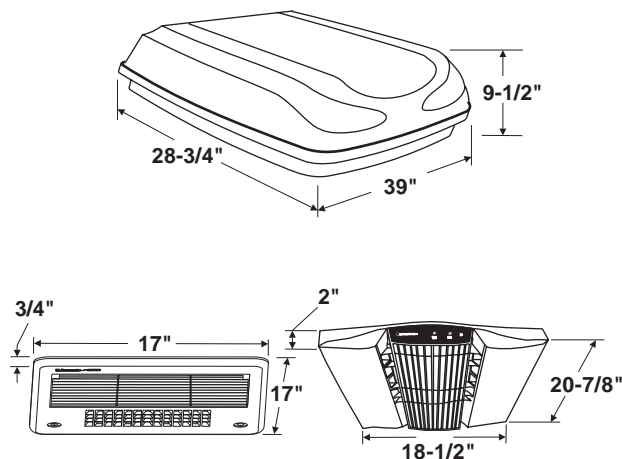

**FIG. 4 AIR CONDITIONER DIMENSIONS  
(On Top Of Vehicle)**

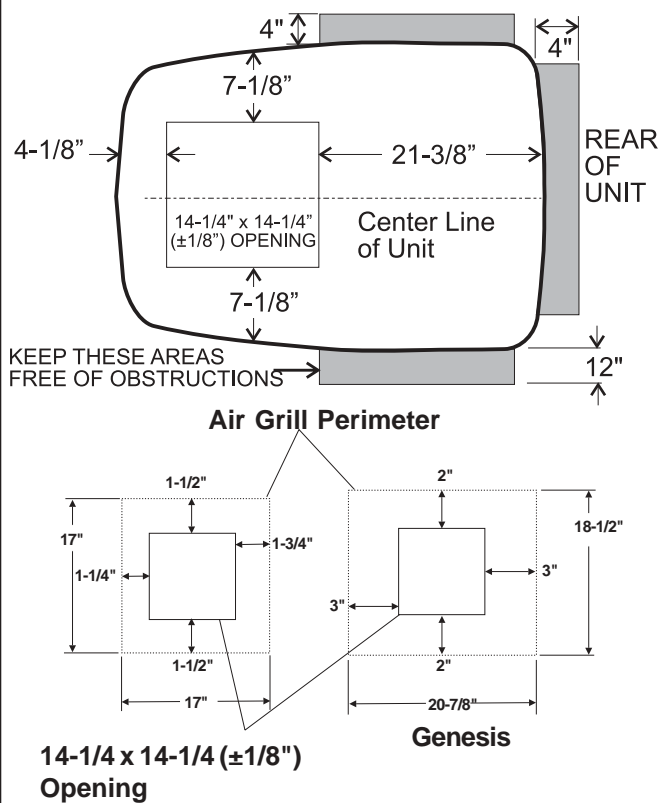

### C. Roof Preparation

1. Opening Requirements - Before preparing the ceiling opening, the type of system options must be decided upon. If a furnace is to be connected, wires must be run from the furnace to the Dometic A/C. Read all of the following instructions before beginning the installation.

If a roof vent opening will not be used a 14-1/4" x 14-1/4" (±1/8") opening must be cut through the roof and ceiling of the RV. This opening must be located between the roof reinforcing members.

#### **⚠ WARNING**

There may be electrical wiring between the roof and the ceiling. Disconnect 115 volt AC power cord and the positive (+) 12 volt DC terminal at the supply battery. Failure to follow this instruction may create a shock hazard causing death or severe personal injury.

The 14-1/4" x 14-1/4" (±1/8") opening is part of the return air system of the Air Conditioner and must be finished in accordance with NFPA Standard 501C Section 2.7.2.

### 2. Roof Vent Removal

- a. Unscrew and remove the roof vent.
- b. Remove all caulking compound around opening.

**FIG. 5**

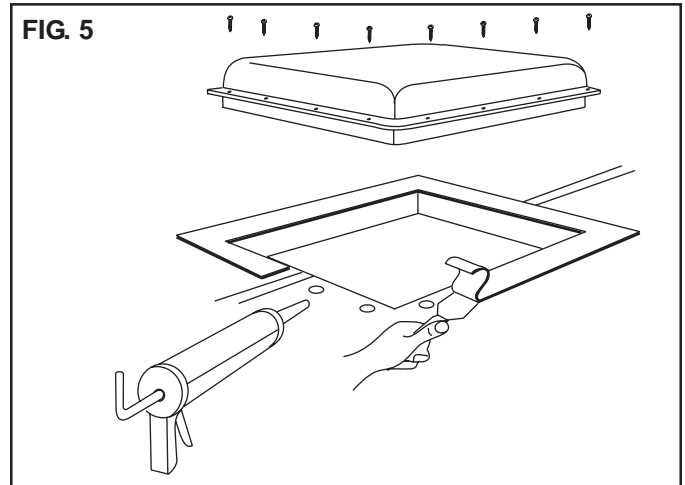

- c. Seal all screw holes and seams where the roof gasket is located. Use a good grade of all weather sealant.
  - d. If the opening exceeds 14-3/8" x 14-3/8", it will be necessary to install spacers.
  - e. If the opening is less than 14-1/8" x 14-1/8", it must be enlarged.
3. New Opening-(Installation Other Than Vent Opening)
    - a. Mark a 14-1/4" x 14-1/4" (±1/8") square on the roof and carefully cut the opening.
    - b. Using the roof opening as a guide, cut the matching hole in the ceiling.
    - d. The opening created must be framed to provide adequate support and prevent air from being drawn from the roof cavity. Lumber 3/4" or more in thickness must be used. Remember to provide an entrance hole for power supplies, furnace wiring and a four-conductor control cable.

**FIG. 6**

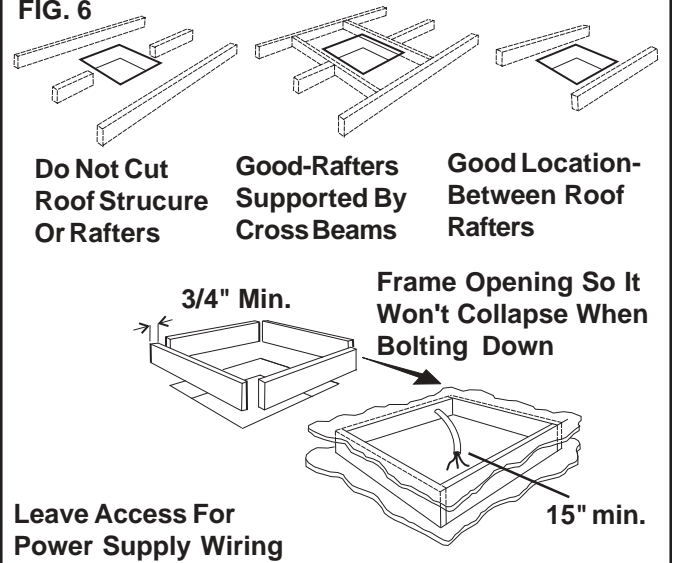

**CAUTION**

It is the responsibility of the installer of this air conditioner system to ensure structural integrity of the RV roof. Never create a low spot on the roof where water will collect. Water standing around the air conditioner may leak into the interior causing damage to the product and the RV.

4. Air Distribution System Sizing & Design (See Chart On Page 15)

**CAUTION**

It is the responsibility of the installer to insure the duct-work will not collapse or bend during and after the installation. Dometic Corporation will not be liable for roof structural or ceiling damage due to improperly insulated, sealed or collapsed duct-work.

The Installer of this air conditioner system must design the air distribution system for this particular application. Several requirements for this system **MUST** be met for the air conditioner to operate properly. These requirements are as follows:

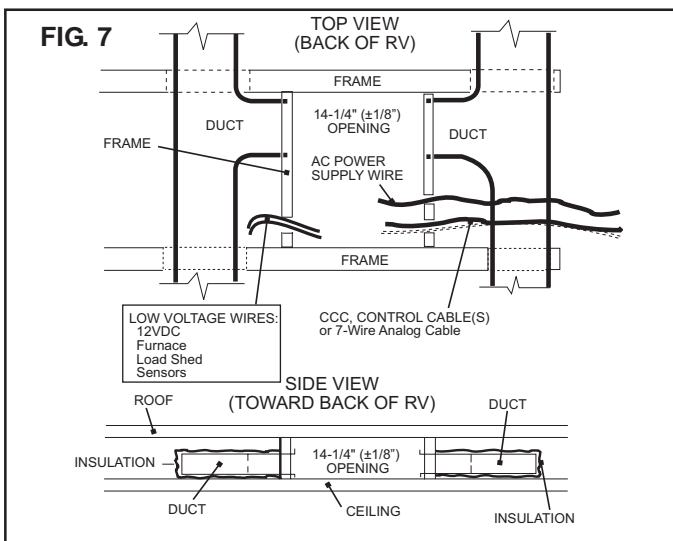

- The duct material must meet or exceed any agency or RVIA Standard that may be in existence at the time the RV is produced.
- All discharge air ducts must be properly insulated to prevent condensation from forming on their surfaces or adjacent surfaces during operation of the air conditioner. This insulation must be R-7 minimum.
- Ducts and their joints must be sealed to prevent condensation from forming on adjacent surfaces during operation of the air conditioner.
- Return air openings must have 40 square inches minimum free area including the filter.

- Return air to the air conditioner must be filtered to prevent dirt accumulation on air conditioner cooling surface.
5. Air Distribution System Installation
- Dometic Corporation recommends the basic configuration shown on page 16, for installing this air conditioner system. We have found by testing, that this configuration works best in most applications of this air conditioner system. It is the responsibility of the Installer of this system to review each RV floor plan and determine the following:
    - Duct size
    - Duct layout
    - Register size
    - Register location
    - Receiver location

These items must be determined in conjunction with the Air Distribution System and Sizing and Design Requirements listed in the chart on page 15. Terminate the start of the duct at the back edge of the 14-1/4" x 14-1/4" ( $\pm 1/8$ " opening)

**Important: Alternate configurations and methods may be used which still allow the air conditioner to operate properly; however, these alternate configurations and methods must be approved by the Dometic Corporation in writing. The following instructions are based upon the use of Dometic Return Air Kits 3105007.XXX, 3105935.XXX, or 3308120.XXX Genesis Air Filtration System. The 3107180.006 Bolt/Cover Kit has the mounting bolts and cover for the AC junction box for use with these kits.**

**D. Wiring Requirements**

- Route a copper 12 AWG, with ground, 115 VAC supply line from the fuse or circuit breaker box to the roof opening.
  - This supply line must be located in the front portion of the 14-1/4" x 14-1/4" ( $\pm 1/8$ ") opening.
  - The power **MUST** be on a separate 20 Amp time delay or HACR circuit breaker.
  - Make sure that at least 15" of supply wire extends into the roof opening. This ensures easy connection at the junction box.
  - Wiring must comply with all National, State and Local Wiring Codes.
  - Use a steel sleeve and a grommet or equivalent methods to protect the wire where it passes into the opening.
- Route a dedicated 12 VDC supply line (18-22 AWG) from the RV's converter or battery to the roof opening.
  - This supply line must be located in the front portion of the 14-1/4" x 14-1/4" ( $\pm 1/8$ ") opening.
  - Make sure that at least 15" of supply wire extends into the roof opening.

3. If system includes a gas furnace, route two 18 gauge thermostat wires from the furnace to the 14-1/4" x 14-1/4" ( $\pm 1/8$ ") roof opening of the air conditioner that will control it. Make sure that at least 15" of the wire extends into the roof opening. If more than one furnace is to be used, route the second set of thermostat wire to the second air conditioner.
4. Route a 4-conductor control cable from the **Receiver** mounting position into the 14-1/4" x 14-1/4" ( $\pm 1/8$ ") roof opening. Make sure that at least 15" of the wire extends into the roof opening and 6" extend from the wall at the mounting position of the **Receiver**. See Section E-2.

## E. Receiver & Cable Installation

**Note:** The receiver monitors the temperature of the living area. The following receiver location is recommended to maintain the selected temperature setting. Any other location must be approved by Dometic. See FIG.30.

1. Locate the receiver in a front to rear position on the ceiling, and to one side or the other of the return air cover. See FIG. 8A, 8B & 8C. Mounting the receiver from side to side is not recommended, but could be mounted this way as a last possibility.

**Note:** When used with the 3308120 Genesis Filtration System, do not mount the receiver where it will interfere with the filter removal. See FIG. 8A. When used with the 3105935 Quick Cool Return Air Grille do not install near the discharge air duct. See FIG. 8C.

**Note:** To operate the air conditioner, the receiver must be installed in a location that will allow the remote to be in the line of sight of the receiver.

- a. If another receiver mounting location is anticipated, observe the following general rules in determining the location and submit location to Dometic for approval.
  - Locate the Receiver 54" above the floor.
  - **NEVER** expose it to direct heat from lamps, sun or other heat producing items.
  - Avoid locations close to doors that lead outside, windows or adjoining outside walls or directly under cabinets or overhangs which limit air movement.
  - Avoid locations close to supply registers and the air from them.
  - **NEVER** locate receiver in a room that is warmer or cooler than the rest of the RV.
  - The major living area is normally a good location.

### 2. Control Cable Installation

A 4-conductor control cable must be routed from the roof opening to the **Receiver**:

- a. Choose the shortest, most direct route from the 14-1/4" x 14-1/4" ( $\pm 1/8$ ") opening to the **Receiver** location selected. Leave 6" of cable extending through the wall. See Section D-4.
- b. The control cable that should be used is a flat, 4-conductor telephone cable.

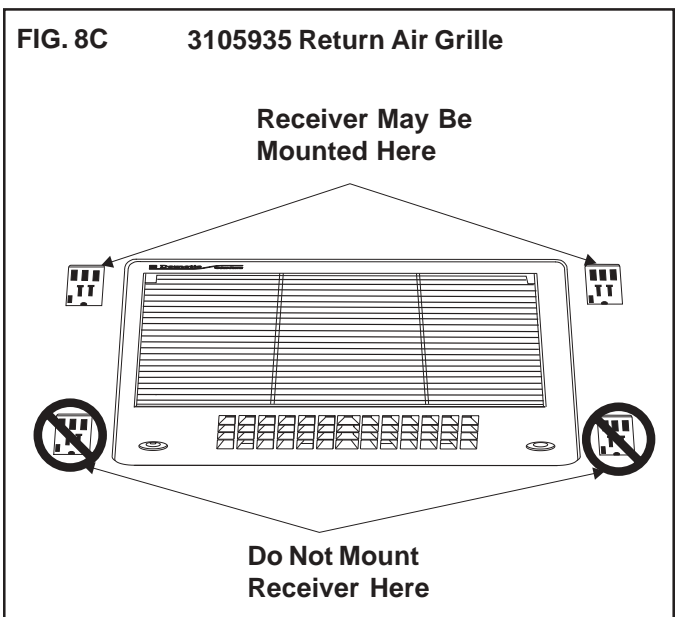
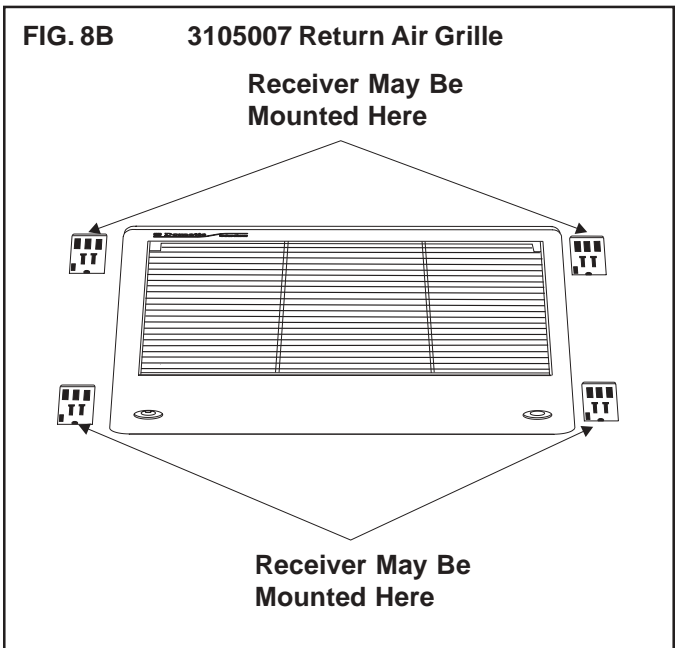
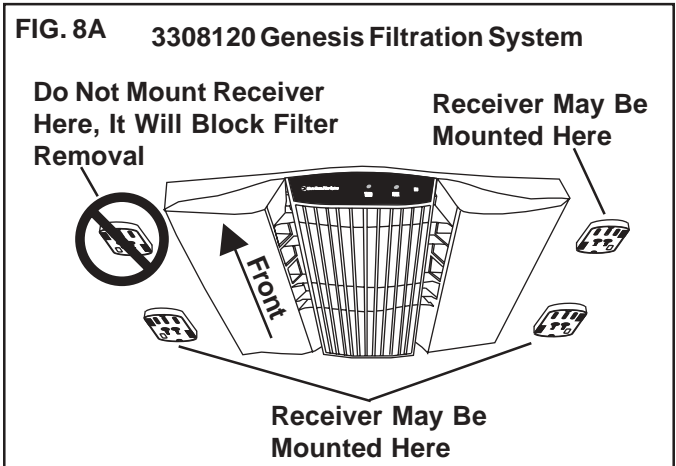

- c. The control cable must be terminated with two (2) RJ-11 telephone connectors. Refer to the crimp tool manufacture for crimping instructions.

**Important:** RJ-11 connectors must be installed as shown in FIG. 9A & 9C.

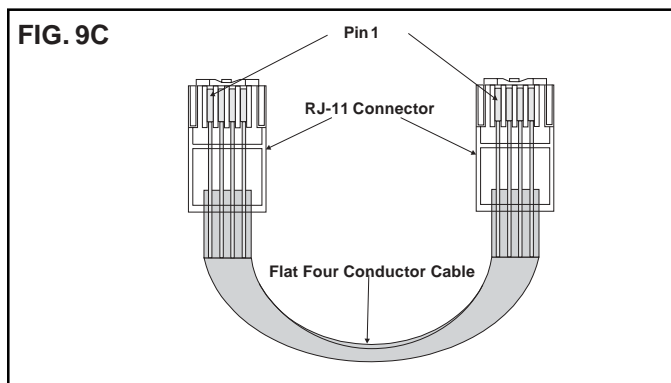
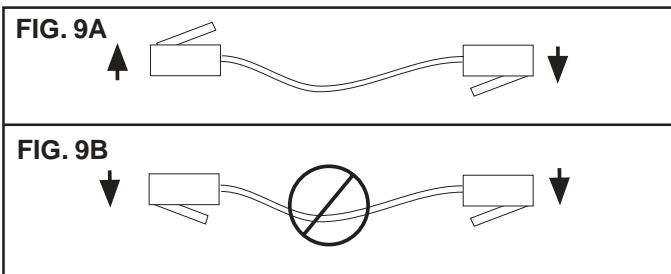

**F. Placing The Air Conditioner On The Roof.**

1. Remove the air conditioner from the carton and discard carton.
2. Place the air conditioner on the roof.

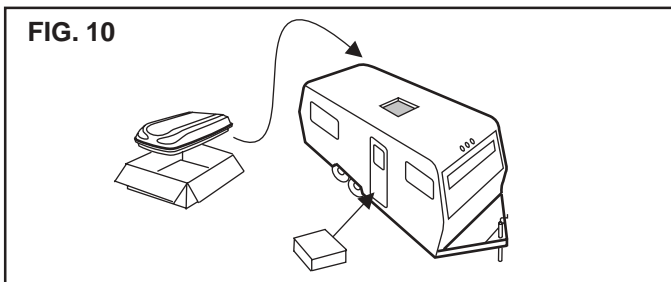

**⚠ CAUTION**

**This unit weighs approximately 100 pounds. To prevent back injury, use a mechanical hoist to place Air Conditioner on roof.**

3. Lift and place the unit over the prepared opening using the gasket on the unit as a guide.

**CAUTION**

**Do not slide the unit. This may damage the neoprene gasket attached to the bottom and may create a leaky installation.**

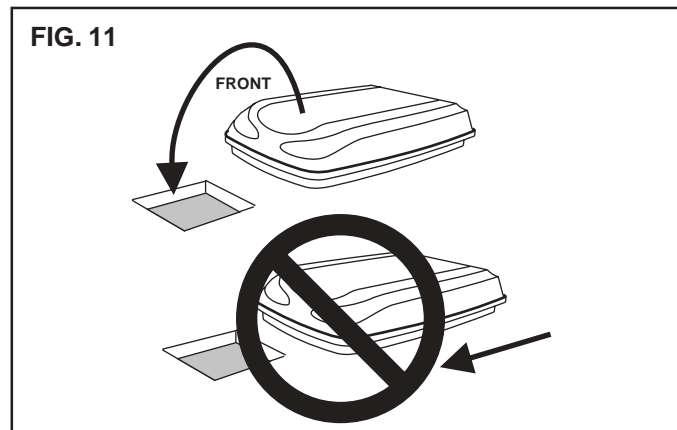

4. Place the return air kit inside the RV. This box contains mounting hardware for the air conditioner and will be used inside the RV. This completes the outside work, Minor adjustments can be done from inside of the RV if required.

**G. Installing Air Conditioner**

■ **Installing unit with 3105007.XXX or 3105935.XXX Return Air Cover. For unit with Genesis Air Filtration System see page 10.**

1. Installation Of Ceiling Template
  - a. Check gasket alignment of the air conditioner over the roof opening and adjust if necessary. Unit may be moved from below by slightly lifting. See FIG. 12.

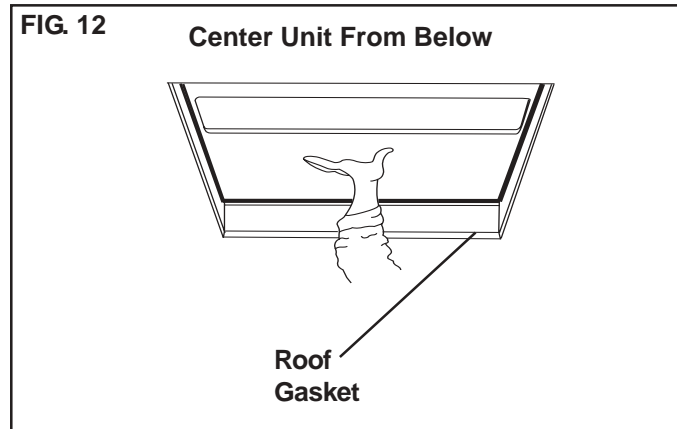

- b. Remove return air cover and ceiling template from the 3105007.XXX or 3105935.XXX kit carton.



FIG. 13

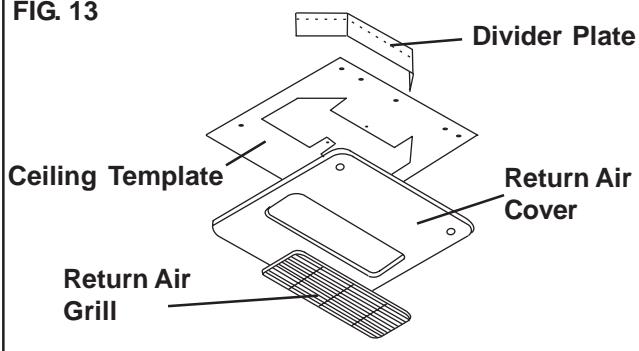

- c. Locate the four 8" x 1/4" x 20 unit mounting bolts, junction box cover and Romex connector in the 3107180.006 bolt kit.
- d. Reach up into the return air opening and pull the unit electrical cord down. Mount the junction box with screws to the framing in front of the 14-1/4" x 14-1/4" ( $\pm 1/8$ ") opening. See FIG. 15.

FIG. 14

## Center Unit From Below

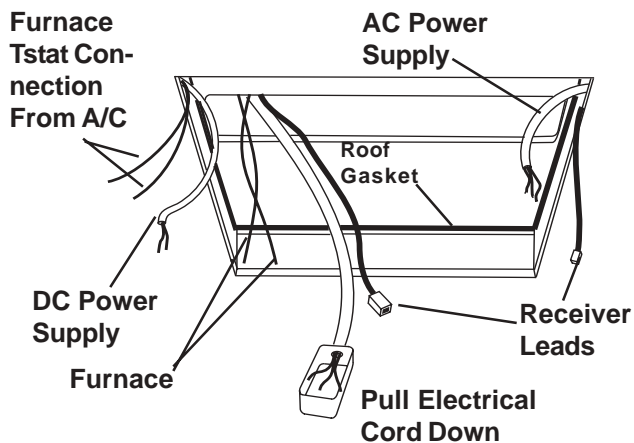
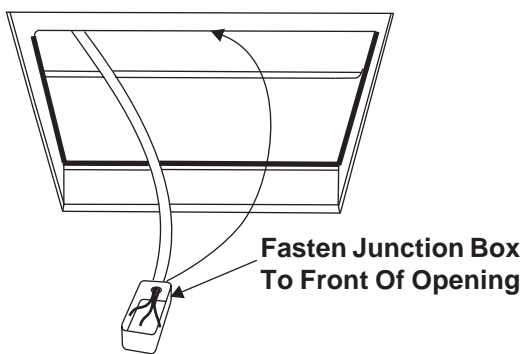

FIG. 15



- e. Install the Romex connector in the junction box.
- f. Hold the ceiling template up to the 14-1/4" x 14-1/4" ( $\pm 1/8$ ") opening. Be sure the large plate faces the rear of the RV.
  - Start each mounting bolt through the ceiling template and up into the unit base pan by hand. Install wood screw in each end of the ceiling template. This insures a tight fit of the return air cover to ceiling. See FIG. 16.

- **EVENLY** tighten the bolts to a torque of 40 to 50 inch pounds. This will compress the roof gasket to approximately 1/2". The bolts are self locking so over tightening is not necessary. See FIG. 16.

**CAUTION**

If bolts are left loose there may not be adequate roof seal or if over tightened, damage may occur to the air conditioner base or ceiling template. Tighten to specifications listed in this manual.

FIG. 16

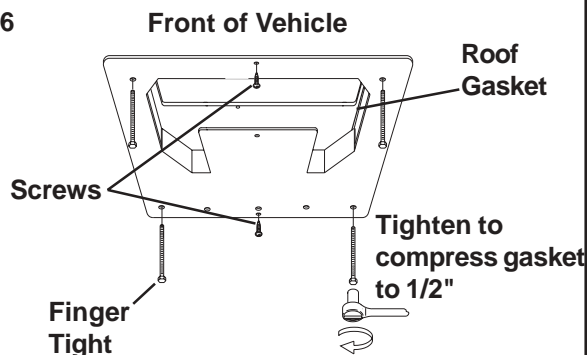

2. Installation Of Divider Plate
  - a. Measure the ceiling to roof thickness:
    - If distance is 2.0" - 3-3/4", remove perforated tab from divider plate.
    - If distance is 3-3/4" - 5-1/2", remove no tabs.
  - b. Remove the backing paper from double sided tape located on ceiling template. See FIG. 17.

FIG. 17

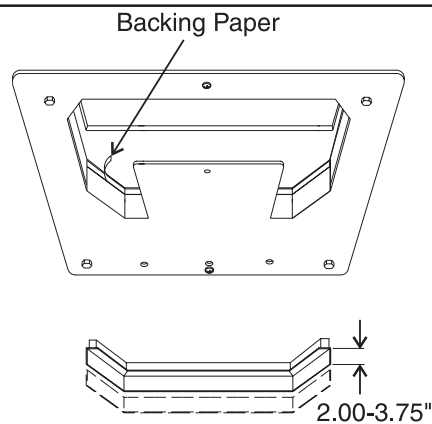

- c. Place divider plate up to bottom of air conditioner base pan firmly. The foam tape on the divider plate must seal to bottom of base pan. See FIG. 18.

**CAUTION**

Improper installation and sealing of divider plate will cause the compressor to quick cycle on the cold control. This may result in fuse or circuit breaker opening and/or lack of cooling.

FIG. 18

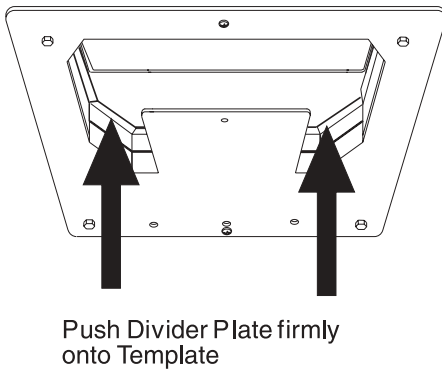

**Note:** The adhesive on the insulation is extremely sticky. Be sure the part is located where desired before pressing into place.

- d. With slight pressure then push the divider plate against the double sided tape on the ceiling template.
- e. Locate the 1/8" x 7" x 18" self-adhesive insulation supplied with the return air kit. Remove the backing paper from the insulation and carefully stick onto the ceiling template divider panel. See FIG. 19.

FIG. 19

Place insulation in position  
(Do not Cover unit rating plate)

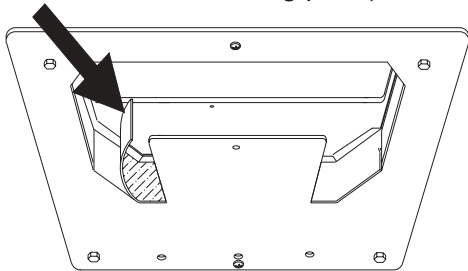

- Excess width is intended to seal the divider plate to the sides of the 14-1/4" x 14-1/4" ( $\pm 1/8$ ") opening. This is to help prevent cold air discharge from circulating into the air conditioner return air opening.
- If the insulation is too high, stick excess height of insulation to the air conditioner base pan. Do not cover up unit rating plate.

- Installing unit with 3308120.XXX Genesis Air Filtration System Return Air Kit. For unit with 3105007.XXX or 3105935.XXX Return Air Kit, see page 8.

FIG. 20

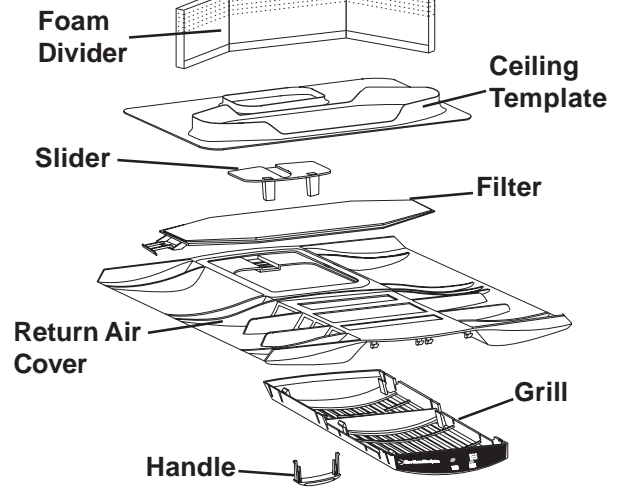

## 1. All Non-Center Duct Installations

**Note:** The Genesis Air Filtration System can be installed on the units that use a center discharge duct through the 14-1/4" x 14-1/4" ( $\pm 1/8$ ") opening. Installing units with the center discharge duct go to page 11 "Section 2" Center Duct Installation.

- a. Check gasket alignment of the air conditioner over the roof opening and adjust if necessary. Unit may be moved from below by slightly lifting. See FIG. 12.
  - Remove return air cover, ceiling template, foam divider and air filter from the 3308120 carton.
  - Locate the four 8" x 1/4" x 20 unit mounting bolts, junction box cover and Romex connector in the 3107180.006 bolt kit.
  - Pull down the unit's electrical cord and fasten the junction box with screws to the framing in the front of the 14-1/4" x 14-1/4" ( $\pm 1/8$ ") opening. See FIG. 14 & 15.
  - Install the Romex connector in the junction box.
- b. Installing Foam Divider
  - Locate the foam divider and insert it corner to corner in the 14-1/4" x 14-1/4" ( $\pm 1/8$ ") opening with the adhesive tape up. (Do not remove paper to expose adhesive). The foam divider should be level with the ceiling ( $\pm 1/4$ "). Tear off the excess at the pre-cut perforations in divider. See FIG. 21.

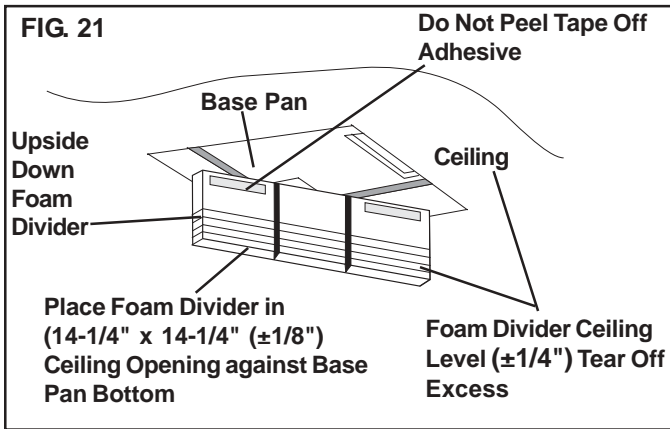

c. Install Ceiling Template

- Peel the paper off of the foam divider and stick it in place on the center of the rear flange of the return air opening on the ceiling template. See FIG. 22.

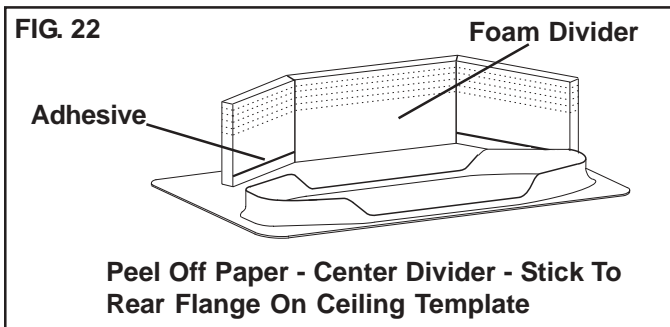

- Start each mounting bolt through the ceiling template and up into the unit base pan by hand.
- **EVENLY** tighten the bolts to a torque of 40 to 50 inch pounds. This will compress the roof gasket to approximately 1/2". The bolts are self locking so over tightening is not necessary. See FIG. 16.

**CAUTION**

If bolts are left loose there may not be adequate roof seal or if over tightened, damage may occur to the air conditioner base or ceiling template. Tighten to specifications listed in this manual.

- d. Use Aluminum foil tape (not supplied) to seal the ends of the foam divider to the sides of the opening. Make sure the area behind the flange on the ceiling template is sealed. See FIG. 23.

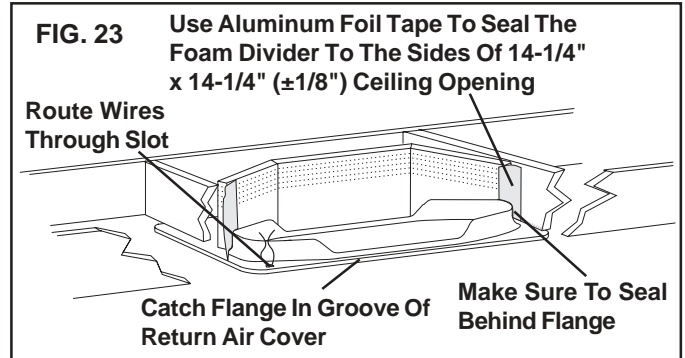

**CAUTION**

Improper installation and sealing of foam divider will cause the compressor to quick cycle on the cold control. This may result in fuse or circuit breaker opening and/or lack of cooling.

2. Center Discharge Duct Application Installation

**Note:** If using non-center duct installation, refer to all Non-Center Duct Installations Section 1 on page 10.

**Important:** A duct adapter (not supplied) must be installed between the unit discharge and the customer installed center duct. This duct adapter must be approved by Dometic.

- Check gasket alignment of the air conditioner over the roof opening and adjust if necessary. Unit may be moved from below by slightly lifting. See FIG. 12.
  - Remove return air cover, ceiling template, foam divider and air filter from the 3308120 carton.
  - Locate the four 8" x 1/4 x 20 unit mounting bolts, junction box cover and Romex connector in the 3107180.006 bolt kit.
  - Pull down the unit's electrical cord and fasten the junction box with screws to the framing in the front of the 14-1/4" x 14-1/4" ( $\pm 1/8$ ") opening. See FIG. 14 & 15.
  - Install the Romex connector in the junction box.
- Installing Foam Divider
  - Cut notch in the center section of the foam divider to fit (approximately 2 x 8 inches) snugly around duct. See FIG. 24.

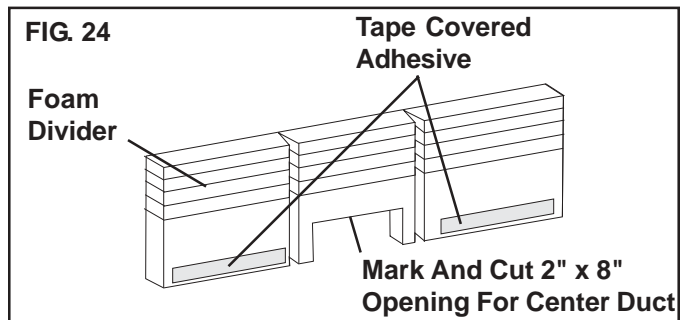

- Place the foam divider in the return air opening above the center duct before ceiling template.
- c. Install Ceiling Template
- Apply a piece of foam weather stripping (not supplied) to the upper side of ceiling template to make a seal between it and the duct. Use a soft piece of foam weather strip 1 x 3/4 x 10 inches. See FIG. 25.

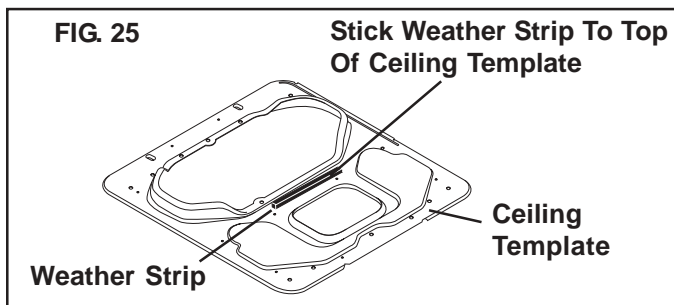

- Start each mounting bolt through the ceiling template and up into the unit base pan by hand.
- EVENLY** tighten the bolts to a torque of 40 to 50 inch pounds. This will compress the roof gasket to approximately 1/2". The bolts are self locking so over tightening is not necessary. See FIG. 16.

### CAUTION

If bolts are left loose there may not be adequate roof seal or if over tightened, damage may occur to the air conditioner base or ceiling template. Tighten to specifications listed in this manual.

- d. Use Aluminum foil tape (not supplied) to seal the ends of the foam divider to the sides of the opening. Make sure the area behind the flange on the ceiling template is sealed. See FIG. 23.

### CAUTION

Improper installation and sealing of foam divider will cause the compressor to quick cycle on the cold control. This may result in fuse or circuit breaker opening and/or lack of cooling.

- e. Cut the opening in the center duct using the discharge opening in the ceiling template for a pattern. Seal the center duct to the ceiling template using foil tape, foam insulation or silicon sealant.

## H. Wiring The System

Reach up into the return air opening and pull the remaining wires down.

- Connection Of Low Voltage Wires

### CAUTION

Disconnect the positive (+) 12 volt DC terminal at the supply battery. Damage to equipment could occur if the 12 volt DC is not shut off.

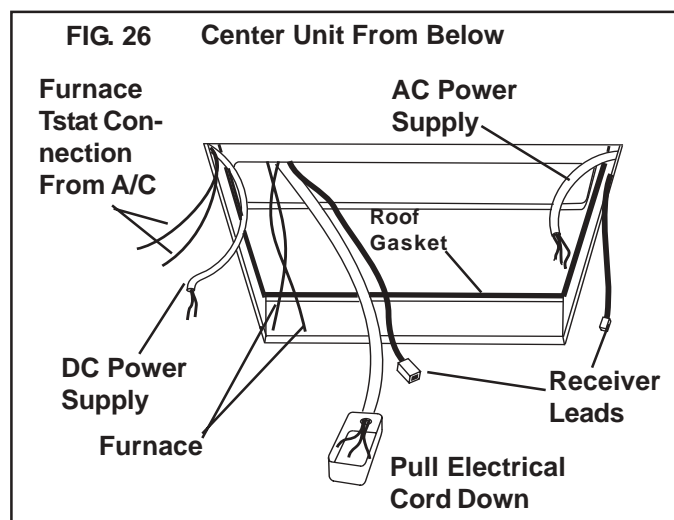

- Connect the previously run 12 VDC to the red and black wires protruding from the units return air opening. Connect +12 VDC to the red wire; -12 VDC to the black wire. (Do not connect wires if using the 3308120.XXX Genesis Air Filtration System Return Air Kit.) See Section I Decorative Cover Installation (Installing unit with 3308120.XXX Genesis Filtration System Return Air Kit).
- Connect the previously run furnace thermostat wires (if applicable) to the blue/white wires protruding from the units return air opening. The polarity of these connections does not matter.
- Connect the receiver flat four conductor control cable previously terminated (see Section E-2. Control Cable) into one of the receiver leads out of the air conditioner. Either one of the two (2) receiver cables can be used.
- Insert the receiver cable into the receiver and mount it in the desired location. See FIG. 14.

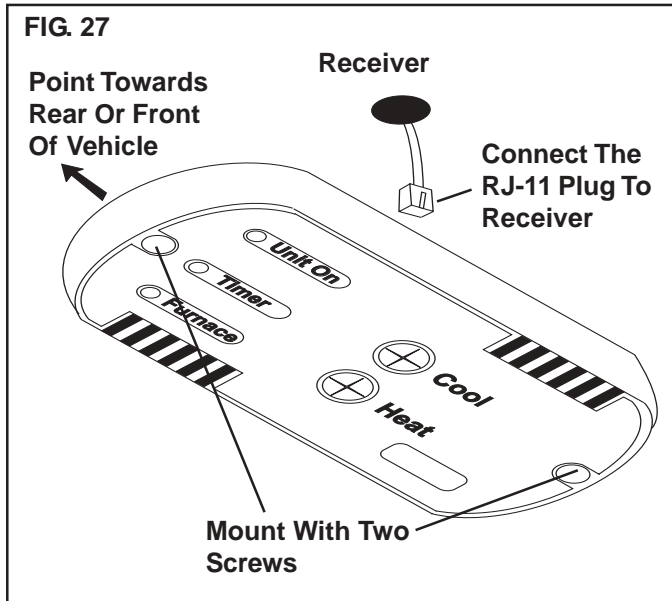

## 2. Connection Of 115 Volt Power Supply

### **! WARNING**

**Disconnect 115 volt AC. Failure to follow these instructions could create a shock hazard causing death or severe personal injury.**

- a. Route power supply line through Romex connector into junction box on side away from the ceiling template. Tighten connector.

### **! WARNING**

**This product is equipped with a 3-wire (grounded) system for protection against shock hazard. Make sure that the product is wired into a properly grounded 115 volt AC circuit and the polarity is correct. Failure to do so could result in death, personal injury or damage to the equipment.**

- b. Connect white to white; black to black; and green to green or bare copper wire using appropriate sized twist connectors.
- c. Tape the twist wire connectors to the supply wire to assure they don't vibrate off.
- d. Push the wires into the box.
- e. Install the cover onto the junction box.

## I. Decorative Cover Installation

- **Installing unit with 3105007.XXX or 3105935.XXX Return Air Cover. For Genesis Air Filtration System Return Air Kit See Page 14.**

**Note:** On models equipped with a solar panel, see wiring instructions for the solar panel before proceeding.

1. Remove the return air grill from the return air cover.
2. Place the return air cover up to the ceiling template.
3. Install cover to template with #8 x 3/8" blunt point Phillips head screws provided (6 required).
4. Reinstall filter return air grill into return air cover. Align tabs with mating notches and snap into place.
5. Install two hole plugs into screw holes in back of return air cover. See FIG. 28.

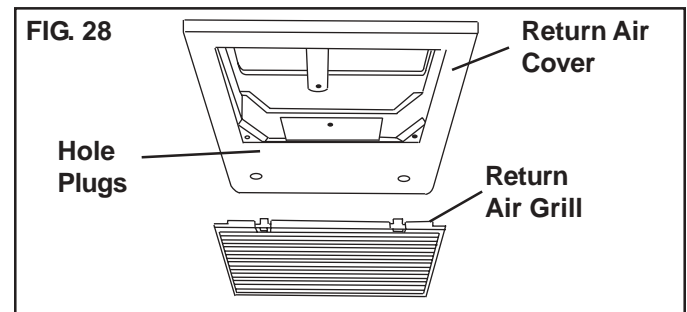

6. This completes the installation of the air conditioner. We recommend that power be supplied to the air conditioner and check for proper operation. Refer to Operating Manual or User's Guide for a description of the air conditioner operation.

■ **Installing unit with 3308120.XXX Genesis Air Filtration System Return Air Kit. For 3105007.XXX or 3105935.XXX Return Air Kit See Page 13.**

**Note:** On models equipped with a solar panel, see wiring instructions for the solar panel before proceeding.

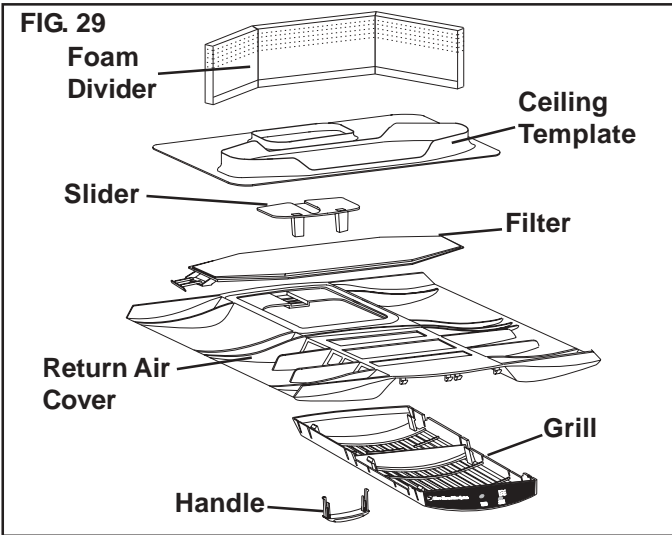

1. Install the slider in the return air cover and raise it to the ceiling template. See FIG. 29.
2. Route the wires from the return air cover through the template slot leaving about 3" between, and position wire here so they can be reached after plastic cover is installed. See FIG. 23.
3. Place the front of the return air cover against the ceiling and slide towards the rear. The flange on the ceiling template will catch in the groove on the return cover. Adjust the position (right to left) and install the front two screws. Start and tighten the remaining screws to hold it in place.
4. Connect together the wires from the thermostat, control box and filter indicator.
  - a. Connect the red wire from the air conditioner and the red wire from the filter indicator light with the red positive 12VDC supply wire. See FIG. 23.
  - b. Connect the black wire from the air conditioner and the black wire from the filter indicator light with the black negative 12VDC supply wire. See FIG. 23.

**Note:** Number 10 cabinet screw can be used to replace the two front screws to hold the plastic cover flush to the ceiling, if required.

5. Tighten the screws holding the return air cover. Slide the filter from the right side (looking toward the RV front) over the wires. Make sure the wires are secured above the filter and are out of its way.
6. Place grill on return air cover and snap in place. Decal is on end over circuit board.
7. Place slide handle through slots in grill into the slide posts. Handle will fit in either direction.

8. This completes the installation of the air conditioner. We recommend that power be supplied to the air conditioner and check for proper operation. Refer to Operating Manual or User's Guide for a description of the air conditioner operation.

## AIR DISTRIBUTION DUCT SIZING & DESIGN CHART

<b>Return Air Cover Model</b>	3105007.XXX 3105935.XXX	3308120.XXX Genesis Air Filtration System
<b>Roof Cavity Depth</b>	2.0 In. Min. - 5-1/2 In. Max.	2.0 In. Min. - 5-1/2 In. Max.
<b>Duct Cross Sectional Area</b>	21.0 Sq. In. Min.	32.0 Sq. In. Min.
<b>Duct Size</b> Depth Width Total Duct Length Duct Length (short run)	1-1/2 In. Min. - 2-1/2 In. Max. 7.0 In. Min. - 10.0 In. Max. 15.0 Ft. Min. - 40.0 Ft. Max. 1/3 Total Duct Length	2.0 In. Min. - 2-1/2 In. Max. 8.0 In. Min. - 10.0 In. Max. 15.0 Ft. Min. - 40.0 Ft. Max. 1/3 Total Duct Length
<b>Center Duct System (Only)</b> Depth Width Total Duct Length Duct Length (Short Run)		2.0" In. Min. - 2.0" Max. 8.0 In. Min. - 8.0 In. Max. 15.0 Ft. Min. - 40 Ft. Max. 1/3 Total Length
<b>Register Requirements</b> Number Required Per Run Register Free Air Area Distance From Duct End Distance From Elbow	4 Min. 14.0 Sq. In. 5.0 In. Min. - 8.0 In. Max. 15.0 In.	4 Min. 14.0 Sq. In. 5.0 In. Min. - 8.0 In. Max. 15.0 In.
<b>Duct Static</b> Blower at High Speed, Filter & Grill In Place	0.12 - 0.65 In. W.C.	0.12 - 0.65 In. W.C.

**Note:** Duct sizes listed are inside dimensions.

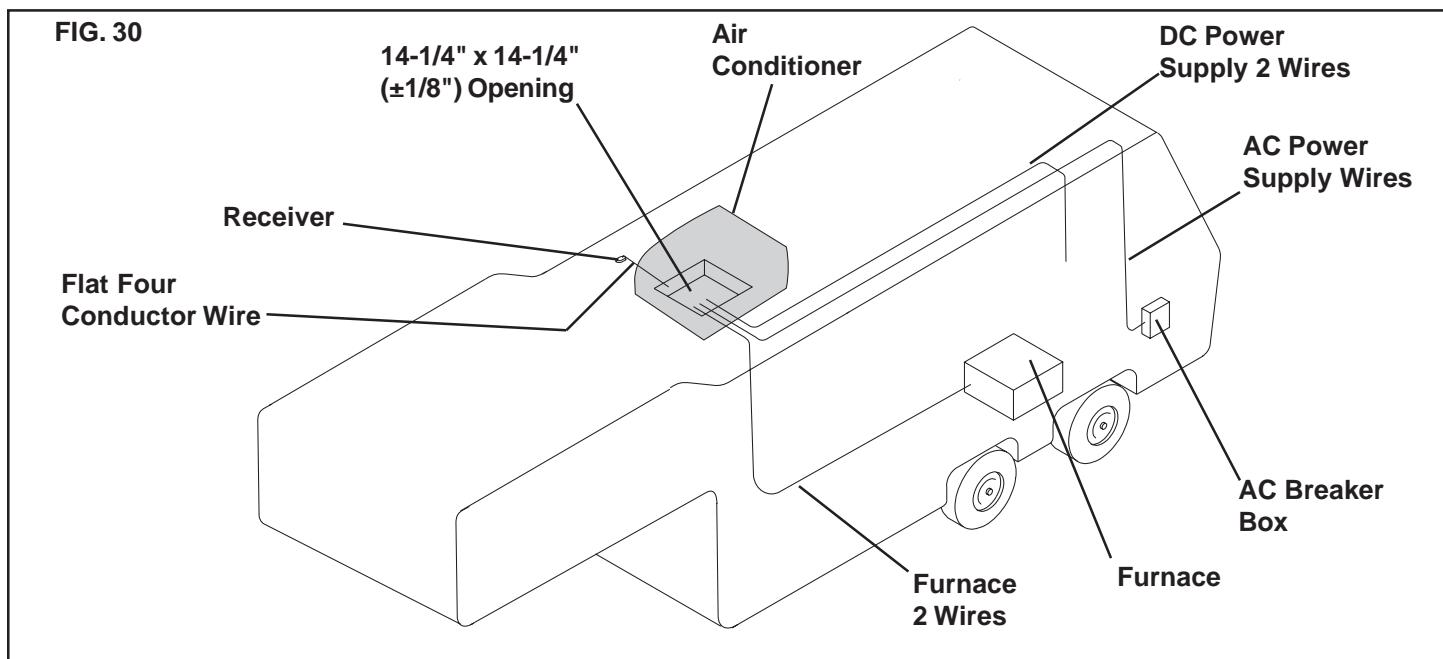

**FIG. 31 Duct Size And Requirements For 3105007.XXX And 3105935.XXX Return Air Cover**

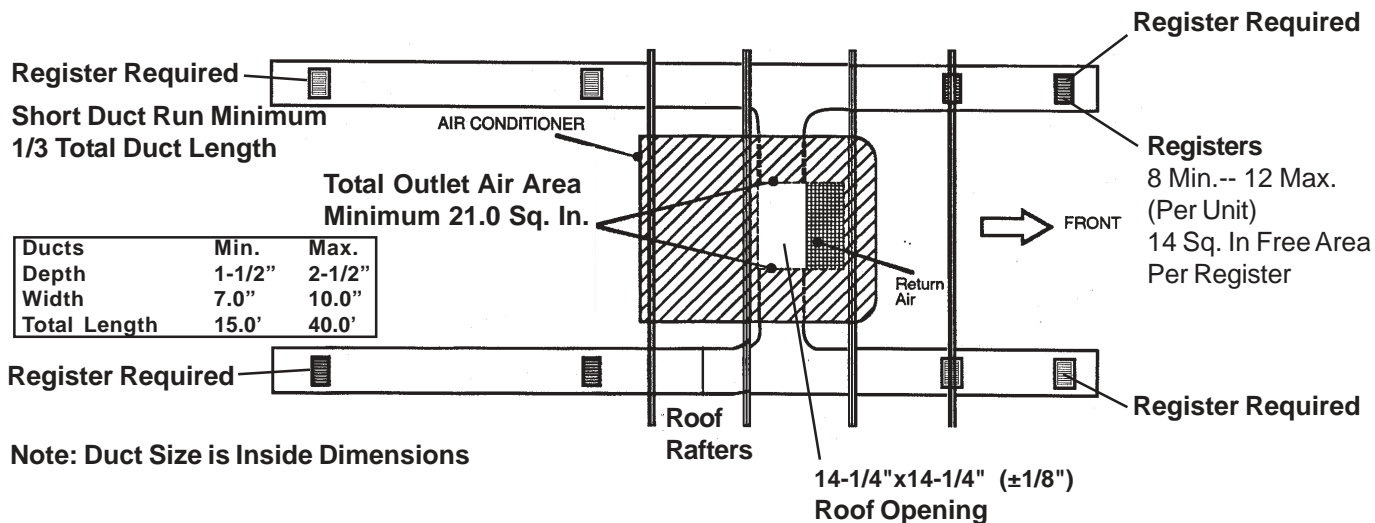

**FIG. 32 Duct Size And Requirements For 33308120.XXX Genesis Air Filtration System Kit**

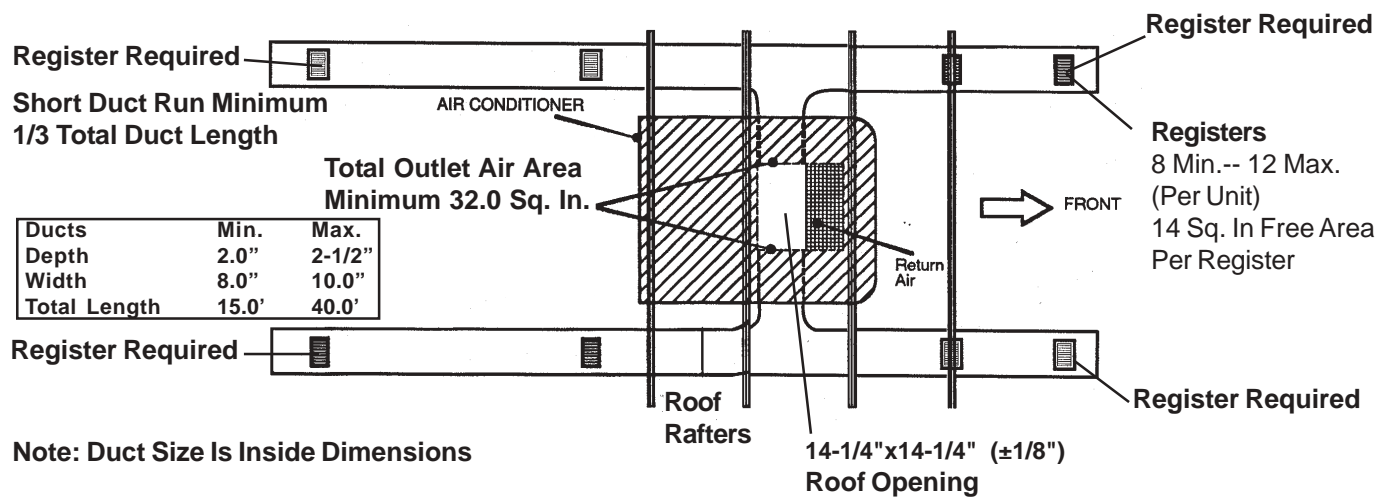



## OPERATING INSTRUCTIONS



### A. General Instructions

1. The remote uses 2 “AAA” batteries. It is recommended that a spare set of batteries be available.
2. All communications between the remote and receiver are validated when you hear a **tone** or **beep**.
3. The orange button turns the unit “ON” and “OFF”.



4. All changes require the hand held remote to be pointed at the receiver.
5. When settings are changed, you must hear the tone or beep to indicate the new settings are updated.
6. One of the LED's (GREEN, ORANGE or RED) will be illuminated on the receiver depending on the mode selected.
7. The receiver's Green LED will blink to alert the operator to the following:
  - One blink with one second interval, frost control active.
  - Two blinks with one second interval, DC voltage high (18VDC and over).
  - Three blinks with one second interval, DC voltage low (9.75 VDC or lower).
  - Blink **ON** for 1/2 second, **OFF** 1/2 second - See step 8 Delay Timer, Paragraph a.
8. Delay Timer (Present in all Modes)
  - a. The short-cycle delay is activated every time the compressor turns “OFF”. The timer will delay the compressor from restart until the 150 second time has elapsed.
  - b. Delay on start cycle is activated when ever the fan is tuned “ON”. A 15 second delay is started before the compressor or heat is turned “ON”.
  - c. Delay-on-off cycle is present when the compressor or heat is turned “OFF”. The fan will continue to operate for 15 seconds.
9. Low Battery
  - a. The low battery symbol will appear in the display window.
 
  - b. When the low battery condition exists, and the remote sends a signal to the receiver, it may be possible for the control system to go to the default setting (Cool Mode with 74° F set point). If this condition occurs replace the batteries.

### B. Cooling Operation

1. Push the “MODE” button until the cool symbol is displayed.
 
2. Select fan speed by pushing the “FAN” button until the desired fan speed is displayed.
  - a. **High Speed** (continuous fan, compressor cycles with thermostat)
 
  - b. **Low Speed** (continuous fan, compressor cycles with thermostat)
 



- c. **Auto High Speed** (fan & compressor cycle with the thermostat)

AUTO



- d. **Auto Low Speed** (fan & compressor cycle with the thermostat)

AUTO



3. Set the desired temperature by pushing the “UP(+)” or “DOWN(-)” button.
4. The receiver will **beep when each change is completed**. The **GREEN** LED will light.

### C. Furnace Operation (if equipped)

1. Push the “MODE” button until the furnace symbol is displayed.
 
2. Set the desired temperature by pushing the “UP(+)” or “DOWN(-)” button.
3. The receiver will **beep when each change is completed**. The **RED** LED will light.

### D. Dry - Air Operation

1. Push the “MODE” button until the dry - air symbol is displayed.
 
2. Set the desired temperature by pushing the “UP(+)” or “DOWN(-)” button.
3. The receiver will **beep when each change is completed**. The **GREEN** LED will light. See TIMER OPERATION.

**Note:** In this mode the receiver monitors the room temperature in relationship with the set point. If the temperature is 1 °F above the set point the compressor and low fan will cycle “ON” for 15 minutes and “OFF” for 3 minutes. If the room temperature drops below the set point the compressor and low fan will cycle “ON” for 6 minutes and “OFF” for 15 minutes until the set point is reached.

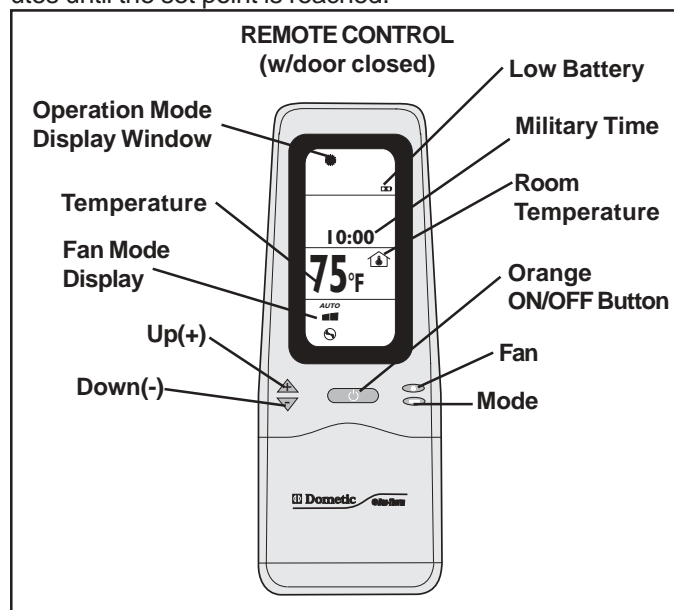

### E. Auto Change Operation

1. Push the “MODE” button until the auto change symbol is displayed. 
2. Set the desired temperature by pushing the “UP(+)” or “DOWN (-)” button.
3. The receiver will **beep when each change is completed**. The **GREEN** LED will light. See TIMER OPERATION.

**Note:** In the auto change mode the temperature will be maintained in the vehicle without the need to select cool or heat. A furnace or heat strip must be present and operational before this feature can operate. If the installation contains both a heat strip and furnace this feature **will not** select the furnace mode. Furnace mode must be selected manually. This mode should be used only in temperatures that will not require furnace operation.

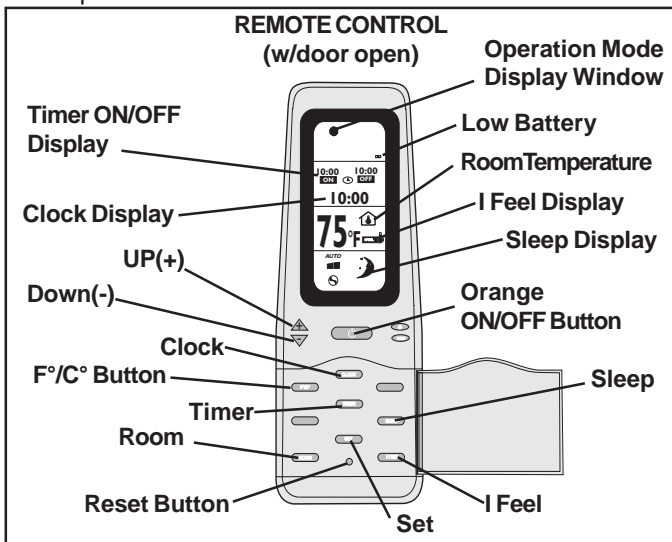

### F. Option Feature (electric heat strip - if equipped)

1. Push the “MODE” button until the heat symbol is displayed. 
2. Set the desired temperature by pushing the “UP(+)” or “DOWN (-)” button.
3. The receiver will **beep when each change is completed**. The **GREEN** LED will light.

### G. Fan Only Operation

1. Push the “MODE” button until the fan symbol is displayed. 
2. Select fan speed by pushing the “FAN” button until the desired fan speed is displayed.
  - a. **High Speed** (continuous fan operation)



### b. Low Speed (continuous fan operation)



3. The receiver will **beep when each change is completed**. The **GREEN** LED will light.

### H. Room Temperature Display

1. Press the “ROOM” button to display the temperature at the remote location.
2. The **Room** symbol will appear beside the temperature display.



### I. Sleep Operation

1. The cool, heat or furnace mode must be selected.
2. Set the temperature at the desired level, and push the sleep button. The sleep symbol will appear on the display and a **beep** will sound indicating that the unit is in **sleep mode**. See TIMER OPERATION.



**Note:** In the **sleep mode** the temperature will be offset by 2°F of the set point, which means, if the set point is 77 °F (during the cool operation) then in sleep mode it will automatically change to 79 °F. The sleep settings will become effective 2 hours after the sleep mode is selected.

### J. System Override

1. This is useful in the event the remote batteries are low or the remote is misplaced.
2. **System Override - Cooling Operation**
  - a. Push the “Cool” button on the receiver.
  - b. System goes to the cooling mode with a set point of 74 °F.
3. **System Override - Heating Operation (if connected to furnace)**
  - a. Push the “Heat” button on the receiver.
  - b. System goes to the “heat” mode with a set point of 68 °F.

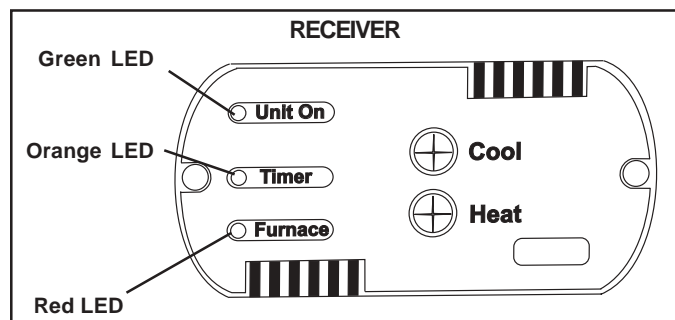

**Note:** If an electric heat strip is present, the control system will automatically choose this option even if a furnace is present. If the system does not have a heat strip then the furnace option will be chosen. The system can be turned “OFF” by pushing the same button (cool/heat) a second time.

### K. “I Feel” Operation

1. The cool, heat, furnace or auto change mode must be selected.

2. Set the temperature at the desired level, and push the “**I Feel**” button. The “**I FEEL**” symbol will appear on the display and a **beep** will sound indicating that the unit is in “**I FEEL**” mode.



3. The hand held remote becomes the temperature sensor and must be positioned to send updated signals to the receiver every two minutes.
4. The temperature can be adjusted to the desired level from the remote for its specific location.

**Note:** If the remote is placed in a location where the receiver cannot locate a signal for 16 minutes, the system will ignore the hand held remote and retain the last set-point.

**Note:** The remote should not be placed in an area that is warmer or colder than the rest of the living space (direct sunlight or air conditioner discharge drafts).

## L. Fahrenheit/Celsius Temporary Display

1. Locate the F°/C° Button under the door of the hand held remote. Push the button to display Fahrenheit (F°) temperature reading or press again to display Celsius (C°).

## M. Remote Reset

1. The “**Reset Button**” is located on the hand held remote under the door below the “**Set Button**”. Depress this button to delete all setting programmed into the control.

## N. Timer Operation

**Note:** Every time the **clock** or **timer** button is pressed, the display will blink for 15 seconds giving the operator enough time to change settings. If no changes are made in the 15 second time period the **timer** display will disappear.

**Note:** Any mode that uses the clock/timer function of the hand held remote will be disabled if the line of sight communication between the remote and receiver are **non existent** (putting the remote in a drawer).

1. Setting The Clock
  - a. When new batteries are installed, the clock will display 0:00.
  - b. Clock shows **only** military time.
  - c. Push the **clock** button , the clock display should blink.

- d. Press and hold the “**UP(+)**” or “**DOWN (-)**” button to set the clock.
- e. Press the “**SET**” button on hand held remote.

**Note:** When the set button is depressed be careful not to push the reset button at the same time. All previous setting will be lost and need to be re-entered.

2. Setting The Timer to “ON”
  - a. Press the “**timer**” button and the timer “**ON**” clock will appear and blink.
  - b. Set timer by pushing and holding the “**UP(+)**” or “**DOWN (-)**” buttons.
  - c. Point hand held remote at the receiver and press the “**SET**” button.
  - d. Receiver should **beep** and the **Orange** LED illuminate (if unit is off).

**Note:** When timer “**ON**” mode is activated the unit will turn “**ON**” in the last selected mode of operation, select the desired operation mode prior to setting timer . See TIMER OPERATION.

3. Setting The Timer to “OFF”
  - a. Press the “**timer**” button twice and the timer “**OFF**” clock will appear and blink.
  - b. Set timer by pushing and holding the “**UP(+)**” or “**DOWN (-)**” buttons.
  - c. Point hand held remote at the receiver and press the “**SET**” button.
  - d. Receiver should **beep** and the **Orange** LED illuminate (if unit is on).

**Note:** When timer “**Off**” mode is activated the unit will turn “**OFF**” when the clock & timer match. See TIMER OPERATION.

4. Setting The Timer to “ON” & “OFF”
  - a. Press the “**timer**” button three times and the timer “**ON**” clock will blink and “**OFF**” clock will be visible.
  - b. Set “**ON**” timer by pushing and holding the “**UP**” or “**DOWN**” buttons, then push the **timer** button again and the “**OFF**” will blink. Press and hold “**UP(+)**” or “**DOWN (-)**” to set “**OFF**” time.

**08:00**      **20:00**  
            **OFF**

- c. Point hand held remote at the receiver and press the “**SET**” button.
- d. Receiver should **beep** and the **Orange** LED illuminate (if unit is on).

**Note:** The **Orange** LED will light indicating the timer schedule is active. The unit will cycle on and off in the last mode selected. See TIMER OPERATION.

## WIRING DIAGRAM FOR MODELS 620615.321, 620615.326, 620625.321, 620625.326, 620626.321 & 620626.326

