



Installation Manual

For N61X models:
For N81X models:

6 cu.ft., 2-way, R.V. refrigerators.
8 cu.ft., 2-way, R.V. refrigerators.

The letter “X”, in the model numbers above, stands for a letter or numeral which means a refrigerator option.



WARNING: Improper installation, adjustment, alteration, service or maintenance can cause injury or property damage. Refer to this manual. For assistance or additional information, contact a qualified installer, service agency, or the gas supplier.

FOR YOUR SAFETY

Do not store or use gasoline or other flammable vapors and liquid in the vicinity of this or any other appliance.

FOR YOUR SAFETY

If you smell gas:

1. Open windows.
2. Don't touch electrical switches.
3. Extinguish any open flame.
4. Immediately call your gas supplier.



WARNING: DO NOT install this refrigerator in below deck marine applications. Do not install this refrigerator in fixed indoor cabin or other dwelling applications. This refrigerator must use only NORCOLD designed and approved outside air intake and exhaust ventilation for correct and safe operation. Any other ventilation could cause lethal combustion exhaust fumes and/or explosive propane gas fumes to be in the living area and/or to be below deck.

English

French

Table of Contents

Safety Awareness	2
Safety Instructions	2
Certification and Code Requirements	3
Ventilation Requirements	3
Key Refrigerator Dimensions	4
Assemble the Enclosure for the Refrigerator	4
Install the Lower and Upper Vents	4
Install Decorative Door Panels	6
Install the Refrigerator	6
Reverse the Door Swing-Nonmetal Doors (optional)	7
Reverse the Door Swing-Metal Doors (optional)	8
Connect the Electrical Components	9
Connect the 120 volts AC supply	9
Connect the 12 volts DC supply	9
Connect the Propane Gas Components	10
Connect the propane gas supply system	10
Examine the propane gas supply system for leaks	10
Ignition and Start Up	11
Ignition and start up	11
Do a test of the gas safety valve	11
Shut down - all models	11
Display Codes	12
Fault Codes	12

Safety Awareness

Read this manual carefully and understand the contents before you install the refrigerator.

Be aware of possible safety hazards when you see the safety alert symbol on the refrigerator and in this manual. A signal word follows the safety alert symbol and identifies the danger of the hazard. Carefully read the descriptions of these signal words to fully know their meanings. They are for your safety.



WARNING: This signal word means a hazard, which if ignored, can cause dangerous personal injury, death, or much property damage.



CAUTION: This signal word means a hazard, which if ignored, can cause small personal injury or much property damage.

Safety Instructions



WARNING:

- This refrigerator is not approved for use as a free standing refrigerator. It is equipped for the use of propane gas only and can not be changed to use any other fuels (natural gas, butane, etc.).
- Incorrect installation, adjustment, alteration, or maintenance of this refrigerator can cause personal injury, property damage, or both.
- Obey the instructions in this manual to install intake and exhaust vents.
- Do not install the refrigerator directly on carpet. Put the refrigerator on a metal or wood panel that extends the full width and depth of the refrigerator.
- Do not allow anything to touch the refrigerator cooling system.
- Propane gas can ignite and cause an explosion that can result in property damage, personal injury, or death. Do not smoke or create sparks. Do not use an open flame to examine the propane gas supply line for leaks. Always use two wrenches to tighten or loosen the propane gas supply line connections.
- Make sure the electrical installation obeys all applicable codes. See "Certification and Code Requirements" section.
- Do not bypass or change the refrigerator's electrical components or features.
- Do not spray liquids near electrical outlets, connections, or the refrigerator components. Many liquids are electrically conductive and can cause a shock hazard, electrical shorts, and in some cases fire.
- The refrigerator cooling system is under pressure. Do not try to repair or to recharge a defective cooling system.
- The cooling system contains sodium chromate. The breathing of certain chromium compounds can cause cancer. The cooling system contents can cause severe skin and eye burns, and can ignite and burn with an intense flame. Do not bend, drop, weld, move, drill, puncture, or hit the cooling system.



CAUTION:

- The rear of the refrigerator has sharp edges and corners. To prevent cuts or abrasions when working on the refrigerator, use caution and wear cut resistant gloves.

Certification and Code Requirements



Art01290



This refrigerator is certified by CSA International as meeting the latest edition of ANSI Z21.19 / CAN 1.4 standards for installation in mobile homes or recreational vehicles.

The installation must obey these standards and this "Installation Manual" for the NORCOLD limited warranty to be in effect. Installation must conform with the following as applicable:

In the United States and Canada:

- Local codes, or in the absence of local codes, the National Fuel Gas Code, ANSI Z223.1/NFPA 54, the Natural Gas and Propane installation Code, CSA B149.1, ANSI A119.2 Recreational Vehicles Code, and CSA Z240 RV Series, Recreational Vehicles.
- A manufactured home (mobile home) installation must conform with the Manufactured Home Construction and Safety Standard, Title 24 CFR, Part 3280 [formerly the Federal Standard for Mobile Home Construction and Safety, Title 24 (part 280), and the current CSA Z240.4, Gas-equipped Recreational Vehicles and Mobile Housing.
- If an external power source is utilized, the appliance, when installed, must be electrically grounded in accordance with local codes or, in the absence of local codes, the National Electrical code, and ANSI/NFPA 70, or the Canadian Electrical Code, CSA C22.2. Parts 1 and 2.

All propane gas supply piping and fittings must obey local, state, and national codes about type and size. These components must also obey the current NFPA 501C section 2-4, and in Canada with the current CAN 1-6.10 Standard.

Ventilation Requirements



WARNING: The completed installation must:

- Make sure there is sufficient intake of fresh air for combustion.
- Make sure the living space is completely isolated from the combustion system of the refrigerator.
- Make sure there is complete and unrestricted ventilation of the flue exhaust which, in gas mode, can produce carbon monoxide. The breathing of carbon monoxide fumes can cause dizziness, nausea, or in extreme cases, death.
- Make sure the refrigerator is completely isolated from its heat generating components through the correct use of baffles and panel construction.

Certified installation needs one lower intake vent and one upper exhaust vent. Install the vents exactly as written in this manual. Any other installation method voids both the certification and the factory warranty of the refrigerator.

The bottom of the opening for the lower intake vent, which is also the service access door, must be even with or immediately below the floor level. This allows any leaking propane gas to escape to the outside and not to collect at floor level.

CSA International certification allows the refrigerator to have zero (0) inch minimum clearance at the sides, rear, top, and bottom. While there are no maximum clearances specified for certification, the following maximum clearances are necessary for correct refrigerator performance:

Bottom	0 inch min.	0 inch max.
Each Side	0 inch min	1/2 inch max.
Top	0 inch min.	1/4 inch max.
Rear	0 inch min.	1 inch max.

These clearances plus the lower and upper vents cause the natural air draft that is necessary for good refrigeration. Cooler air comes in through the lower vent, goes up around the refrigerator coils where it removes the excess heat from the refrigerator components, and goes out through the upper vent. If this air flow is blocked or decreased, the refrigerator will not cool correctly.

Each NORCOLD model is certified by CSA International for correct ventilation. Install only the certified vents that are listed in this manual.

Key Refrigerator Dimensions

These key refrigerator dimensions are for your reference as necessary (See Art01733).

Refrigerator cabinet width w/o trim - 23.1 in.	1
Refrigerator width overall w/ trim - 24.6 in.	2
Refrigerator cabinet to side trim - 0.80 in.	3
Refrigerator cabinet height w/o trim	4
N600 models - 52.6 in.	
N800 models - 59.6 in.	
Refrigerator height overall w/ trim	5
N600 models - 54.5 in.	
N800 models - 61.5 in.	
Refrigerator cabinet to top/bottom trim - 0.93 in.	6
Enclosure wall to hinges - 1.10 in.	7
Refrigerator cabinet to center of handles	8
N600 models - 32.5 in.	
N800 models - 39.5 in.	

Assemble the Enclosure for the Refrigerator

1. Make sure the enclosure is 59.88 - 60.01 inches high for N81X models or 52.88 - 53.01 inches high for N61X models x 23.50 - 23.63 inches wide x 24 inches deep.
2. Make sure the floor is solid and level.
 - The floor must be metal or a wood panel and extend the full width and depth of the enclosure.
 - The floor must be able to support the weight of the refrigerator and its contents.
3. Make sure there are no adjacent heat sources such as a furnace vent, a hot water heater vent, etc.

Install the Lower and Upper Vents

1. Using the following chart, decide which vents and rough opening (RO) sizes to use:

Certified Vent	P/N	RO Height	RO Width
Upper Roof Exhaust Cap	622293	N/A	N/A
Upper Roof Exhaust Vent	616319	24 in.	5 1/4 in.

Lower Metal Intake	616010	13 5/8 in.	21 5/8 in.
Upper Exhaust & Lower Intake Plastic	621156	13 3/4 in.	21 1/2 in.

2. Install the lower intake vent (See Art01598, Art01599, and Art01602):

NOTE: The lower intake vent is also the service access opening for the components on the rear of the refrigerator.



WARNING: Make sure the bottom of the opening of the lower intake vent is even with or immediately below the floor level. This allows any leaking propane gas to escape to the outside and not to collect at floor level.

- Make sure the bottom of the opening of the lower intake vent [1] is even with or immediately below the floor level.
- Align the lower intake vent vertically below the coils [2] and the condenser [3] of the refrigerator.

3. Install the upper exhaust vent:



CAUTION: Make sure that no sawdust, insulation, or other construction debris is on the refrigerator or in the enclosure. Debris can cause a combustion hazard and prevent the refrigerator from operating correctly.

NOTE: Tighten the screws of the upper roof exhaust cap to 10 inch-pounds max. Also make sure that the air flow around the upper roof exhaust cap is not blocked or decreased by other roof mounted features such as a luggage carrier, an air conditioner, a solar panel, etc.

- If the design of the vehicle allows, install the roof exhaust vent [4] directly above the condenser [3] of the refrigerator (See Art01598).
 - Install a baffle [5] to prevent stagnant hot air in the area [6] above the refrigerator.
 - Make sure there is less than 1/4 inch clearance [7] between the baffle and the top of the refrigerator.
 - Make sure the baffle is the full width of the inside of the enclosure.
- If the design of the vehicle does not allow you to install the roof exhaust vent directly above the condenser [3] of the refrigerator (See Art01599).
 - Align the roof exhaust vent [4] above the condenser [3] of the refrigerator and move it inboard as necessary.

- Install two baffles [8] to prevent stagnant hot air in the area [6] above the refrigerator.
 - Make sure the baffles are the full width of the inside of the enclosure.
 - Make sure that the baffles are no more than 45° from vertical [9].
 - Put one baffle between the top rear edge of the refrigerator and the inside edge of the upper exhaust vent opening.
 - Put the other baffle between the outside edge of the upper exhaust vent opening and the side wall of the vehicle.
 - If the depth of the enclosure is 24 inches or more and is less than 25 inches, no baffles are necessary at the rear of the enclosure.
 - If the depth of the enclosure is 25 inches or more and is less than 26 inches, add two baffles [10] to the rear of the enclosure (See Art01598 and Art01599).
 - Put one baffle 18 inches to 18 1/2 inches above the bottom of the enclosure [26] (4 1/4 inches to 4 3/4 inches above the top of the lower intake vent opening REF) [27].
 - Put the other baffle at the lowest edge of the condenser [3] of the refrigerator.
 - Make sure that the baffles are 1 inch or less [28] from the coils [2] and condenser of the refrigerator.
 - Make sure that the baffles are the full width of the inside of the enclosure.
 - If the depth of the enclosure is more than 26 inches, install a wood or an aluminum or galvanized sheet solid box baffle [25] in the rear of the enclosure (See Art01617 and Art01618).
 - Make sure that the bottom of the solid box baffle is 18 inches to 18 1/2 inches above the bottom of the enclosure [26] (4 1/4 inches to 4 3/4 inches above the top of the lower intake vent opening REF) [27].
 - Make sure that the back of the solid box baffle is perpendicular to the bottom of the enclosure.
 - Make sure that the back of the solid box baffle is either against the top of the enclosure or against the angled baffle [8] (depending on the vehicle design).
 - Make sure that the solid box baffle is one inch or less [28] from the coils [2] and condenser of the refrigerator.
 - Make sure that the solid box baffle is the full width of the inside of the enclosure.
 - If there is more than 1/2 inch of clearance between either side of the refrigerator and the wall, fill the space with fiberglass insulation or add a baffle to eliminate the excess clearance.
 - If the design of the vehicle does not allow you to install a roof exhaust vent, install an upper side-wall exhaust vent.
- NOTE: The refrigerator is 23.7 in. min. to 24.0 in. max. from the rear of the breaker to the rear of the condenser [11]. N61X models are 48.7 in. min. to 49.0 in. max. from the bottom of the refrigerator to the bottom of the refrigerator condenser [12]. N81X models are 55.7 in. min. to 56.0 in. max. from the bottom of the refrigerator to the bottom of the refrigerator condenser [12] (See Art01601).
-  **CAUTION:** Only use an upper side-wall exhaust vent on refrigerator models that are equipped with a fan. If you use an upper side-wall exhaust vent on a refrigerator model that is not equipped with a fan, the refrigerator cooling performance will be poor.
- Make sure the refrigerator model is equipped with a fan.
 - Install the upper side-wall exhaust vent [13] (See Art01592 and Art01593).
 - For N61X models, make sure the distance [14] from the bottom of the enclosure to the top of the rough opening for the upper exhaust vent is at least 55 inches.
 - For N81X models, make sure the distance [14] from the bottom of the enclosure to the top of the rough opening for the upper exhaust vent is at least 62 inches.
 - Align the upper exhaust vent [13] horizontally above the lower intake vent [1] of the refrigerator.
 - To prevent stagnant hot air in the area above the refrigerator, install an aluminum or galvanized steel sheet baffle [15] between the top of the refrigerator and the top of the upper exhaust vent.
 - Make sure there is less than 1/4 inch clearance between the baffle and the top of the refrigerator and that the baffle overlaps the refrigerator 1 inch or less [16].
 - Make sure that the baffle is against the wall of the vehicle at the top of the upper exhaust vent and 1/4 inch or less from the top of the opening for the upper exhaust vent [17].

- Make sure the baffle is the full width of the inside of the enclosure

- Make sure the clearance at the sides of the refrigerator is correct:
 - If there is more than 1/2 inch of clearance between either side of the refrigerator and the wall, fill the space with fiberglass insulation or add a baffle to eliminate the excess clearance.
- When using an upper side-wall exhaust vent:
 - If the depth of the enclosure is more than 24 inches and less than 26 inches [18], install a bent aluminum or galvanized steel sheet baffle [19] to the rear of the enclosure (See Art01592).
 - Make sure that the bend of the baffle is the full width of the inside of the enclosure.
 - Make sure that the bend of the baffle is flush with the bottom edge of the upper intake vent door frame.
 - Make sure that the top edge of the baffle is 1/4 inch or less [20] below the condenser [3] and that there is 1/4 inch or less clearance [21] between the lower rear corner of the condenser and the baffle.
 - If the depth of the enclosure is more than 26 inches [22], install a wood or an aluminum or galvanized steel sheet solid box baffle [23] between the lower intake vent and the upper exhaust vent (See Art01593).
 - Make sure that the solid box baffle is the full width of the inside of the enclosure.
 - Make sure that the bottom of the solid box baffle is 18 inches to 18 1/2 inches above the bottom of the enclosure [26] (4 1/4 inches to 4 3/4 inches above the top of the lower intake vent opening REF) [27] .
 - Make sure that the back of the solid box baffle is perpendicular to the bottom of the enclosure.
 - Make sure that the horizontal top of the solid box baffle is even with the bottom edge of the upper exhaust vent [13].
 - Make sure that the vertical top edge of the baffle is 1/4 inch or less [20] below the lower rear corner of the condenser [3].
 - Make sure that there is 1/4 inch or less clearance [21] between the rear of the condenser and the baffle.

Install Decorative Door Panels

NOTE: The doors are made to accept decorative panels. The decorative panels must be 3/16 inch or less in thickness. Install the decorative door panels in the refrigerator doors before installing the refrigerator in the vehicle.

- Make an upper door panel that is 21 19/32 inches wide x 14 17/32 inches high.
- Make a lower door panel that is:
 - 21 19/32 inches wide and
 - 31 5/8 inches high (for N6XX models) or
 - 38 5/8 inches high (for N8XX models).
- Pull the panel retainer [1] off each door (See Art00965).
- Push the decorative door panel [2] into the slots of the door [3].
- Push each panel retainer into the slot on the edge of the door.

Install the Refrigerator

Put the refrigerator in position (See Art00962, Art00963, and Art00964):

-  **WARNING:** Make sure the combustion seal [11] is not broken, is completely around the refrigerator mounting flanges, and is between the mounting flanges and the wall of the enclosure. If the seal is not complete, exhaust fumes can be present in the living area of the vehicle. The breathing of exhaust fumes can cause dizziness, nausea, or in extreme cases, death.
- Push the refrigerator completely into the enclosure.
- Put the upper trim piece [13] onto the front of the refrigerator.
- Put screws [12] through the upper and lower mounting flanges on the front of the refrigerator and into the enclosure wall and floor.
- Put a cap [14] on each of the screw holes in the upper trim piece [13] on the front of the refrigerator.

-  **WARNING:** Do not omit the bottom trim piece. This piece is part of the combustion seal.

- Push the bottom trim piece [15] onto the front of the refrigerator.
- Put two screws [16] through the trim piece, the mounting flange, and into the floor.
- Put screws through mounting flange on the rear of the refrigerator and into the floor.

Reverse the Door Swing-Nonmetal Doors (optional)

This refrigerator has cabinet hinges that allow you to change the direction the door opens by moving the hinges on a diagonal to the opposite side.

1. Remove the doors (See Art01726):

- Remove the storage bins from the doors.

NOTE: Do not mix the upper and lower hinge pins because they are different.

- Remove and save the upper hinge pin [1] from each door.
- Pull the door latch and remove each door from the refrigerator.
- Remove and save the lower hinge pin [5] from each hinge.

2. Change the position of the cabinet hinges and the strike plate (See Art01728):

- Remove and save the screws from the strike plate [2a].
- Remove the two plastic hole caps that are near the strike plate.
- Remove the L-shaped plastic covers that are opposite the hinges.
- Remove and save the screws from the upper cabinet hinge [3a] of each door.
- Put each of these hinges on the other side of the refrigerator as the lower hinge [3b].
- Attach each of these hinges with screws.
- Remove and save the screws from the lower cabinet hinge [4a] of each door.
- Put each of these hinges on the other side of the refrigerator as the upper hinge [4b].
- Attach each of these hinges with screws.

- Put the L-shaped plastic covers over the holes that were used by the hinges.
- Remove and save the screw [7] from the front box [6] (See Art01573).

- Pull the front box away from the refrigerator and out from under the controls [8].
- Reverse the front box and put it on the opposite side of the controls.
- Attach the front box to the refrigerator with the screw.

- Put the strike plate on the opposite side of the refrigerator [2b].

- Put the two round plastic caps into the holes that are near the strike plate.

3. Change the position of the door handles (See Art01727):

- Remove the screws [12] and door handle [10] from each door.
- Reverse each door handle and put the lower door handle on the upper door and the upper door handle on the lower door.
- Attach each door handle with the screws.

4. Reinstall the doors (See Art01726):

- Turn the lower hinge pins into the lower cabinet hinges.

NOTE: To prevent damage to the threads of the hinge pins, turn the hinge pins by hand until tight and then tighten with a screwdriver.



CAUTION: Apply Loctite removable thread locker (blue) to the threads of the hinge screws before assembly to prevent loosening during use. Do not allow Loctite to contact any of the plastic surfaces of the refrigerator because it can damage those surfaces.

- Put each door down onto the lower hinge pin.
- Align the holes in the upper hinges and hold in this position.
- Turn the upper hinge pin into the hinges of each door.
- Tighten the hinge pins.
- Put the storage bins in the doors.

Reverse the Door Swing-Metal Doors (optional)

This refrigerator has door hinges that allow you to change the direction the door opens by moving the hinges on a diagonal to the opposite side.

1. Remove the doors (See Art00986):
 - Remove the storage bins from the doors.
 - Remove and save both hinge pins [1] from each door.
 - Pull the door latch and remove each door away from the refrigerator.
2. Change the position of the cabinet hinges and the strike plate (See Art01728):
 - Remove and save the screws from the strike plate [2a].
 - Remove the two plastic hole caps that are near the strike plate.
 - Remove the L-shaped plastic covers that are opposite the hinges.
 - Remove and save the screws from the upper cabinet hinge [3a] of each door.
 - Put each of these hinges on the other side of the refrigerator as the lower hinge [3b].
 - Attach each of these hinges with screws.
 - Remove and save the screws from the lower cabinet hinge [4a] of each door.
 - Put each of these hinges on the other side of the refrigerator as the upper hinge [4b].
 - Attach each of these hinges with screws.
 - Put the L-shaped plastic covers over the holes that were used by the hinges.
 - Remove and save the screw [7] from the front box [6] (See Art01573).
 - Pull the front box away from the refrigerator and out from under the controls [8].
 - Reverse the front box and put it on the opposite side of the controls.
 - Attach the front box to the refrigerator with the screw.
 - Put the strike plate on the opposite side of the refrigerator [2b].
3. Change the position of the door handles and the door hinges (See Art01695, Art00985, and Art00986):
 - Put the two round plastic caps into the holes that are near the strike plate.
 - Remove the plastic cap that is opposite the upper hinge of the upper door.
 - Remove the cap screws [9] from the door handle [10] and door hinge [11].
 - Remove the screws [12] and door handle from each door.
 - Remove the upper hinge of each door.
 - Put each of these hinges on the other side of the door as the lower hinge.
 - Attach each of these hinges with the cap screws that were removed from the other side.
 - The recommended torque for each cap screw [9] is 35 in.-lbs.
 - Remove the lower hinge of each door.
 - Put each of these hinges on the other side of the door as the upper hinge.
 - Attach each of these hinges with the cap screws that were removed from the other side.
 - Reverse each door handle and put the lower door handle on the upper door and the upper door handle on the lower door.
 - Attach each door handle with a cap screw [9] and screws [12].
 - Put the plastic cap into the hole that is opposite the upper hinge of the upper door.
4. Reinstall the doors (See Art00986):
 - Make sure each hinge bushing [13] is in the correct position.
 - Put each hinge bushing into the bottom side of each door hinge.
 - Put each door in the position on the refrigerator.

NOTE: To prevent damage to the threads of the hinge pins, turn the hinge pins by hand until tight and then tighten with a screwdriver.

 **CAUTION:** Apply Loctite removable thread locker (blue) to the threads of the hinge screws before assembly to prevent loosening during use. Do not allow Loctite to contact any of the plastic surfaces of the refrigerator because it can damage those surfaces.

- Align the hinges and put the hinge pins into each door.
- Tighten the hinge pins.
- Put the storage bins in the doors.

Connect the Electrical Components

AC Operation	120 volts AC voltage (132 volts max. - 108 volts min.)
	12 volts DC control voltage (15.4 volts max. - 10.5 volts min.)

This refrigerator operates on these electrical sources. Operation out of these limits may damage the refrigerator's electrical circuit parts and will void the warranty.

 **WARNING:** The rear of the refrigerator cooling system has hot surfaces and sharp surfaces that can damage electrical wiring. Make sure that there is a good clearance between all electrical wiring and the cooling system of the refrigerator. Position any electrical wiring within the refrigerator enclosure opposite the burner side of the refrigerator. Do not put any electrical wiring through the roof exhaust vent. Failure to correctly position electrical wiring can result in electrical shock or fire.

Connect the 120 volts AC supply:

 **WARNING:** Connect the AC power cord(s) only to a grounded three-prong receptacle. Do not remove the round ground prong from any of the AC power cords. Do not use a two prong adapter or an extension cord with any of the AC power cords. Operation of the refrigerator without correct ground can cause dangerous electrical shock or death if you are touching the metal parts of the refrigerator.

Put the AC power cord(s) into a grounded three-prong receptacle:

- Make sure the receptacle is positioned within easy reach of the lower intake vent.
- Make sure the power cord(s) does not touch the burner cover, the flue pipe, or any hot component that could damage the insulation of the power cord.

Connect the 12 volts DC supply:

As the distance from the vehicle battery to the refrigerator increases, the correct AWG wire size and fuse size also increases. If the wire size is too small for the distance, a voltage drop occurs.

1. Determine the min. wire size and the max. fuse size to use:

 **WARNING:** If you use an incorrect wire size and/or fuse size, electrical fire can result.

- Use a minimum of 18 AWG wire and a maximum 6 Amp fuse.
 - If the wire size is larger than the min. size, use the correct fuse per RVIA A119.2 standard or local codes.
2. Install a fuse in DC power supply wires between the battery and the refrigerator:
- Put fuse as close to the battery as possible.
3. Connect the DC power supply wires (See Art00966):

- Attach a 1/4 inch Quick Connect terminal to each DC power supply wire.

NOTE: Do not use the chassis of the refrigerator or the vehicle frame as one of the conductors. Attach the DC power supply wires only to the battery and the power board [1] of the refrigerator.

- Push the positive DC power wire [2] onto the power board terminal that is marked 12VDC.
- Push the DC ground wire [3] onto the power board terminal that is marked 12V GND1.
- Make sure each DC power supply wire is on the correct polarity terminal.

Connect the Propane Gas Components

This refrigerator operates on propane gas at a pressure of 11 inches Water Column Propane.

The controls operate on 12 volts DC (10.5 volts min. - 15.4 volts max.). Operation out of these limits can damage the refrigerator electrical circuit parts and will void the warranty

Connect the propane gas supply system:

WARNING: Be very careful when working on or near the propane gas system.

- Do not smoke, or use an open flame near the propane gas system.
- Do not use an open flame to examine for leaks.
- Do not connect the refrigerator to the propane gas tank without a pressure regulator between them.
- To avoid a propane gas leak, always use two wrenches to tighten or loosen the propane gas supply line connections.
- Leaking propane gas can ignite or explode and result in dangerous personal injury or death.

Connect the gas supply line to the refrigerator:

- Make sure that all tubing and fittings obey all local, state, and national codes about size and type.
- Make sure that all flexible metal connectors obey the current CAN1-6.10 Standard.
- Make sure that the materials used for the gas supply line obey both the current ANSI A 119.2 (NFPA 1192) and CSA Z240 Standards on Recreational Vehicles. Norcold recommends the use of 3/8 inch copper tubing as the gas supply line and requires a 3/8 inch SAE (UNF 5/8-18) male flare fitting as the connection to the refrigerator.
- Put the propane gas supply line up through the floor of the enclosure.
- Make sure the hole through the floor is large enough allow clearance for the gas supply line.
- Put a weather resistant seal (grommet, sealant, etc.) around the gas supply line where it goes through the floor to prevent vibration and abrasion.
- To prevent vibration and abrasion, make sure that the gas supply line is not against anything in the enclosure.
- Attach the gas supply line to the bulkhead fitting of the refrigerator.

Examine the gas supply system for leaks:

WARNING: Do not allow the leak detecting solution to touch the electrical components. Many liquids are electrically conductive and can cause electrical shorts and in some cases, fire.

Use a leak detecting solution to examine the gas supply line and all propane gas connections for leaks.

If you use compressed air for the test:

- The pressure of the compressed air at the manual shut off valve of the refrigerator must not be more than 1/2 psig (14 inches Water Column).
- If the pressure of the compressed air is more than 1/2 psig (14 inches Water Column), remove the gas supply line from the bulkhead fitting of the refrigerator before the test.
- If the pressure of the compressed air is equal to or less than 1/2 psig (14 inches Water Column), close the manual shut off valve of the refrigerator before the test.

Ignition and Start Up

Before ignition or start up of the refrigerator:

- Make sure the air flow in the lower intake vent, through the refrigerator coils and condenser, and out the upper exhaust vent is not blocked or decreased.
- Make sure there are no combustible materials in or around the refrigerator.

Refer to the "Display Codes" section of this manual.

Ignition and start up:

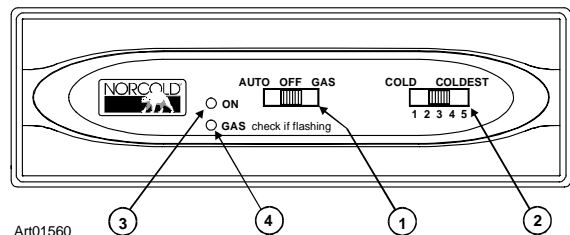

NOTE: If the gas does not ignite in 30 seconds, the gas safety valve of the refrigerator automatically closes and the GAS light flashes. To reset the controls, push the selector switch to the OFF position.

If the gas does not ignite after several attempts, refer to the "Fault Codes" section of this manual.

Automatic Mode Operation:

1. Push the selector switch [1] to the AUTO position (See Art01560).
2. Push the temperature switch [2] to the desired temperature setting.
 - If the ON light [3] only comes on, it means that:
 - 120 volt AC power is available to the refrigerator.
 - The refrigerator is operating on AC electric power.
 - If the ON light and the GAS light [4] both come on, it means that:
 - 120 volt AC power is not available to the refrigerator.
 - The refrigerator is operating on propane gas.

GAS Mode Operation:

1. Push the selector switch [1] to the GAS position.
2. Push the temperature switch [2] to the desired temperature setting.
 - If the ON light and the GAS light [4] both come on, it means that the refrigerator is operating on propane gas.

Do a test of the gas safety valve:

1. Start up the refrigerator in gas mode operation.
2. Open the lower intake vent.
3. Remove one wire from the solenoid of the gas safety valve at the rear of the refrigerator.
4. Within 30 seconds, the flame should extinguish. This means that the gas safety valve is operating correctly.
5. Put the wire back on the solenoid of the gas safety valve.
6. Close the lower intake vent.

Shut down:

To shut down the refrigerator, push the selector switch to the OFF position.

Display Codes

Light and Status	Meaning
ON light is on. GAS light is off.	The refrigerator is operating on AC.
ON light is on. GAS light is on.	The refrigerator is operating on propane gas.

Art01852

Fault Codes

Light and Status	Meaning	Corrective Actions
ON light is off	DC voltage is unavailable to the refrigerator control panel or the refrigerator is OFF.	<p>Check:</p> <ul style="list-style-type: none"> - That the refrigerator is ON. - That the battery charging equipment of the vehicle is operational. - That the AC/DC converter is operational (if applicable). - That the DC connection to the refrigerator is not loose. - That the DC fuse of the refrigerator is intact. - See your dealer or authorized Norcold Service Center.
ON light and GAS light both flash about once per second.	No energy source is available. AC voltage is not available (or the refrigerator is in Manual GAS mode), and the burner did not ignite or re-ignite.	<p>If in AUTO mode, check:</p> <ul style="list-style-type: none"> - That the refrigerator is plugged in. - That the fuse or circuit breaker of the vehicle is intact. - That the vehicle generator is operational (if applicable). - That the AC fuse of the refrigerator is intact. <p>In any mode, check:</p> <ul style="list-style-type: none"> - That the DC voltage is correct. - That the propane gas supply line is purged. - That the valve of the propane gas tank(s) is open. - That the propane gas is at the correct pressure. - That the manual shut off valve of the refrigerator is open. - Reset the refrigerator by turning it OFF and then back to AUTO or GAS mode. - See your dealer or authorized Norcold Service Center.
ON light is on. GAS light flashes about once per second.	The burner did not ignite or re-ignite. The refrigerator is in "gas lock-out", but AC voltage has returned and the refrigerator is operating on AC.	<p>Check:</p> <ul style="list-style-type: none"> - That the DC voltage is correct. - That the propane gas supply line is purged. - That the valve of the propane gas tank(s) is open. - That the propane gas is at the correct pressure. - That the manual shut off valve of the refrigerator is open. - Reset the refrigerator by turning it OFF and then back to AUTO or GAS mode. - See your dealer or authorized Norcold Service Center.
ON light is on , but flashes off 1 time about every 3 seconds.	The temperature sensor failed. The refrigerator is operating on the "Back-Up Operating System".	This is not owner servicable. See your dealer or authorized Norcold Service Center.
ON light is on , but flashes off 2 times about every 3 seconds.	The mode switch failed. The refrigerator is operating in the last known mode.	This is not owner servicable. See your dealer or authorized Norcold Service Center
ON light is on , but flashes off 3 times about every 3 seconds. GAS light is on.	The AC heater failed. The refrigerator will operate on propane gas only.	This is not owner servicable. See your dealer or authorized Norcold Service Center
ON light is on, but flashes off 4 times about every 3 seconds.	This is a fault within the refrigerator controls.	This is not owner servicable. See your dealer or authorized Norcold Service Center.

Art01583

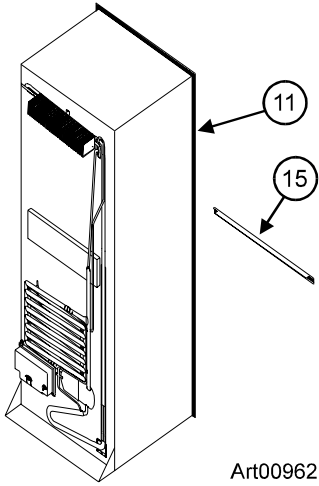

Art00962

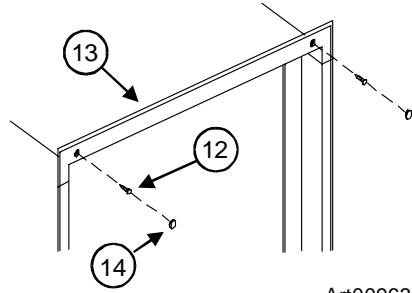

Art00963

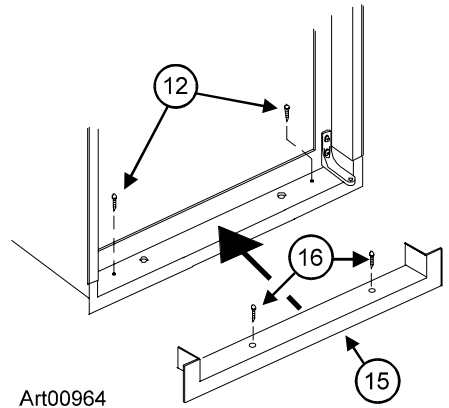

Art00964

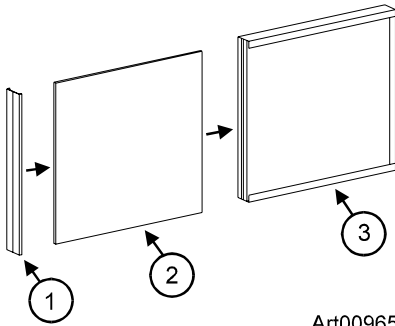

Art00965

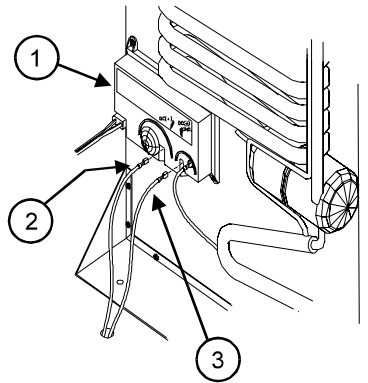

Art00966

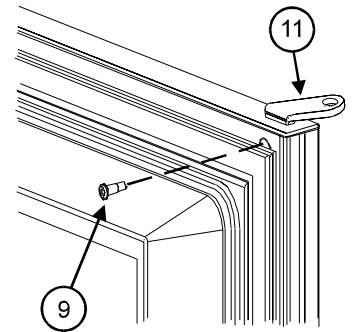

Art00985

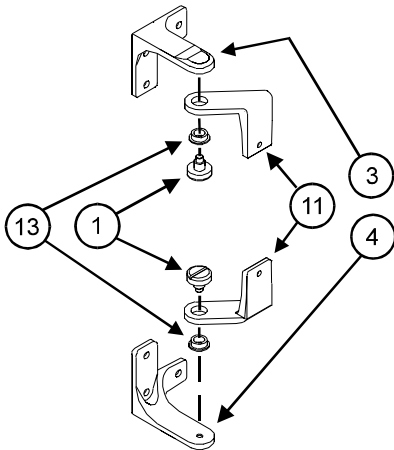

Art00986

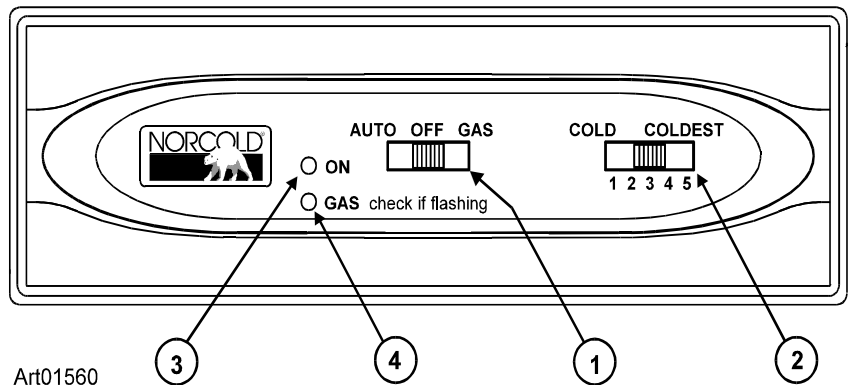

Art01560

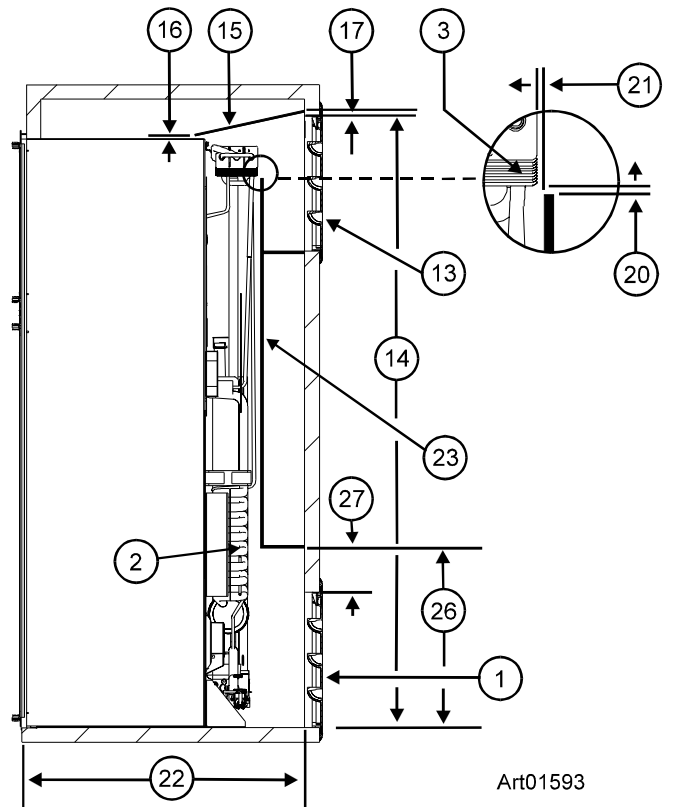
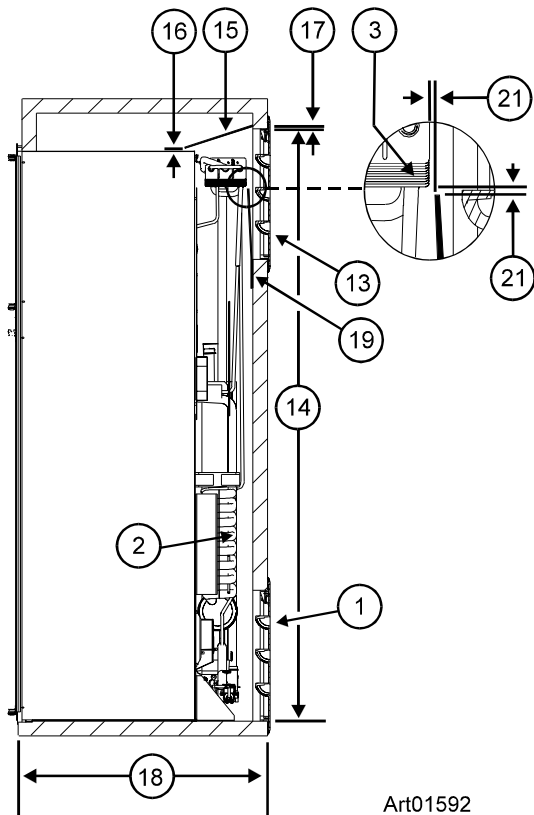
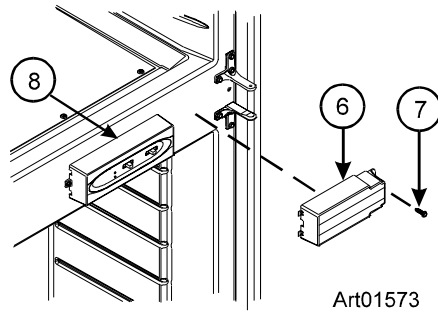

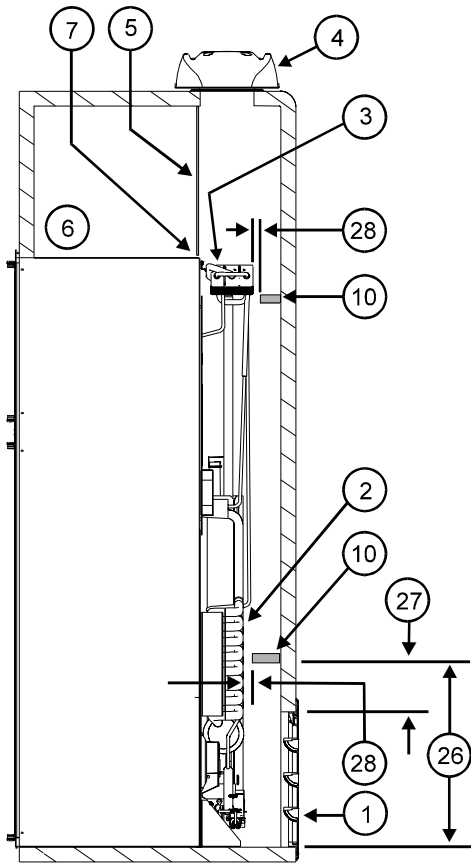

Art01598

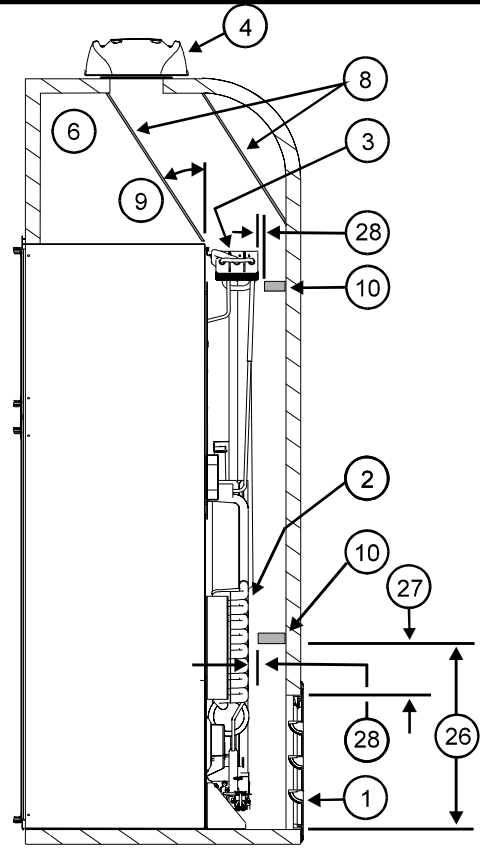

Art01599

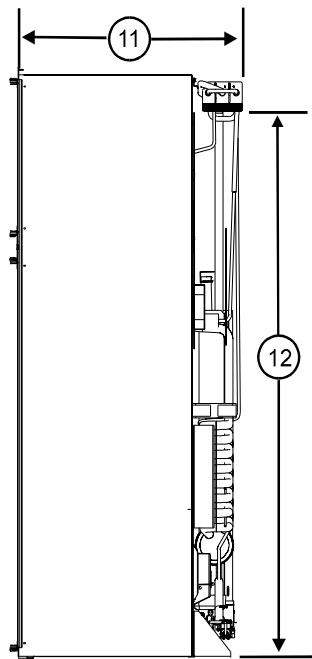

Art01601

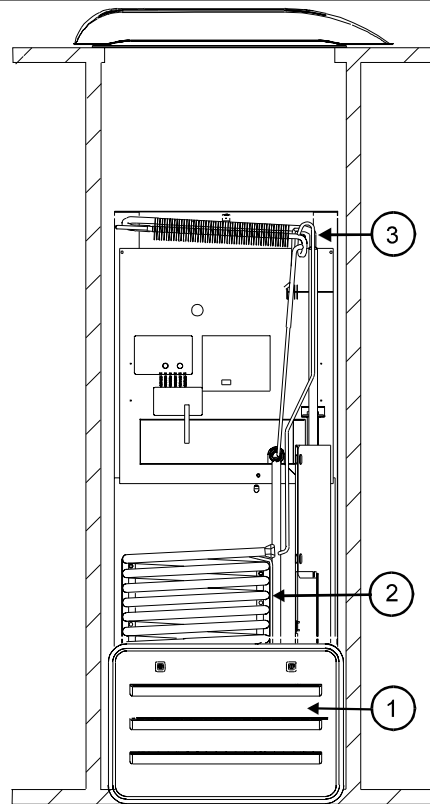

Art01602

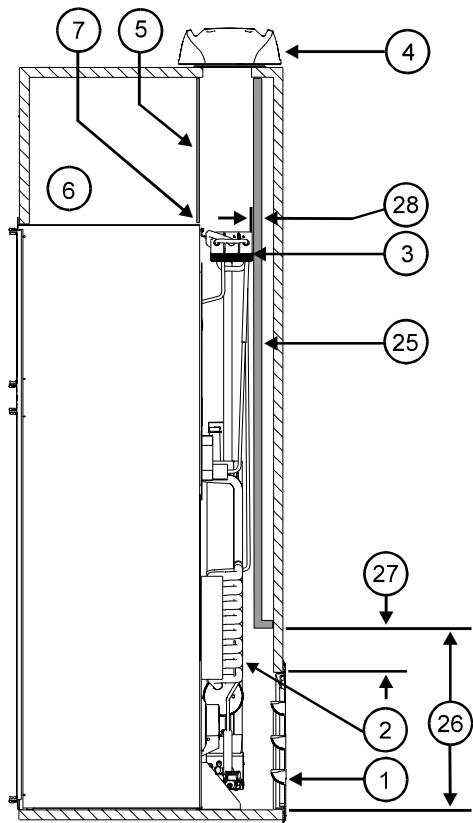

Art01617

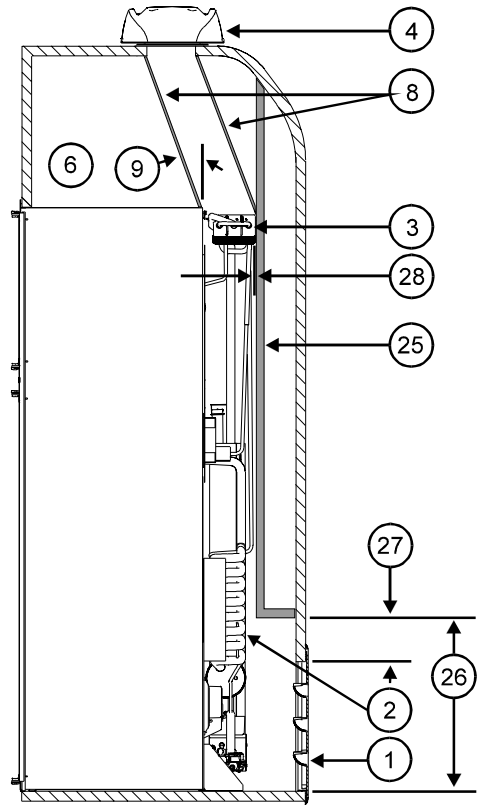

Art01618

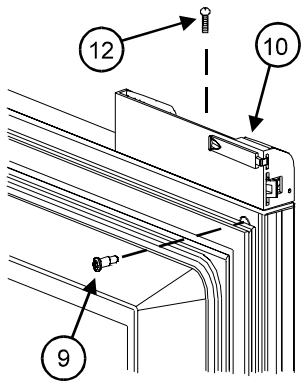

Art01695

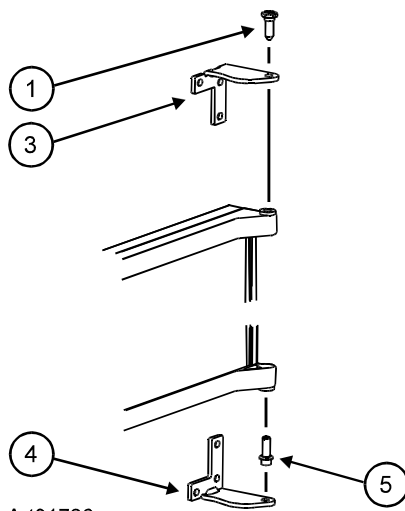

Art01726

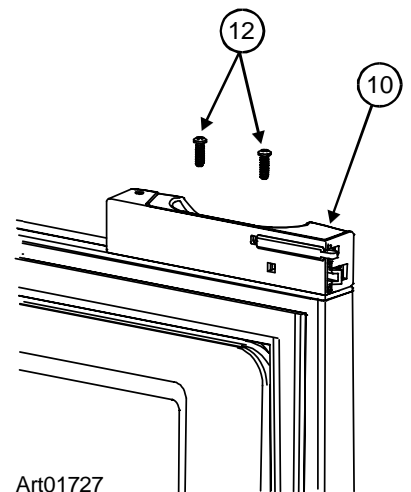

Art01727

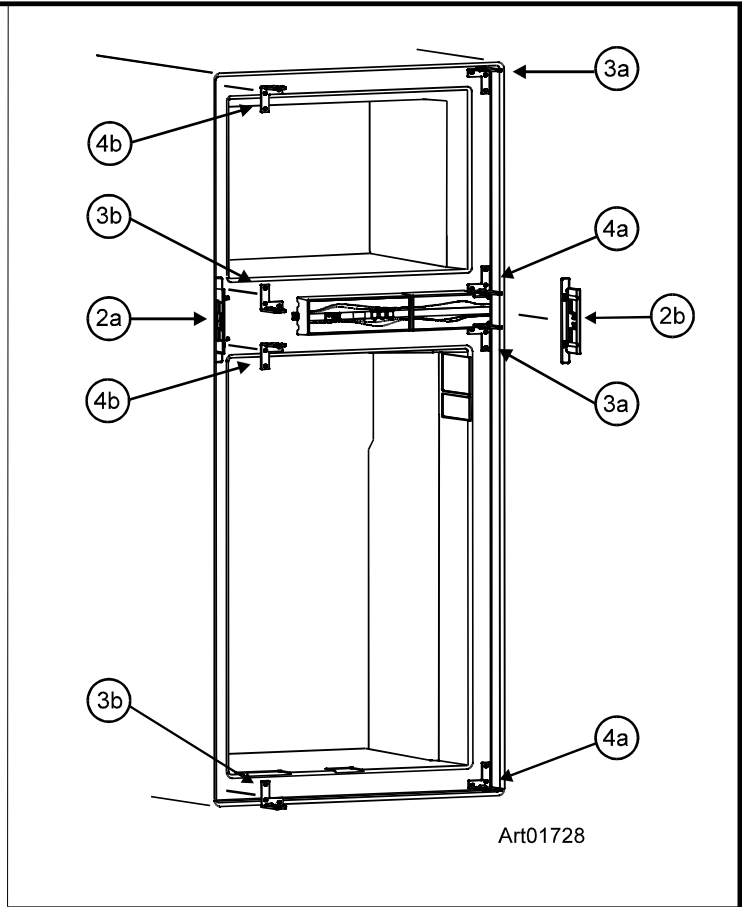
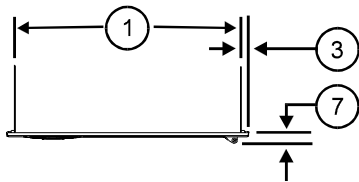

Art01728

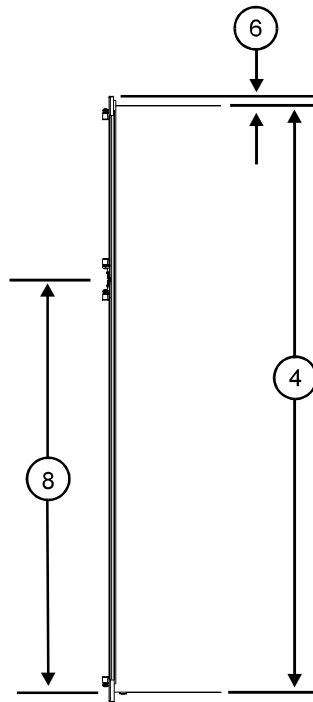
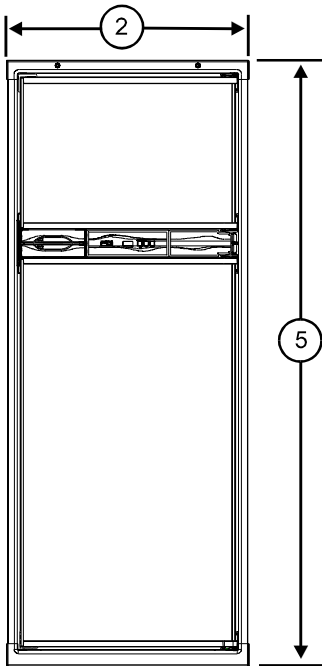

Art01733