

GENERAC® Air-cooled Recreational Vehicle Generator

OWNER'S MANUAL

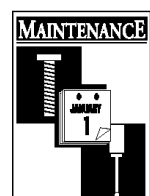
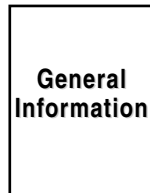
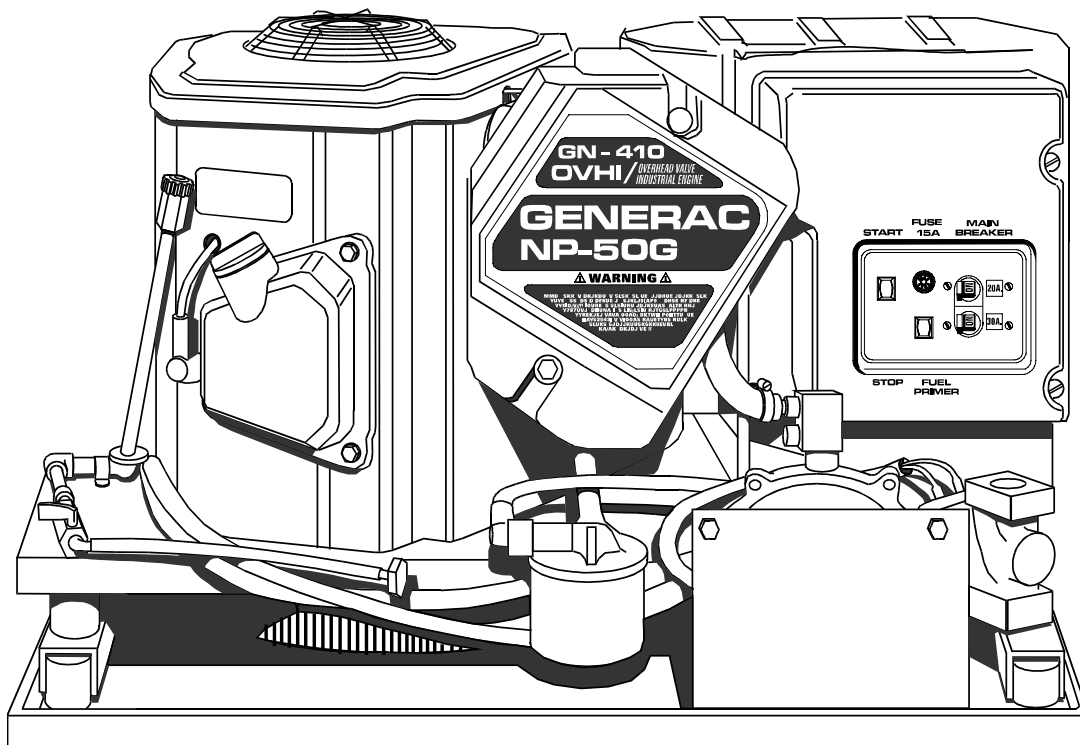

GENERAC® CORPORATION

Model No. 00919-0 Series NP-50LPG



THIS SYMBOL POINTS OUT IMPORTANT SAFETY INSTRUCTIONS, WHICH, IF NOT FOLLOWED, COULD ENDANGER THE PERSONAL SAFETY AND/OR PROPERTY OF YOURSELF AND OTHERS. READ AND FOLLOW ALL INSTRUCTIONS IN THE MANUAL BEFORE ATTEMPTING TO OPERATE THIS UNIT.

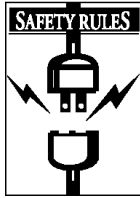

THE MANUFACTURER SUGGESTS THAT THESE “RULES” FOR SAFE OPERATION BE COPIED AND POSTED IN POTENTIAL HAZARD AREAS OF THE RECREATIONAL VEHICLE. SAFETY SHOULD BE STRESSED TO ALL OPERATORS AND POTENTIAL OPERATORS OF THIS EQUIPMENT.



WARNING:



The engine exhaust from this product contains chemicals known to the State of California to cause cancer, birth defects, or other reproductive harm.

Study these SAFETY RULES carefully before installing, operating or servicing this equipment. Become familiar with the Owner's Manual and with the generator. The generator can operate safely, efficiently and reliably only if it is properly installed, operated and maintained. Many accidents are caused by failing to follow simple and fundamental rules or precautions.

Generac cannot possibly anticipate every possible circumstance that might involve a hazard. The warnings in this Manual and on tags and decals affixed to the unit, are therefore, not all-inclusive. If you use a procedure, work method or operating technique Generac does not specifically recommend, you must satisfy yourself that it is safe for you and others. You must also make sure the procedure, work method or operating technique that you choose does not render the generator to be unsafe.

- For fire safety, the auxiliary generator must be installed and maintained properly. Installation must always comply with applicable codes, standards, laws and regulations. Adhere strictly to local, state and national electrical and building codes. Comply with regulations the Occupational Safety and Health Administration (OSHA) established. Also, the generator and related components must be installed completely in conformance with the manufacturer's instructions and recommendations. Following proper installation, do nothing that might alter a safe installation and render the unit in non-compliance with such codes, standards, laws and regulations.

- ▲ The Recreational Vehicle Generator produces extremely high and dangerous electrical voltages and can cause dangerous, and possibly fatal, electrical shock. Avoid contact with bare wires, terminals, etc. while the unit is running. If you must work around an operating generator, stand on an insulated, dry surface to reduce shock hazard.

- ▲ Never work on this equipment or handle any electrical device while standing in water, while barefoot, or while hands or feet are wet. Dangerous electrical shock will result.

- Have the generator properly grounded (bonded) during installation onto the vehicle, either by solid mounting to the vehicle frame or chassis or by means of an approved bonding conductor. DO NOT disconnect the bonding conductor, if so equipped. DO NOT reconnect the bonding conductor to any generator part that might be removed or disassembled during routine maintenance. If the grounding conductor must be replaced, use only a flexible conductor that is of No. 8 AWG copper wire minimum.

- Keep hands, feet, clothing, etc., away from drive belts, fans and other moving parts of this equipment. Never remove any drive belt or fan guards while the unit is operating.

- Inspect the generator periodically. Repair or replace all damaged or defective parts immediately.

- ▲ In case of accident caused by electric shock, shut down the source of electrical power at once. If this cannot be done, free victim from live conductor. AVOID DIRECT CONTACT WITH THE VICTIM. Use a dry board, dry rope, or other non-conducting implement to free the victim from live conductor. If victim is unconscious, apply first aid and get medical help

- Inspect fuel system frequently for leaks or damage. Repair or replace any damaged or leaking component immediately. Never attempt to change, alter or modify the generator fuel system in any way that might affect safety or compliance with applicable codes and standards.

- ▲ The generator engine gives off DEADLY carbon monoxide gas through its exhaust system. This dangerous gas, if breathed in sufficient concentrations, can cause unconsciousness or even death. This exhaust system must have been properly installed, in strict compliance with applicable codes and standards. Following installation, you must do nothing that might render the system unsafe or in non-compliance with such codes and standards. The generator compartment must be completely vapor sealed from vehicle interior. There must be no possibility of exhaust fumes entering the vehicle interior. Never operate this equipment with a leaking or defective exhaust system.

- Never use the generator or any of its parts as a step. Stepping on the unit can stress and break parts and may result in dangerous operating conditions from leaking exhaust gases, fuel leakage, oil leakage, etc.

- Do not smoke around the generator. Wipe up any fuel or oil spills immediately. Never leave oily or fuel soaked rags in the generator compartment or on the generator itself. Keep the area around the generator clean and free of debris.

- Adequate ventilation is required to expel toxic fumes and fuel vapors from the generator compartment. Do not alter the installation of this equipment in any manner that might obstruct air and ventilation openings. Such openings must be kept clear and unobstructed.

- ▲ Some generators may use LP gas (propane) as a fuel. LP gas is highly EXPLOSIVE. The gas is heavier than air and tends to settle in low areas where even the slightest spark can ignite the gas and cause an explosion.

- Before performing any maintenance on the generator set, disconnect its battery cables to prevent accidental start up. Disconnect the cable from the battery post indicated by a NEGATIVE, NEG or (-) first. Reconnect that cable last.



IDENTIFICATION RECORD

Generac NP-50LPG Recreational Vehicle Generator

Please record the following information from the generator DATA DECAL or information decal.

1. Model Number _____ 2. Serial Number _____

3. kW Rating _____ 4. Rated Voltage _____

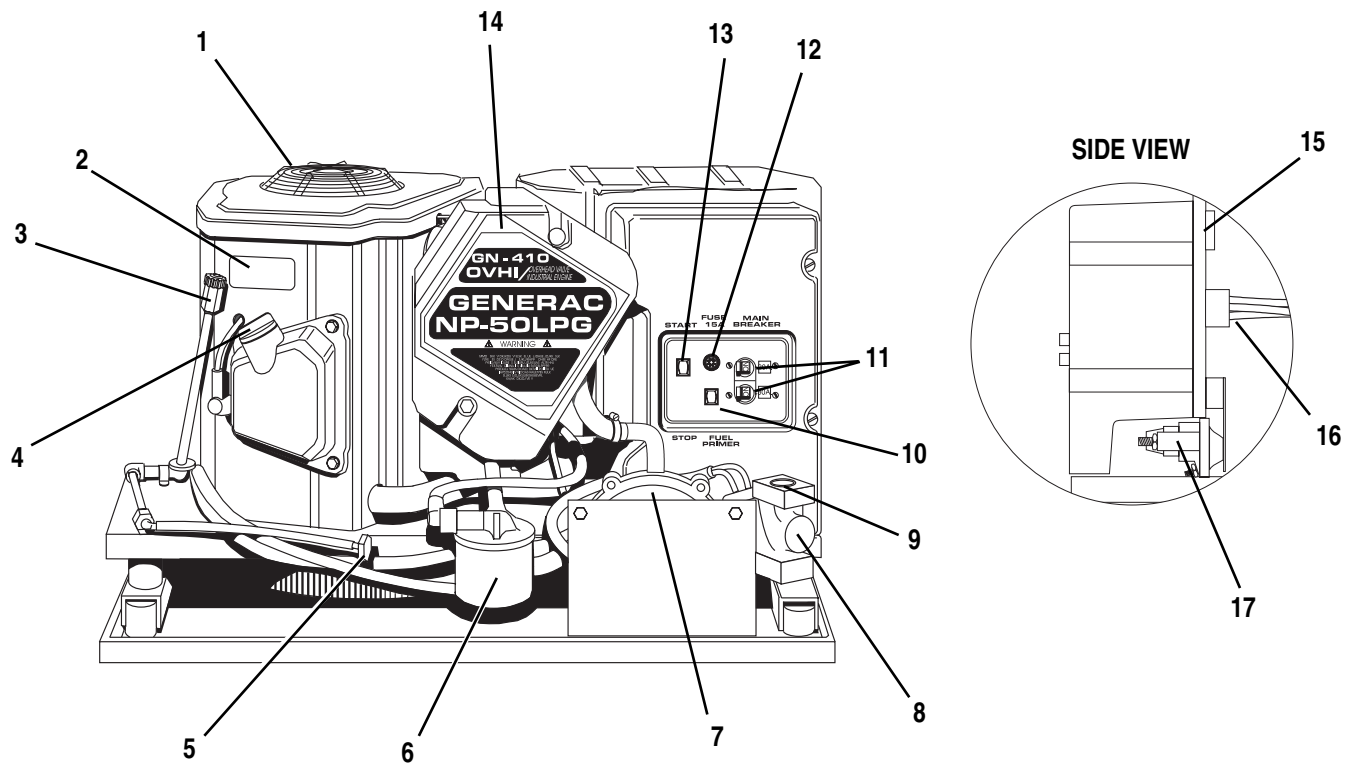

REFERENCE NUMBER IDENTIFICATION

- | | |
|--------------------------------|--------------------------------------|
| 1. Generator Air Intake Screen | 10. Fuel Primer Switch |
| 2. Data Decal | 11. Circuit Breakers |
| 3. Oil Dipstick | 12. Fuse |
| 4. Oil Filler Cap | 13. Engine Start/Stop Switch |
| 5. Oil Drain Plug | 14. Air Cleaner |
| 6. Oil Filter | 15. Optional Remote Panel Receptacle |
| 7. Fuel Regulator | 16. Generator AC Output Leads |
| 8. Fuel Solenoid | 17. Starter Contactor |
| 9. Fuel Inlet | |



**TABLE
OF
CONTENTS**

SAFETY RULES.....	2	MAINTENANCE	13-16
IDENTIFICATION RECORD.....	3	Checking Engine Oil Level	13
GENERAL FEATURES	3	Change Engine Oil	13
READ THIS MANUAL THOROUGHLY	5	Change Oil Filter	13
Operation and Maintenance.....	5	Engine Air Cleaner	14
How to Obtain Service	5	Clean Air Intake Screen	14
GENERATOR FAMILIARIZATION	6	Engine Spark Plug	14
Generator Applicability	6	Spark Arrestor Muffler	15
Installation	6	Cleaning the Generator	15
Safety	6	Battery	15
Generator AC Connection System.....	6	Major Service Manual	16
OPERATION	7-11	Drive Belts	16
Generator Control Panel	7	Exercising the Generator	16
Optional Remote Start/Stop Panel.....	7	Out of Service Protection.....	16
Before Starting the Engine	8	Return the Unit to Service after Storage	16
Starting the Generator	8-9	TROUBLESHOOTING	17
Stopping the Generator	9	REPAIR PARTS.....	20-29
Applying Loads to Generator	9-10	ELECTRICAL DATA	18-19
Additional Information	10-11	EMISSIONS WARRANTY	30-31
SPECIFICATIONS	12	BASIC 3-YEAR WARRANTY	back cover
Fuel Requirements.....	12		
Engine Oil Requirements	12		
Engine Specifications.....	12		
Generator Specifications	12		

READ THIS MANUAL THOROUGHLY

If you don't understand any portion of this manual, contact Generac for a demonstration of actual starting, operating and servicing procedures.

Throughout this publication and on tags and decals affixed to the generator, DANGER and CAUTION blocks are used to alert you to special instructions about a particular operation that may be hazardous if performed incorrectly or carelessly. Observe them carefully.

These safety warnings cannot eliminate the hazards that they indicate. Strict compliance with the special instructions while performing the service plus "common sense" are major measures to prevent accidents.

The following definitions apply to DANGER, WARNING, CAUTION and NOTE blocks found throughout the manual.



DANGER: AFTER THIS HEADING YOU CAN READ HANDLING, INSTALLING, OPERATING OR SERVICING INSTRUCTIONS THAT, IF NOT COMPLIED WITH, WILL RESULT IN PERSONAL INJURY.



WARNING: AFTER THIS HEADING YOU CAN READ HANDLING, INSTALLING, OPERATING OR SERVICING INSTRUCTIONS THAT, IF NOT COMPLIED WITH, MAY RESULT IN PERSONAL INJURY.



CAUTION: After this heading you can read instructions for handling, installing, operating or servicing the generator that, if not strictly complied with, may result in damage to equipment and/or property.

NOTE: After this heading you can read explanatory statements that require special emphasis.

These symbols indicate the following:



Points out important safety information and, if not followed, could endanger personal safety and/or property of yourself and others.



Potential explosion hazard.



Potential fire hazard.



Potential electrical shock hazard.

The operator (owner) is responsible for proper and safe use of the vehicle, equipment on the vehicle, and the safety of all vehicle occupants. We strongly recommend that the operator read this Owner's Manual and thoroughly understand all instructions before using this equipment. We also strongly recommend instructing other occupants in the vehicle to properly start and operate the generator. This prepares them if they need to operate the equipment in an emergency.

OPERATION AND MAINTENANCE

It is the operator's responsibility to perform all safety checks; to make sure that all maintenance for safe operation is performed promptly; and to have the equipment checked by an Authorized Dealer periodically. Normal maintenance service and replacement of parts are the responsibility of the Owner/Operator and, as such, are not considered defects in materials or workmanship within the terms of the warranty. Individual operating habits and usage contribute to the need for maintenance service.

Proper maintenance and care of your recreational vehicle generator assures a minimum number of problems and keeps your operating expenses at a minimum. See your authorized Dealer/Distributor for service aids and accessories.

HOW TO OBTAIN SERVICE

When your recreational vehicle generator set requires servicing or repairs, simply contact an Authorized Service Facility for assistance. Service technicians are factory-trained and are capable of handling all of your service needs.

When contacting an Authorized Service Facility or the factory about parts and service, always supply the complete model number and serial number of your unit as given on its data decal.

The warranty on your generator is included in the Owner's Manual, as well as listings for repair parts.

SERVICE DEALER LOCATION

TO LOCATE THE NEAREST GENERAC SERVICING DEALER, PLEASE CALL OUR 800 NUMBER.

ONLY DEALER LOCATION INFORMATION CAN BE OBTAINED AT THIS NUMBER.

1-800-333-1322



GENERAL INFORMATION

GENERATOR APPLICABILITY

These generators have been designed and manufactured for supplying electrical power for recreational vehicles. You should not modify the generator or use it for any application other than for what it was designed. If there are any questions pertaining to its application, write or call the factory. Do not use the unit until you have been advised by a competent authority.



DANGER: FOR FIRE SAFETY, THE GENERATOR MUST HAVE BEEN PROPERLY INSTALLED IN COMPLIANCE WITH (1) ANSI 119.2-1975/NFPA 501C-1974 "STANDARD FOR RECREATIONAL VEHICLES, PART III, "INSTALLATION OF ELECTRICAL SYSTEMS." THE GENERATOR ALSO MUST HAVE BEEN INSTALLED IN STRICT COMPLIANCE WITH THE MANUFACTURER'S DETAILED INSTALLATION INSTRUCTIONS. AFTER INSTALLATION, DO NOTHING THAT MIGHT RENDER THE UNIT IN NON-COMPLIANCE WITH SUCH CODES, STANDARDS AND INSTRUCTIONS.

You can use this generator to supply electrical power for operating 120/240 volts, single phase, 60 Hertz, AC electrical loads. These loads can require up to 4500 watts of (4.5kW) of power, but cannot exceed 37.5 AC amperes of current at 120 volts or exceed 18.8 AC amperes at 240 volts.



CAUTION: Do not overload the generator. Some installations may require that electrical loads be alternated to avoid overloading. Applying excessively high electrical loads may damage the generator and may shorten its life. Add up the rated watts of all electrical lighting, appliance, tool and motor loads the generator will power at one time. This total should not be greater than the wattage capacity of the generator. If an electrical device nameplate gives only volts and amps, multiply volts times amps to obtain watts (volts x amps = watts). Some electric motors require more watts of power (or amps of current) for starting than for continuous operation.

INSTALLATION

This Owner's Manual has been prepared under the assumption that a competent, qualified technician installed the generator. We also assume the installer complied with all applicable codes, standards and regulations pertaining to installation.

Owners/Operators must make sure to do nothing that might render the installation unsafe or in noncompliance with applicable codes, standards and instructions. They should be sure the unit has been installed to allow adequate ventilation for cooling and exhaust air.

SAFETY

Before attempting to use the generator set, carefully read GENERAL SAFETY RULES inside the cover of this Manual. Comply strictly with these RULES to prevent accidents and damage to equipment and/or property. We suggest that copying and posting GENERAL SAFETY RULES in potential hazard areas of the vehicle. Stress safety to all operators and potential operators of this equipment.

GENERATOR AC CONNECTION SYSTEM

This generator set is equipped with dual stator AC power windings. These two stator windings supply electrical power to customer electrical loads by means of a dual 2-wire connection system. Note, however, that neutral is grounded.

The generator may have been installed so that the unit powers 120 volt AC loads (Figure 1); or you can wire them to connect both 120 and/or 240 volt AC electrical loads. Be sure to install jumper wire between the circuit breakers when reconnecting for 120/240 volts. Refer to the Installation Manual for more information.

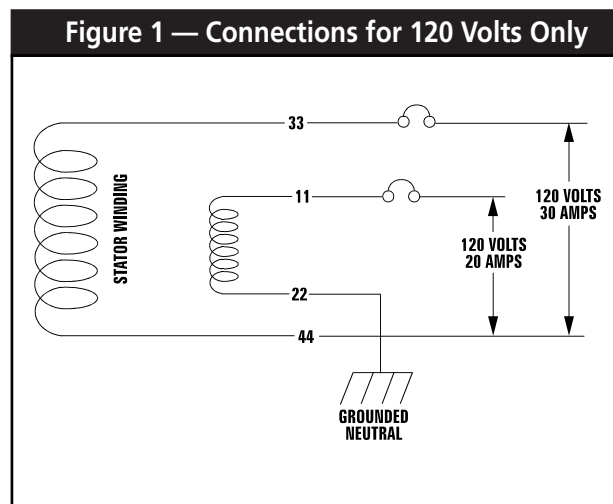



GENERATOR CONTROL PANEL

Mounted on the generator control panel (Figure 2) are the following features:

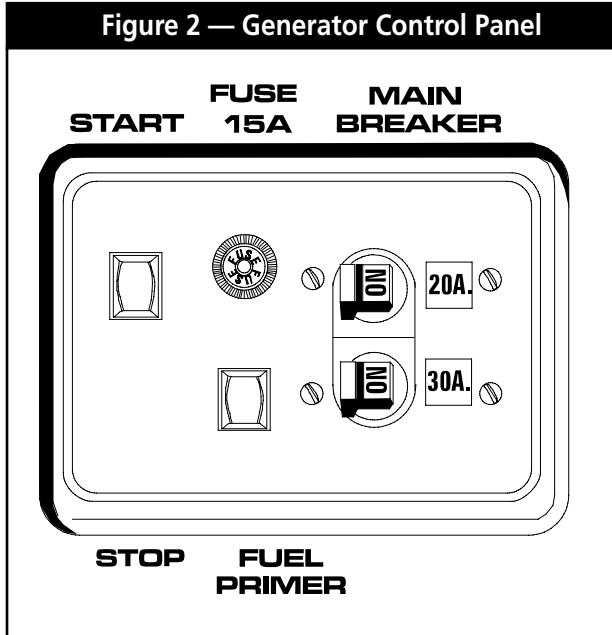

■ FUEL PRIMER

Before starting a cold engine (if it has not been started in more than two weeks), you must press this switch to bring fuel from the tank to the fuel regulator. This rocker type switch springs back into its original position when you release it.

■ START/STOP SWITCH

To crank and start the engine, hold this switch at its START position. Release the switch when the engine starts. To stop an operating engine, press and hold the switch in its STOP position until the engine shuts off. The switch center position is the RUN position.

■ FUSE

Protects the engine DC control circuit against electrical overload. If the fuse element has melted open due to overloading, the engine cannot be cranked. If you must replace it, use only an identical replacement fuse.

■ MAIN BREAKER

Protects generators AC output circuit against overload and provides a method of turning OFF the generators 120/240 volts AC output to vehicle circuits. The NP-50LPG has one 20 amp breaker and one 30 amp breaker.

NOTE: If the Series NP-50LPG has been reconnected for dual voltage AC output (120/240 volts), you can install line breakers having an amperage rating that is different than stated above. The replacement line breakers consist of two separate breakers with a connecting piece between the breaker handles (so that both breakers will operate at the same time). If the unit is reconnected for dual voltage, **IT IS NO LONGER RVIA LISTED.**

OPTIONAL REMOTE START/STOP PANEL

A remote mounted Start/Stop Panel is available, which allows you to start and stop the generator engine conveniently from inside the vehicle.

Figure 3 — Optional Remote Panel (Model 9042)

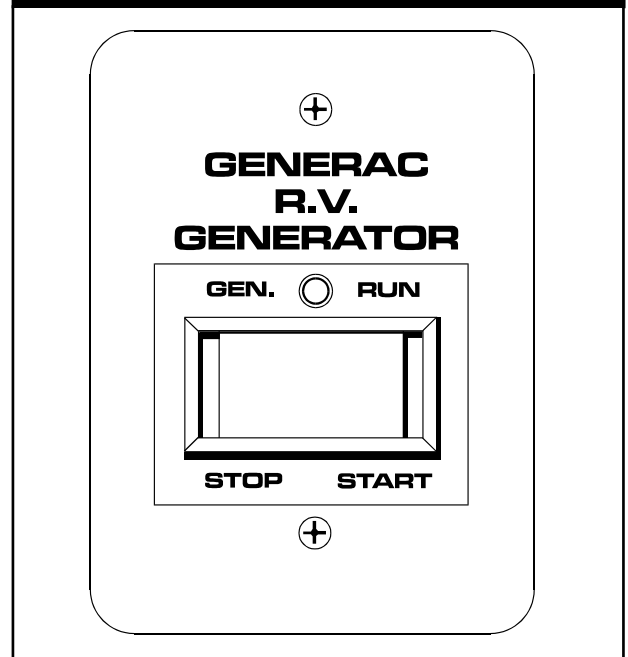



BEFORE STARTING THE ENGINE

IMPORTANT: INSTRUCTIONS AND INFORMATION IN THIS MANUAL ASSUME THE GENERATOR HAS BEEN PROPERLY INSTALLED, CONNECTED, SERVICED, TESTED AND ADJUSTED BY A QUALIFIED INSTALLATION TECHNICIAN OR INSTALLATION CONTRACTOR.

■ INSTALLATION

Generator installation must have been properly completed so it complies with all applicable codes, standards and regulations and with the manufacturer's recommendations.

■ ENGINE LUBRICATION

Have engine crankcase properly serviced with recommended oil before starting. Refer to MAINTENANCE and SPECIFICATIONS sections for oil servicing procedures and recommendations.



CAUTION: Any attempt to crank or start the engine before you have properly serviced it with the recommended oil may result in an engine failure.

■ FUEL SUPPLY

The engine must have adequate supply of proper fuel to operate. Before starting, check that sufficient fuel is available.

■ COOLING AND VENTILATING AIR

Air inlet and outlet openings in generator compartment must be open and unobstructed for continued proper operation. Without sufficient cooling and ventilating air flow, the engine-generator quickly overheats which causes it to shutdown and it could damage the generator.

■ ENGINE EXHAUST GAS

Before starting the generator engine, you should be sure there is no way for exhaust gases to enter the vehicle interior and endanger people or animals. Close windows, doors and other openings in the vehicle that, if open, might permit exhaust gases to enter the vehicle.



DANGER: The generator engine gives off DEADLY carbon monoxide gas through its exhaust system. This dangerous gas, if breathed in sufficient concentrations, can cause unconsciousness or even death. **DO NOT OPERATE THE GENERATOR IF THE EXHAUST SYSTEM IS LEAKING OR HAS BEEN DAMAGED. SYMPTOMS OF CARBON MONOXIDE POISONING ARE (a) inability to think coherently; (b) vomiting; (c) twitching muscles; (d) throbbing temples; (e) dizziness; (f) headaches; (g) weakness and sleepiness. IF YOU FEEL ANY OF THESE SYMPTOMS, MOVE INTO FRESH AIR IMMEDIATELY. IF SYMPTOMS PERSIST, GET MEDICAL HELP.**

STARTING THE GENERATOR

IMPORTANT: Read the vehicle manufacturer's instructions. The owner/operator should become familiar with the vehicle in which the generator is installed. Differences exist between vehicles. For example, some vehicles may use a transfer switch to isolate dockside power from the generator, while other vehicles may use an isolating receptacle. Some vehicles may be equipped with a DC converter which allows the generator to power certain DC lighting and other DC loads.

To start the generator from either the generator control panel or from the optional Remote Panel, proceed as follows:

1. Turn OFF electrical loads, using whatever means provided in your vehicle (such as a main line circuit breaker or transfer switch).

NOTE: If starting from the generator panel, turn OFF loads by setting the generator's main circuit breaker to "OFF" or "OPEN". If starting from a Remote Panel, turn OFF loads using whatever means is provided in the vehicle (such as a main circuit breaker). Electrical load circuits will be turned ON after the generator has started, stabilized and warmed up.

2. If you have not started the engine in more than two weeks, press the Fuel Primer switch and hold it for about 30 seconds to prime fuel system. However, if the engine is warm, skip Step 2.



- 3. Hold the engine Start/Stop Switch at START to crank engine. Release the switch when the engine starts.



CAUTION: If the engine does not start after it has been cranking for 15 seconds, release the start/stop switch and try again. Holding the switch for longer than 15 seconds can damage the starter motor.

- 4. Let the engine run at no-load for a few minutes to stabilize and warm up.
- 5. Turn ON electrical loads, using whatever means provided (such as a main circuit breaker or transfer switch).

STOPPING THE GENERATOR

- 1. Turn OFF all electrical loads, using whatever means provided (such as a main circuit breaker or transfer switch).
- 2. Let unit run a few minutes to stabilize temperature.
- 3. Hold the Start/Stop switch in its STOP position until engine comes to a complete stop.

APPLYING LOADS TO GENERATOR

When applying electrical loads to the generator, observe these guidelines:

- Before applying electrical loads, let the generator stabilize and warm up for a minute or two.
- DO NOT overload the generator.

LET ENGINE STABILIZE

The generator supplies correct rated voltage only at proper governed speed. Some electrical appliances may be extremely sensitive to voltage. Incorrect voltages can damage those appliances.

If electrical loads are applied at reduced operating speeds, such loads imposed on the engine when sufficient power is not available may shorten engine life. Never turn ON electrical loads until after the generator engine has started and stabilized ON-speed.

DO NOT OVERLOAD THE GENERATOR

You can read the rated wattage/ampere capacity of your generator on the generator data decal (see "Identification Record" on Page 3).

Applying electrical loads in excess of the unit's rated capacity will cause the engine-generator to automatically shutdown.

To avoid overloading, add up the wattage of all connected electrical lighting, appliance, tool and motor loads. This total should not be greater than the generator's rated wattage capacity.

Most lighting, appliance, tool, and motor loads indicate their required watts on their nameplate or data plate. For light bulbs, simply note the wattage rating of the bulb.

If a load does not show its rated wattage, multiply that load's rated VOLTS times AMPS to obtain WATTS.

WATTAGE REFERENCE GUIDE

	RUNNING WATTS		RUNNING WATTS
*Air Conditioner (12,000 Btu)	1700	Lawn Mower	1200
Battery Charger (20 amp)	500	Light Bulb	100
Belt Sander (3")	1000	Microwave Oven.....	700
Chain Saw	1200	*Milk Cooler	1100
Circular Saw (6-12")	800 to 1000	Oil Burner on Furnace	300
Coffee Maker	1000	Oil Fired Space Heater (140,000 Btu)	400
*Compressor (1HP)	2000	*Paint Sprayer, Airless (1/3 HP)	600
*Deep Freeze	500	Radio.....	50 to 200
Disc Sander (9")	1200	*Refrigerator.....	600
Electric Range (one element)	1500	Slow Cooker.....	200
Electric Skillet.....	1250	*Submersible Pump (1-1/2 HP)	2800
*Furnace Fan (1/3 HP)	1200	*Submersible Pump (1 HP)	2000
Hair Dryer.....	1200	*Table Saw (10")	1750 to 2000
Hand Drill (1").....	1100	Television	1750 to 2000
Hedge Trimmer	450		
Impact Wrench	500		

* Allow 2-1/2 times the listed watts for starting these devices.

Induction type motors (such as those that run the vehicle's furnace fan, refrigerator, air conditioner, etc.) need about 2-1/2 time more watts of power for starting than for running (for a few seconds during motor starting). Be sure to allow for this when connecting electrical loads to the generator. First, figure the watts needed to start electric motors in the system. To that figure, add the running wattages of other items that will be operated by the generator.

Do not apply heavy electrical loads for the first two or three hours of operation.

ADDITIONAL INFORMATION

This section discusses some the the engine protective devices, overload protection and breaking in a new generator.

AUTOMATIC LOW OIL PRESSURE SHUTDOWN

The engine is equipped with a normally-closed (N.C.) oil pressure switch (Figure 4). Engine oil pressure holds the switch open during cranking and operation. Should oil pressure drop below a pre-set level, the switch contacts close and the engine automatically shuts down.

HIGH TEMPERATURE SHUTDOWN

A temperature switch (Figure 4) with normally-open (N.O.) contacts is mounted near the oil filter. If engine temperature were to exceed about 284°F (140°C), the switch contacts close and the engine shuts down.

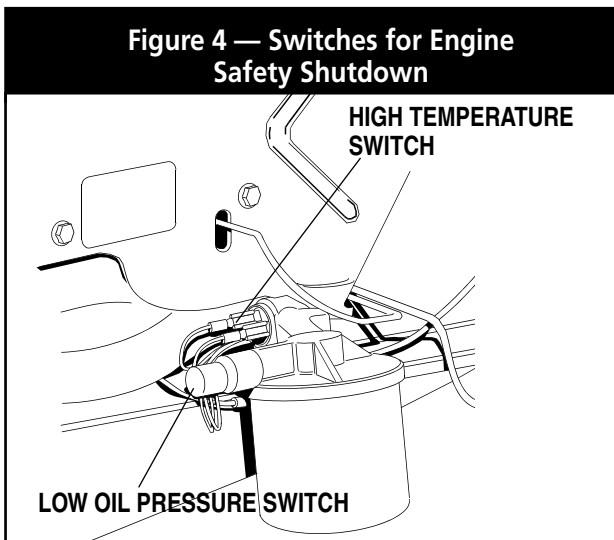

FIELD BOOST

The Controller Circuit Board houses a field boost diode and resistor which are part of a "field boost" circuit (Figure 5). During engine cranking only, a positive DC (battery) voltage is delivered through the diode, resistor, brushes and slip rings, and the generator rotor. Application of this voltage to the rotor "flashes the field" whenever it is started. Flashing of the field each time the generator starts makes sure that a sufficiently strong magnetic field is available to produce "pick-up" voltage in the stator windings.

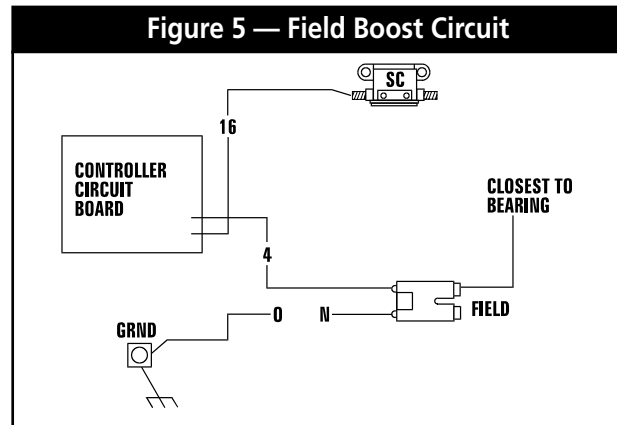

OVERVOLTAGE PROTECTION

A solid state voltage regulator (Figure 6) controls the generator's AC output voltage. This regulator supplies an excitation voltage to the rotor. By regulating the rotor's excitation current, the strength of its magnetic field is regulated and, in turn, the voltage delivered to connected electrical loads is controlled. When the AC frequency is 60 Hz, voltage is regulated at 120 volts (voltage-to-frequency ratio is 2-to-1).

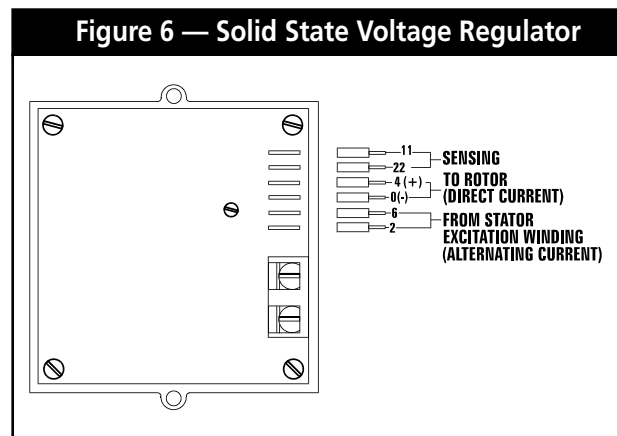



The voltage regulator also incorporates a “voltage surge protection circuit.” This circuit prevents troublesome surges in the generator AC output voltage. Voltage surge is a common cause of damage to electronic equipment.

■ 25-HOUR BREAK IN PERIOD

The first 25 hours of operation is the break-in period for the generator. Properly breaking in the generator is essential to minimize fuel consumption and provide maximum engine performance. During this 25-hour break in period, follow this procedure:

- Run the unit at varying electrical loads, to help seat engine piston rings properly.
- For the 75-hour operation following the break in period, avoid light electrical loads. Load the generator at 50% (or more) of its rated wattage capacity. Repeated light loads during these 75 hours can cause improper seating of engine piston rings, resulting in blowby and high oil consumption.
- Check engine oil level frequently. Add oil if needed. It is normal for the generator engine to consume more oil than is normal until the piston rings have properly seated.
- After operating the unit for 25 hours, complete the tasks recommended under “25-Hour Check Up.”

■ 25-HOUR CHECK UP

After the 25-hour break-in period, contact an authorized service facility for the following maintenance. The vehicle owner is responsible for any charges:

- Change engine crankcase oil and oil filter.
Check oil level.
- Inspect cooling and ventilation openings.
Check engine carburetor.
- Check engine ignition system.
- Inspect entire electrical system.
- Inspect the engine exhaust system.

■ OPERATION IN HIGH GRASS OR BRUSH



WARNING: NEVER OPERATE THE GENERATOR WHILE THE VEHICLE IS PARKED IN HIGH GRASS, WEEDS, BRUSH OR LEAVES. SUCH MATERIALS CAN IGNITE AND BURN FROM THE HEAT OF THE EXHAUST SYSTEM. THE GENERATOR EXHAUST BECOMES EXTREMELY HOT DURING OPERATION AND REMAINS HOT FOR A LONG TIME AFTER IT HAS SHUT DOWN.

■ ATTENTION REQUIRED AFTER SUBMERSION

If the recreational vehicle generator has been submerged in water, it must NOT be started or operated. Following any submersion in water, have an authorized Generac Service Facility thoroughly clean and dry the generator.

■ OPERATING PRECAUTIONS

Never operate the generator set while the vehicle is parked over dry leaves, dry grass or any other combustible substance. The generator’s exhaust system becomes extremely hot and can cause fire if it is too close to combustible materials. The generator’s exhaust system gives off DEADLY carbon monoxide gas. This dangerous gas, if breathed in sufficient concentrations, can cause unconsciousness and even death. Never operate the generator set with the vehicle inside any garage or enclosed area. Never operate the generator if it has a leaky exhaust system. Close windows in the vicinity of the generator exhaust outlet and take any other steps to prevent exhaust gases from entering rooms or areas occupied by people or animals.

■ EFFECTS OF MOISTURE AND DIRT

Keep the generator set as clean and dry as possible. Protect the unit against excessive dust, dirt, corrosive vapors, road splash, etc. Permitting dirt and moisture to accumulate on generator windings will have an adverse effect on the insulation resistance of those windings. When moisture is allowed to remain in contact with windings, some of the moisture will be retained in voids and cracks in the insulation. This causes a reduced insulation resistance and will eventually cause problems. Dirt will make the problem worse, since dirt tends to hold moisture in contact with windings. Salt (as from sea air) will also worsen the problem since it tends to absorb moisture from the air. Salt and moisture, when combined, form a good electrical conductor.



FUEL REQUIREMENTS

The "NP" series generator is equipped with a liquefied petroleum (LP) gas fuel system. LP gas is usually supplied as a liquid in pressure tanks.

"NP" series generators require a "vapor withdrawal" type fuel system. This type of gaseous fuel system uses the vapors forming above the liquid fuel in the storage tank. Air temperature around the storage tank must be high enough to sustain adequate fuel vaporization. In colder climates, you may need to use an independent heat source to be sure the fuel sufficiently vaporizes in the storage tank.

LP gas may consist of propane, butane or a mixture of two gases. Using fresh HD-5 LP is recommended. Fuel should not contain more than 2.5% butane. Propane vaporizes at temperatures as low as -20°F (-29°C), but butane returns to its liquid state when the temperature drops below about 32°F (0°C). For that reason, a higher ratio of propane is desired in the gas mixture when temperatures drop below freezing.

FUEL CONSUMPTION

(CUBIC FEET PER HOUR)

The following lists the approximate amount of fuel the unit consumes at 100% rated load. Actual fuel consumption may vary depending on BTU content of fuel, applied load, ambient conditions, engine condition, etc.

Propane47 cubic ft. per hour

ENGINE OIL REQUIREMENTS

Use a high quality detergent oil classified "For Service SF" and with an oil viscosity rating of SAE 10W-30 oil. Do not pour in any additives to the recommended oil. Engine crankcase capacity is 1.5 U.S. quarts (1.4 liters). See MAINTENANCE section for oil level check and filling procedures.

SPECIFICATIONS

ENGINE

Type of Engine	GN-410, single-cylinder
Cooling Method	Air-cooled
Rated Horsepower	15 at 4200 RPM
Displacement	407cc
Cylinder Block	Aluminum with cast iron sleeve
Type of Governor	Mechanical, fixed speed
Air Cleaner	Paper element with foam pre-cleaner
Starter	12 volt DC electric
Ignition System	Solid State
Recommended Spark Plugs	
Champion	RC12YC
AC	R45S
Autolite	65
Spark Plug Gap.....	0.030 inch (0.76mm)

GENERATOR

Rotor RPM	3600
Rotor Poles.....	2
Engine RPM.....	2571
Rated Maximum Continuous	
AC Output	4500 watts (4.5 kW)
Voltage	120 volts*
Rated Maximum Continuous AC Current.....	37.5 amperes
Phase	single
Frequency.....	60 Hertz
Weight	197 pounds (93 kg)
Length	25 inches (635mm)
Width	18.5 inches (470mm)
Height	15.75 inches(400mm)

* The unit is reconnectable to 120 and/or 240 volts, dual voltage output. Rated maximum continuous current at 240 volts is 18.8 amps.

This section includes information about simple maintenance which includes the following tasks.

- Checking engine oil level
- Changing engine oil
- Changing oil filter
- Clean or change the air cleaner
- Cleaning the air intake screen
- Cleaning spark plug

CHECKING ENGINE OIL LEVEL

Check engine crankcase oil level at least every eight hours of operation, or before you use it.

Be sure the generator is as level as possible.

- Remove OIL DIPSTICK (Figure 7) and wipe it dry with clean, lint-free cloth.
- Install and tighten oil dipstick then remove again.
- Oil level should be at the dipstick "FULL" mark. If necessary, add oil to the "FULL" mark only. **DO NOT FILL ABOVE THE "FULL" MARK.**
- Install and tighten oil dipstick before operating the engine.

NOTE: See "Engine Oil Requirements" on Page 12 for recommended oils.

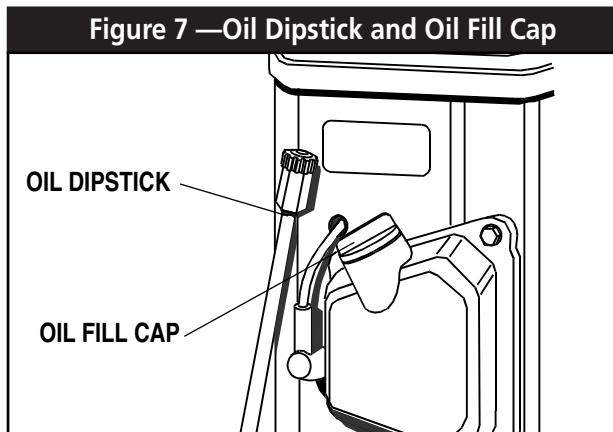

CHANGE ENGINE OIL

Change engine oil after the first 25 hours of operation (after the 25-hour break-in period, Page 11). Thereafter, change oil every 50 operating hours. Change oil more frequently if operating consistently under heavy load or at high ambient temperatures. To change oil, proceed as follows:

- Run engine for at least 5 minutes, then shut down.

- With engine still warm, remove oil drain cap from oil drain hose (Figure 8). Drain oil completely into a suitable container.

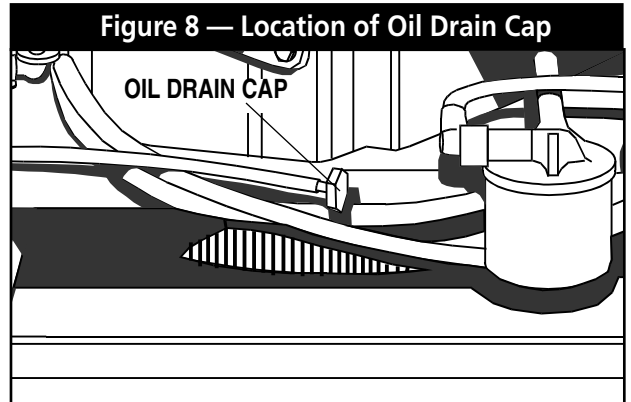

- When oil has drained, install and tighten oil drain cap.
- Remove oil fill cap and fill crankcase with the recommended oil (see Page 12). The engine crankcase can hold about 1.4 liters. **DO NOT FILL ABOVE "FULL" MARK.**
- Install and tighten oil dipstick and oil fill cap before operating engine.

CHANGE OIL FILTER

Change engine oil filter after the first 25 hours of operation, every 100 operating hours thereafter.

- Turn oil filter counterclockwise to remove (Figure 9).
- Coat gasket of new filter with engine oil.
- Turn new filter clockwise until its gasket contacts lightly with the filter adapter. Then tighten with an additional 3/4 to one turn by hand.
- Run engine and check for leaks.

NOTE: Check oil level and fill to full mark after checking for leaks. Filter will retain some oil.

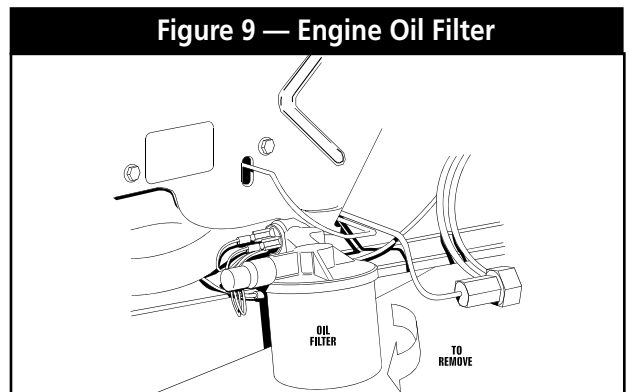

ENGINE AIR CLEANER

Clean and re-oil the foam pre-cleaner every three months or every 25 operating hours, whichever comes first. Service more frequently if operating under extremely dusty or dirty conditions (Figure 10):

- Remove both screws to loosen cover.
- Remove the COVER, FOAM PRE-CLEANER and PAPER FILTER.
- Remove foam pre-cleaner from cover.
- Wash foam pre-cleaner in liquid detergent and water.
- Wrap foam pre-cleaner in a cloth and squeeze dry.
- Saturate foam pre-cleaner in engine oil. Squeeze to remove excess oil (Do not twist foam pre-cleaner).
- Install foam pre-cleaner into cover, followed by paper filter.
- Install cover, foam pre-cleaner and paper filter.
- Tighten both screws to retain.

Once each year or every 100 hours of operation (whichever comes first), replace the paper filter. The new replacement filter must be a flame retardant type.

Figure 10 — Engine Air Cleaner

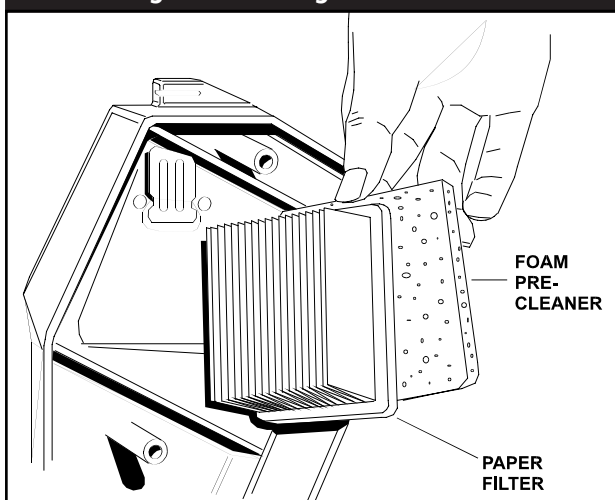

■ CLEAN OR REPLACE AIR FILTER

Remove air cleaner cover; then remove foam pre-cleaner (service if necessary) and remove paper filter.

Clean air filter by tapping it gently on a solid surface. If the filter is too dirty, replace it with a new one. Dispose of the old filter properly.

Clean air cleaner cover then insert pre-cleaner into cover. Next insert new paper filter into cover to hold pre-cleaner in place and assemble all of them to the base of the air cleaner.

CLEAN AIR INTAKE SCREEN

Clean all foreign material from air intake screen (Figure 11) at least once every 100 hours of operation. Clean more often if necessary.

Inspect the area around the generator exhaust muffler periodically and remove all grass leaves, dirt, etc. from this area.

Figure 11 — Cleaning Air Intake Screen

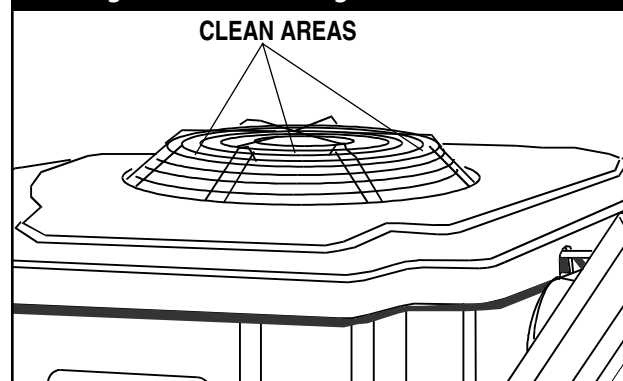

ENGINE SPARK PLUG

Clean engine spark plug and set gap to 0.030 inch (0.76mm) every 100 hours of operation (Figure 12). Clean by scraping or wire brushing and washing with commercial solvent. DO NOT BLAST CLEAN SPARK PLUG.



CAUTION: Sparking can occur if wire terminal does not fit firmly on spark plug terminal end. If necessary, reform wire terminal to obtain a tight fit.

Figure 12 — Setting Spark Plug Gap

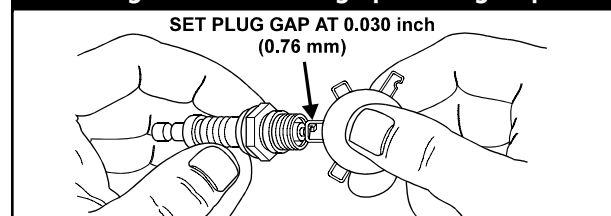

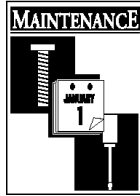

SPARK ARRESTOR MUFFLER

If the generator is not equipped with a spark arrestor exhaust muffler and is to be used on any forest covered, brush covered or grass covered unimproved land, you may have to install a spark arrestor. The spark arrestor must be maintained in effective working order by the vehicle owner/operator.

For assistance in ordering, installing and maintaining spark arrestor exhaust mufflers, contact your nearest authorized service facility.

Exhaust mufflers supplied by Generac are spark arrestor types. Generac exhaust muffler for recreational vehicle generators do not have a spark arrestor screen, but are of the more efficient "toroid" or "swirl" type. To remove carbon and combustion deposits from such mufflers, remove the PLUG from the muffler and run engine for about 15 minutes. Shut engine down, let the muffler cool and install the plug.



WARNING: BE SURE TO RE-INSTALL THE PLUG FROM THE MUFFLER TIGHTLY. ENGINE VIBRATION COULD CAUSE A LOOSE PLUG TO FALL OUT. WITHOUT THE PLUG IN PLACE, HOT ENGINE EXHAUST IS DIRECTED OUT THE OPENING. THIS HOT EXHAUST, DEPENDING ON THE INSTALLATION, COULD BE DIRECTED TO AREAS NOT ABLE TO WITHSTAND THE EXTREME HEAT SUCH AS WOODEN FLOOR BOARDS OR OTHER FLAMMABLE MATERIAL. THIS COULD RESULT IN A FIRE.

CLEANING THE GENERATOR

Keep your generator set as clean and dry as possible. Dirt and moisture that are permitted to accumulate on electrical windings have an adverse affect on the insulation resistance of those windings.

Moisture that is allowed to remain in contact with windings will be retained in voids and cracks of the windings. Dirt makes the problem worse, since it tends to hold the moisture into contact with the windings. Salt, as from sea air, worsens the problem since it tends to absorb moisture from the air. The combination of salt and moisture makes a good electrical conductor.



CAUTION! Do NOT use a forceful spray of water to clean the generator. Water will enter the generator interior and cause problems, and may also contaminate the generator fuel system.

BATTERY

All lead-acid storage batteries will discharge when not in use. The generator battery should be inspected as follows:

■ ONCE WEEKLY

Inspect battery posts and cables for tightness, corrosion. Clean and/or tighten as needed.

Also check battery fluid level, and, if necessary, fill with DISTILLED WATER ONLY. DO NOT USE TAP WATER IN BATTERY.

■ EVERY SIX MONTHS

Have battery state of charge and condition checked. This should be done with an automotive type battery hydrometer.



DANGER: STORAGE BATTERIES GIVE OFF EXPLOSIVE HYDROGEN GAS. THIS GAS CAN FORM AN EXPLOSIVE MIXTURE AROUND THE BATTERY FOR SEVERAL HOURS AFTER CHARGING. THE SLIGHTEST SPARK CAN IGNITE THE GAS AND CAUSE AN EXPLOSION. SUCH AN EXPLOSION CAN SHATTER THE BATTERY AND CAUSE BLINDNESS OR OTHER INJURY. ANY AREA THAT HOUSES A STORAGE BATTERY MUST BE PROPERLY VENTILATED DO NOT ALLOW SMOKING, OPEN FLAME, SPARKS OR ANY SPARK PRODUCING TOOLS OR EQUIPMENT NEAR THE BATTERY.



DANGER: BATTERY ELECTROLYTE FLUID IS AN EXTREMELY CAUSTIC SULFURIC ACID SOLUTION THAT CAN CAUSE SEVERE BURNS. DO NOT PERMIT FLUID TO CONTACT EYES, SKIN, CLOTHING, PAINTED SURFACES, ETC. WEAR PROTECTIVE GOGGLES, PROTECTIVE CLOTHING AND GLOVES WHEN HANDLING A BATTERY. IF YOU SPILL THE FLUID, FLUSH THE AFFECTED AREA IMMEDIATELY WITH CLEAR WATER.



DANGER: DO NOT USE ANY JUMPER CABLES OR BOOSTER BATTERY TO CRANK AND START THE GENERATOR ENGINE. IF ANY BATTERY HAS DISCHARGED, REMOVE IT FOR RECHARGING.

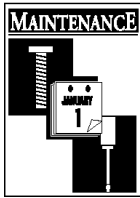

MAJOR SERVICE MANUAL

To obtain a service manual for your generator, order it from your dealer/distributor or contact the factory. Be sure to identify your MODEL NUMBER and SERIAL NUMBER.

DRIVE BELT

The engine drives the generator rotor by means of a pulley and drive belt arrangement. The drive belt and pulleys are warranted for the life of the generator. Drive belt tension was properly adjusted before the unit was shipped from the factory. If you suspect that drive belt tension is incorrect, contact an authorized service facility.

EXERCISING THE GENERATOR

Generac recommends that you start and operate the generator at least once every seven days. Let the unit run for at least 30 minutes to "exercise" the engine.

OUT OF SERVICE PROTECTION

If you cannot exercise the generator every seven days and it is to be out of service longer than 30 days, prepare the generator for storage as follows:

- Start the engine and let it warm up.
- Close the fuel shutoff valve in the fuel supply line and let the engine "run out of fuel."
- While the engine is still warm from running, drain the oil completely. Refill crankcase with SAE 10W30 oil having API classification "For Service SF."
- Attach a tag to the engine indicating the viscosity and classification of the oil in the crankcase.

- Remove spark plug and pour about two or three tablespoons of clean, fresh engine oil into spark plug threaded opening. Crank engine several times to distribute oil, then install and tighten spark plug.
- Remove the battery and store in a cool, dry room on a wooden board. Never store the battery on concrete or earth floors.
- Clean and wipe the entire generator.

RETURN THE UNIT TO SERVICE AFTER STORAGE

To return the unit to service after storage, proceed as follows:

- Check tag on engine for oil viscosity and classification. Verify that the correct recommended oil is used in engine. If necessary, drain and refill with proper oil.
- Check battery. Fill all cells to the proper level with distilled water. **DO NOT USE TAP WATER IN THE BATTERY.** Recharge battery to 100% state of charge, or, if defective, replace the battery.
- Turn OFF all electrical loads, add fuel if necessary, then start the engine.
- Let the engine warm up.
- Apply electrical loads to at least 50% of the unit's rated wattage capacity.
- When engine is thoroughly warmed up, shut it down.
THE GENERATOR IS NOW READY FOR SERVICE.



TROUBLESHOOTING POINTS

PROBLEM	CAUSE	CORRECTION
Engine won't crank.	<ol style="list-style-type: none"> 15 amp fuse blown. Loose, corroded or defective battery cables Battery is discharged or defective. Defective starter contactor. Defective starter motor. Defective Controller circuit board 	<ol style="list-style-type: none"> Replace fuse. Tighten, clean or replace as necessary. Recharge or replace battery. Replace if defective. Replace if defective. Replace if defective.
Engine cranks but won't start	<ol style="list-style-type: none"> Out of fuel Fuel shutoff valve is closed. Defective Controller circuit board Spark plug defective. Defective ignition coil on engine Defective carburetor Dirty air cleaner. Fuel solenoid is defective. 	<ol style="list-style-type: none"> Replenish fuel. Open fuel shutoff valve. Replace if defective. Clean, regap or replace plug. Replace if defective. Replace if defective. Clean or replace elements as needed. Replace or repair.
Engine starts hard, runs rough.	<ol style="list-style-type: none"> Dirty air cleaner. Defective spark plug. Defective ignition coil. 	<ol style="list-style-type: none"> Clean or replace elements as needed. Clean, regap or replace plug. Replace if defective.
Engine starts, shuts down when Start/Stop switch is released.	<ol style="list-style-type: none"> Engine oil level is low. Engine is overheated. Defective Low Oil Pressure Switch Defective Controller circuit board. 	<ol style="list-style-type: none"> Check oil and add oil as needed. Check cooling system for blockage. Replace defective switch. Replace defective board.
No AC output from generator.	<ol style="list-style-type: none"> Check main line circuit breaker. Transfer switch (if so equipped) is set to wrong position. Failure in vehicle electrical system. Generator component failure. 	<ol style="list-style-type: none"> Reset to ON or CLOSED. Reset transfer switch. See vehicle manual. Contact an authorized service facility.

ELECTRICAL DATA

Drawing No. 94210

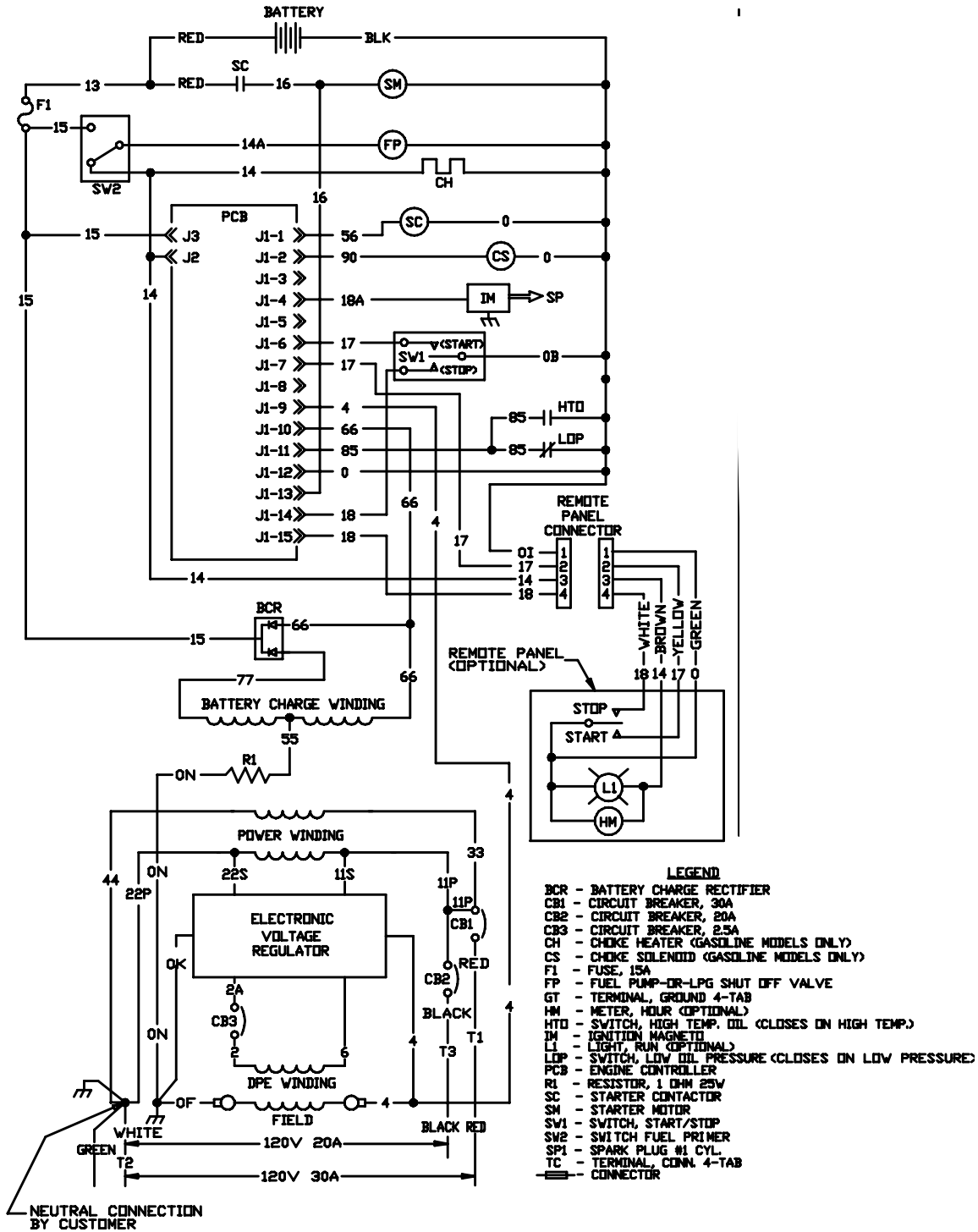

ELECTRICAL DATA

Drawing No. 94210

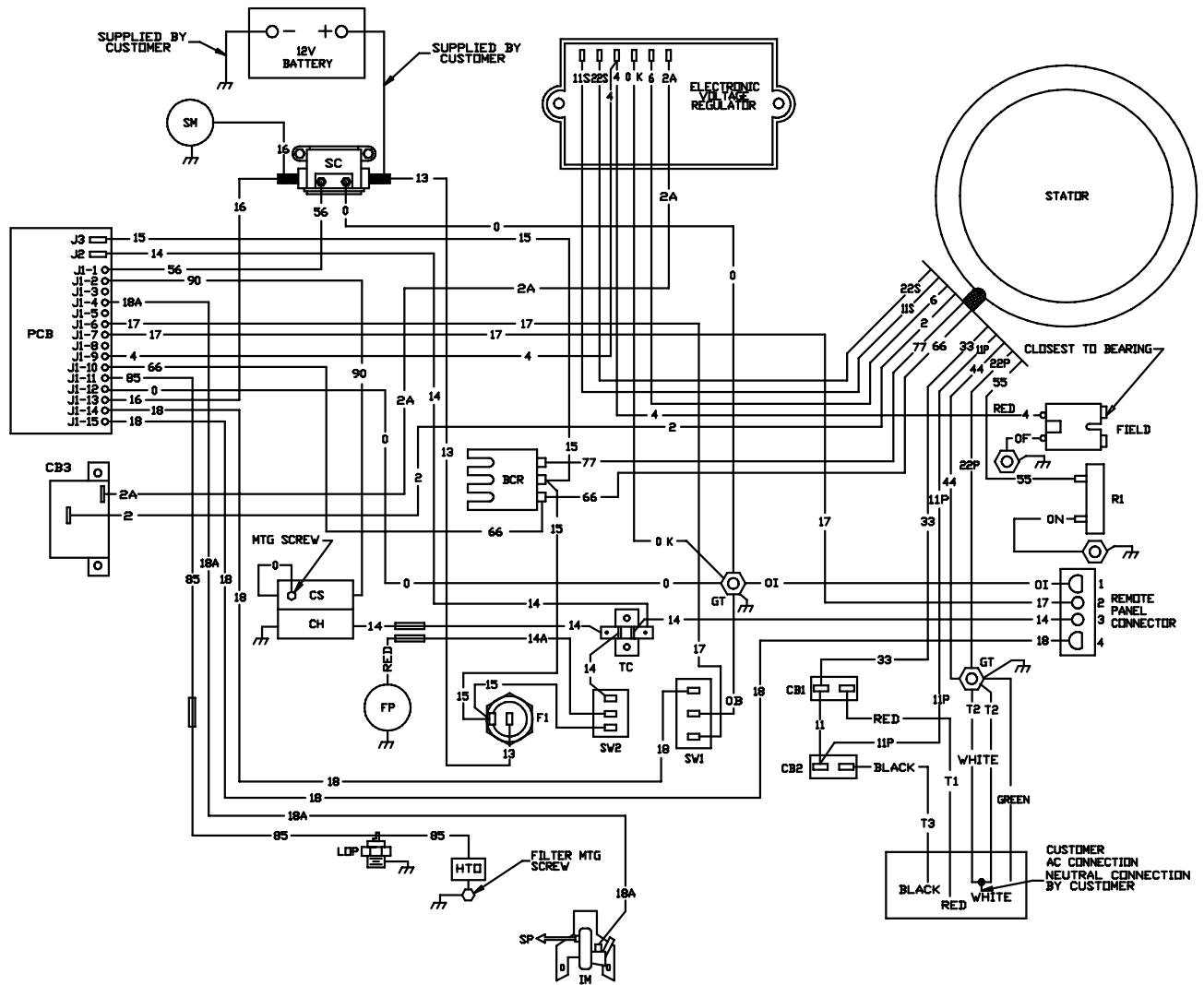

EXPLODED VIEW — BASE AND PULLEYS

Drawing No. 95865

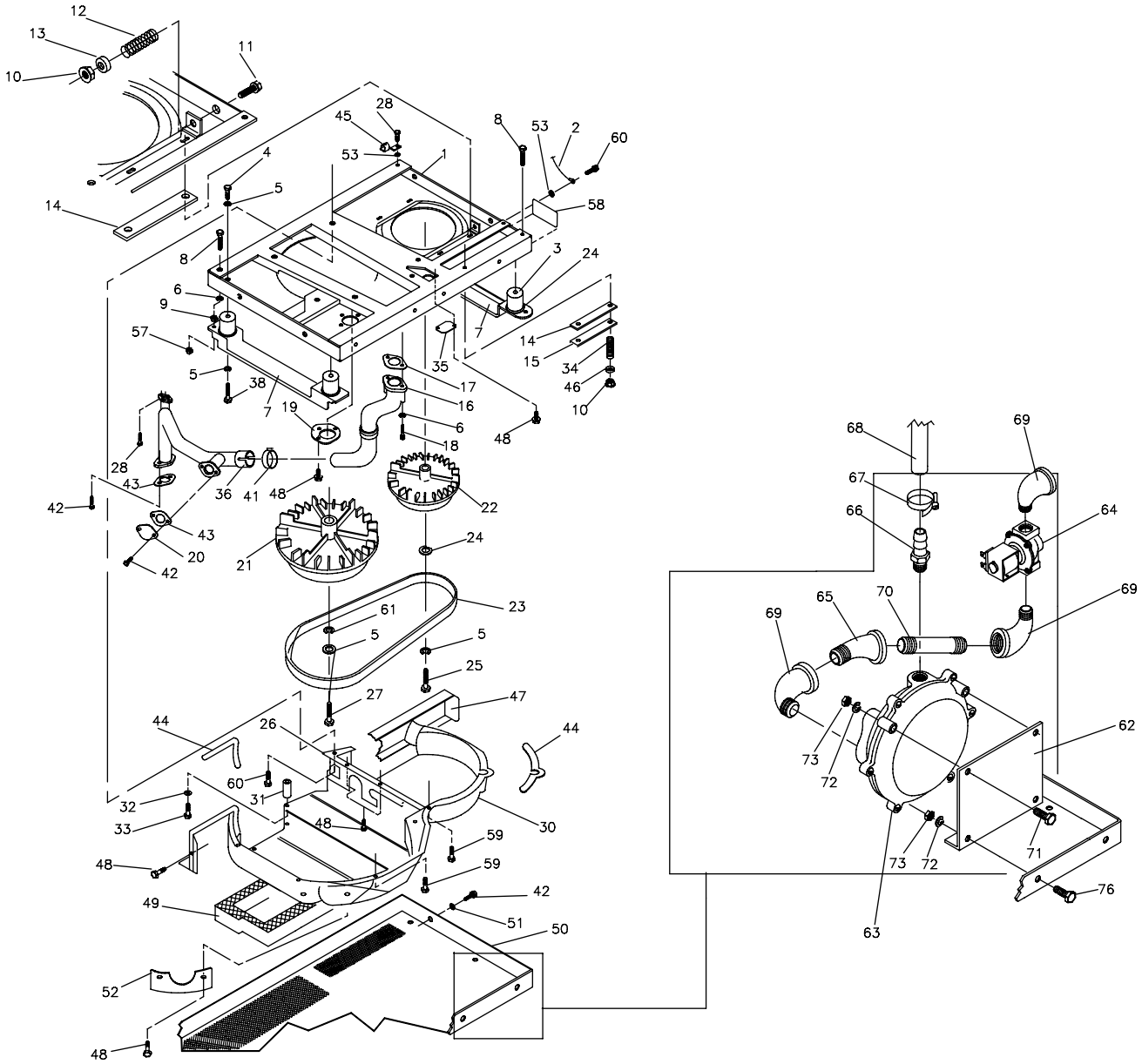



REPAIR PARTS — BASE AND PULLEYS

Drawing No. 95865

ITEM	DESCRIPTION	PART NO.	QTY.	ITEM	DESCRIPTION	PART NO.	QTY.
1	BASE, MOUNTING	92603	1	36	ADAPTOR, UNIVERSAL EXH.	91146	1
2	GROUND CABLE	90141	1	41	CLAMP, EXH. PIPE-1-1/4 DIA.	96289	1
3	MOUNT, (RUBBER)	46911	4	42	HHCS & LOCK WASH.-M6-1.0x16.	79246	8
4	CAPSCREW, -.3/8"-16 x 1/2"	25017	8	43	GASKET, EXH. PIPE	77643	2
5	LOCKWASHER-M10	46526	10	44	FOAM TAPE	29289	10FT.
6	LOCKWASHER-M8	22129	4	45	LUG, GROUNDING	62684	1
7	SKID, RUBBER MOUNT	72391	2	46	WASHER, SPRING RETAINER	75237	4
8	SAFETY BOLT 5/16"-18 x 3 1/2"	77603	2	47	COVER, AIR OPENING	75226	1
9	NUT, HEX-5/16-18	22259	2	48	SCREW(CRIMPTITE) #10-24 x .5	56893	12
10	NUT, FLANGED LOCK-M8-1.25	52858	6	49	GASKET, FOAM-SLIDE PAN	75229	1
11	CAPSCR. -M8-1.25 x 60MM	51730	2	50	PAN, SLIDE	75227	1
12	SPRING, BELT TENSION	29459	2	51	FLAT WASHER-M6	22473	4
13	WASHER, SPRING CNTR.	75215	2	52	COVER, EXHAUST OUTLET	72384-C	1
14	SLIDE (NYLON)	73146	4	53	LOCK WASHER, SHAKEPR.-M6	22447	2
15	SUPPORT, NYLON SLIDE	75209	2	57	NUT, FLANGE-5/16-18 (SPECIAL)	81105	2
16	MANIFOLD, EXHAUST	91032	1	58	DECAL, GROUND	67210A	1
17	GASKET, EXHAUST MANIFOLD	90239	1	59	SCREW, TAPTITE M5-0.8 x 10 .	74908	9
18	CAPSCR.,-M8-1.25 x 65 LG.	57636	2	60	SCREW, TAPTITE M6-1.0 x 10	45756	5
19	GASKET, COLLECTOR PAN	92645	1	61	FLAT WASHER-M10	22131	1
20	COVER PLATE -EXTERNAL	90859	1	62	REGULATOR MOUNT .BRACK.	78864	1
21	PULLEY, ENGINE	75224-B	1	63	REGULATOR	75211	1
22	PULLEY, ALT.	73106-B	1	64	FUEL SOLENOID 12VDC	A2666	1
23	BELT (POLY V 4L)-40"	75216	1	65	45° STREET ELBOW-3/4"	25425	1
24	WASHER, PULLEY RETAINER	49451	1	66	STRAIGHT BARB. FIT.-1/2 x 3/8"	63463	1
25	CAPSCR., HEX HD. 3/8"-24 x 1"	42633	1	67	HOSE CLAMP-SIZE-#8	57822	1
26	GUIDE, BLOWER HOUSING	77017	1	68	FUEL HOSE-1/2" DIA. x 8.50"	74994	1
27	CAPSCR., 3/8"-24 x 2-1/2"	73118	1	69	90 °STREET ELBOW-3/4"	26307	3
28	SCREW (TAPTITE)-M6-1.00 x 20	74906	2	70	PIPE, NIPPLE-3/4" x 3" LG	26881	1
30	HOUSING, BLOWER	72375	1	71	M6-1.0 x 30 CAP SCREW	38750	2
31	SPACER, BLOWER HOUSING	73185	1	72	M6 LOCK WASHER	22097	4
32	LOCKWASHER, M5	22152	1	73	M6 HEX NUT	49813	4
33	CAPSCR. -M5-0.80 x 80MM	77682	1	74	FLEX SLEEV.-3/8" x 9" Lg.	84409	1
34	SPRING, GENERATOR SET MT	75242	4	75	PIPE JOINT COMPOUND	55162	A/R
35	COVER PLATE, EXH. BASE	92203	1	76	M6 x 16 HEX HD. CAPSCR.	47411	2

EXPLODED VIEW — ALTERNATOR AND PANEL

Drawing No. 94106

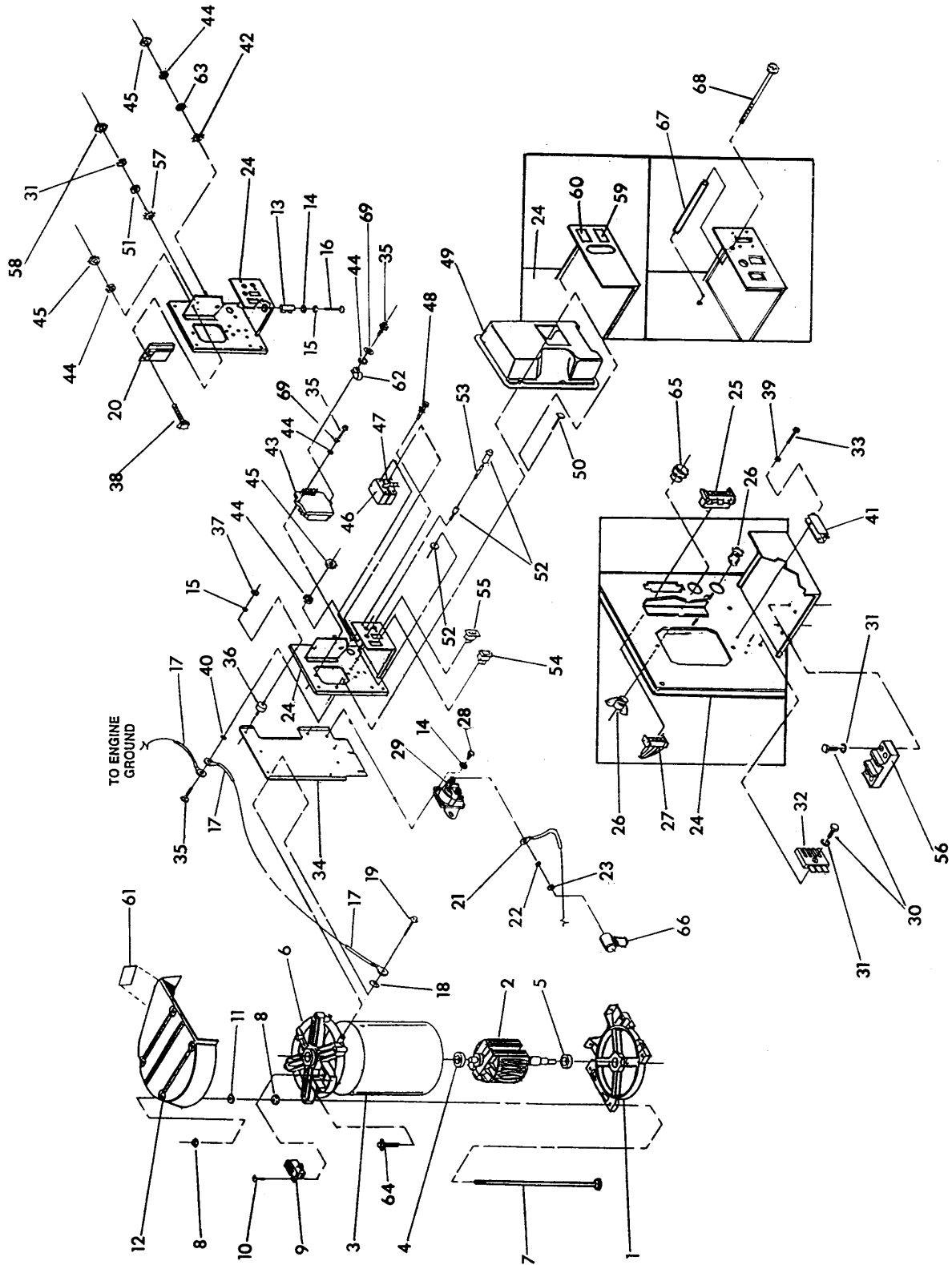



REPAIR PARTS — ALTERNATOR AND PANEL

Drawing No. 94106

ITEM	DESCRIPTION	PART NO.	QTY.	ITEM	DESCRIPTION	PART NO.	QTY.
1	Lower Bearing Carrier	75995	1	35	M5-0.8 x 30 Capscrew	75235	3
2	50 Rotor Assembly	92605G	1	36	Vibration Mount	82737	4
3	50 Stator Assembly	92604G	1	37	M6-1.0 Hex Nut	49813	4
4	Ball Bearing	73159	1	38	M5-0.8 x 16 Capscrew	55440	1
5	Ball Bearing	31971	1	39	M3 Lock Washer	43182	2
6	Upper Bearing Carrier	72379	1	41	2.5A.-ON Circuit Breaker	53623	1
7	Stator Stud	77006	4	42	M5 Shakeproof Washer	22769	2
8	M8-1.25 Flange Lock Nut	52858	8	43	Regulator Voltage	83049	1
9	Brush Holder	66386	1	44	M5 Lock Washer	22152	6
10	M5-0.8 x 16 Taptite	66849	2	45	M5-0.8 Hex Nut	51716	4
11	Nylon Washer	27756	4	46	20A. Circuit Breaker	90144	1
12	Generator Top Housing	86314	1	47	30A All Units Cir. Breaker	90145	1
13	Resistor	75234	1	48	#6-32 w/Lockwasher Screw	25105	4
14	M6 Flat Washer	22473	3	49	Panel Cover	86315	1
15	M6 Lock Washer	22097	5	50	M4-0.7 x 16 Screw w/Lock Washer & Flat Washer	90734	4
16	M6-1.0 x 60 Capscrew	74095	1	51	M4 Flat Washer	22985	1
17	Ground Cable	90141	2	52	Fuse Holder	32300	1
18	Shakeproof Lock Washer	22447	1	53	15A. AGC Fuse	22676	1
19	M6-1.0 x 20 Taptite	74906	4	54	6A (Start/Stop) S.P.D.T. Switch	87798	1
20	P.C.B. Controller	94039	1	55	S.P.D.T. Switch (Fuel Pump)	92113	1
21	Starter Cable	10-74260	1	56	Terminal Block	75210A	1
22	5/16 Lock Washer	22129	2	57	M4 Shakeproof Washer	23365	1
23	5/16-18 Hex Nut	22259	2	58	M4-0.7 Hex Nut	51715	1
24	Panel Sheet Metal	86316	1	59	30A. CB Rating Decal	90157	1
25	4-Pin Connector	53650	1	60	20A. CB Rating Decal	90156	1
26	Connector	91915	1	61	Cust. Connection Decal	89438A	1
27	Remote Harness	75244	1	62	Hose Clamp	31791	1
28	M6-1.0 x 12mm Capscrew w/Lock Washer	66476	2	63	M5 Flat Washer	23365	1
29	Starter Contactor	86729	1	64	M5 x 10 Taptite	74908	2
30	M4-0.7 x 16 Capscrew	75476	3	65	Bushing	23484S	1
31	M4 Lock Washer	22264	4	66	Battery Cable Boot	75763A	1
32	Battery Charge Rectifier	65795	1	67	Plastic Spacer	94070	1
33	M3-0.5 x 15 Capscrew	90987	2	68	M6-0.8 x 110 PPHMS.	94071	1
34	Panel Support Bracket	86317	1				

EXPLODED VIEW — ENGINE ENCLOSURE

Drawing No. 94108

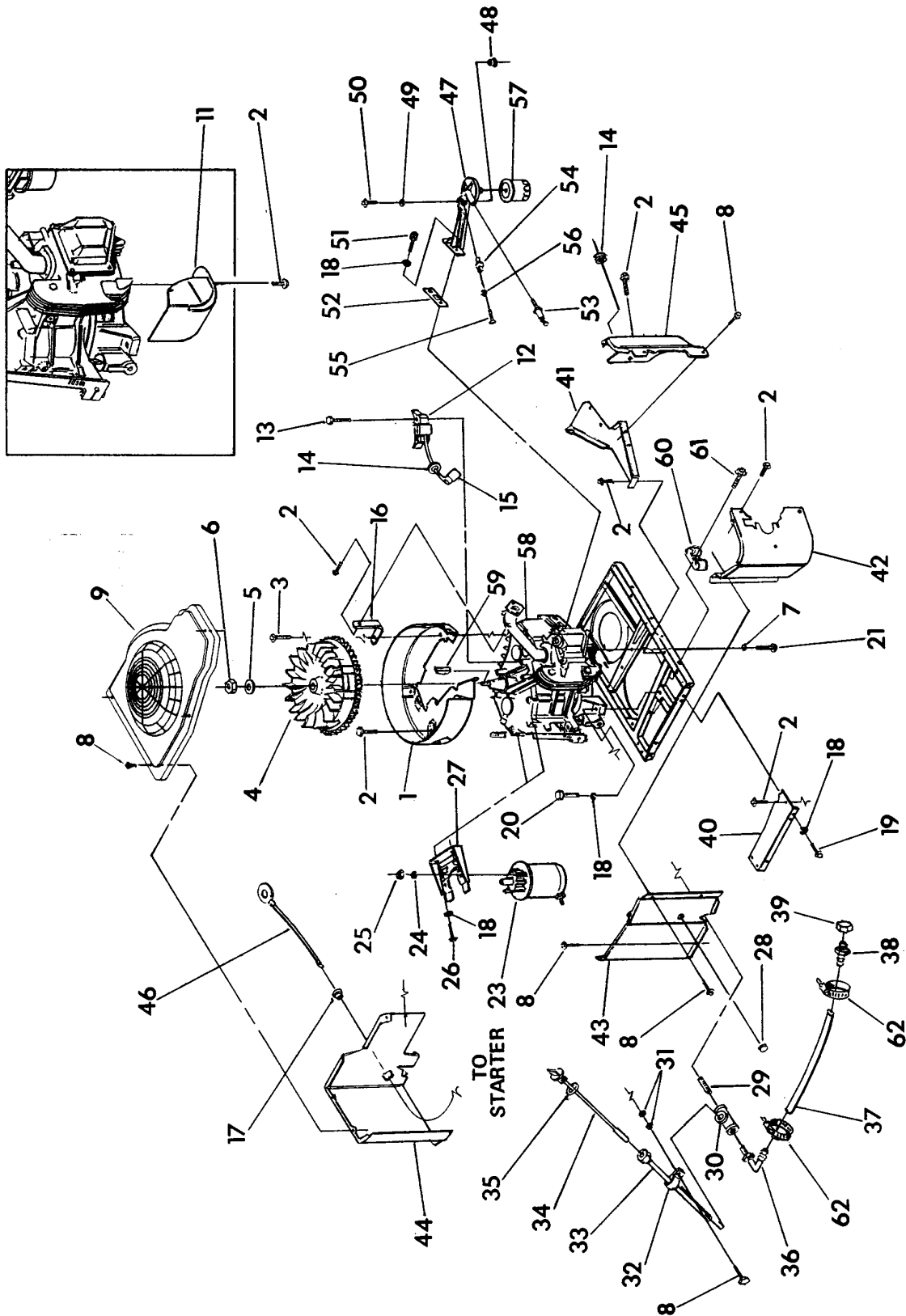



REPAIR PARTS — ENGINE ENCLOSURE

Drawing No. 94108

ITEM	PART NO.	QTY.	DESCRIPTION	ITEM	PART NO.	QTY.	DESCRIPTION
1	90953	1	SCROLL, FLYWHEEL	36	43790	1	ELBOW, 3/8 I.D. -BRASS
2	45756	8	SCREW, TAPTITE M6-1.0 x 10 LG	37	47290	1	HOSE, 3/8 I.D.
3	90388	1	SCREW, TAPTITE M6-1.0 x 12 LG	38	35461	1	BARB FITTING-1/4" NPT 3/8 HOSE
4	91222-A	1	FLYWHEEL (20 DEG.)	39	69811	1	CAP-1/4" NPT
5	67198-N	1	WASHER, BELLVILLE M20	40	90951	1	COVER-BASE, STARTER SIDE
6	67890	1	NUT, M20 x 1.5	41	90952	1	COVER-BASE, CARB. SIDE
7	A4456	1	3/8" SPECIAL LOCK WASHER	42	91137	1	WRAPPER, ENGINE SPARK PLUG
8	56893	23	SCREW, CRIMPTITE #10-24 x .5 LG	43	90954	1	WRAPPER, STARTER SIDE
9	98769	1	COVER, TOP FLYWHEEL NP50	44	90955	1	WRAPPER, REAR GEAR CASE
11	91646	1	DEFLCT., EXHAUST PORT	45	90956	1	WRAPPER, CARB. SIDE
12	92572	1	ASSY., IGNITION COIL	46	74260-10	1	ASSEMBLY., WIRE STARTER(#16)
13	92079	2	SCREW, TAPTITE M6-1.0 x 25MM	47	90892	1	SUPPORT, OIL FILTER
14	22717-A	1	GROMMET, RUBBER	48	91159	1	BUSHING, RUBBER
15	73132	1	BOOT, SPARK PLUG	49	91160	1	WASHER, RUBBER
16	91643	1	BRACKET, INTAKE MANIFOLD SUPPORT	50	91161	1	BOLT, SHOULDER M6 x 15 LG
17	22717-B	1	GROMMET, RUBBER	51	49821	2	BOLT, SOCKET HD. CAPSCR.-M8-1.25 x 30 LG
18	22129	8	LOCK WASHER-M8	52	86999	1	GASKET, OIL FILTER SUPPORT
19	42907	2	CAPSCR., HEX HD. M8-1.25 x 16 LG	53	60108	1	SWITCH, OIL PRESSURE 10 PSI
20	57821	2	CAPSCR., HEX HD. M8-1.25 x 40 LG	54	75281	1	SWITCH, OIL TEMP.
21	59637	2	SCREW, TAPTITE 3/8-16 x .75 LG	55	74027	2	SCREW, PHILIPS PAN HD. MACH.-M3-.05 x 5 LG
23	21544	1	MOTOR, STARTER-12VOLT	56	43182	2	LOCK WASHER-M3
26	40976	2	SOCKET HD. CAPSCR., M8-1.25 x 20 LG	57	70185	1	FILTER, OIL
28	25034	1	PLUG, BUTTON-1.06	58	90783-A	1	ENGINE, LONG BLOCK GN360RV
29	35467	1	CLOSE NIPPLE 3/8 NPT		99673	1	ENGINE, LONG BLOCK GN410VSRV
30	27738-A	1	PIPE TEE 3/8" NPT	59	82774	1	KEY, WOODRUFF 4 x 19 DIA.
31	22145	2	FLAT WASHER	60	65852	1	CLIP, HOSE RETAINER
32	55934-T	1	CLAMP-VINYL COATED	61	74908	1	SCREW, TAPTITE M5-0.8 x 10 LG
33	91519	1	TUBE-DIPSTICK	62	48031E	2	HOSE CLAMP
34	91520	1	ASSY., CAP AND DIPSTICK				
35	91648	1	<169>O<170> RING DIA. 14 x 3 WALL				

EXPLODED VIEW — GN-410 ENGINE **Drawing No. B2195**

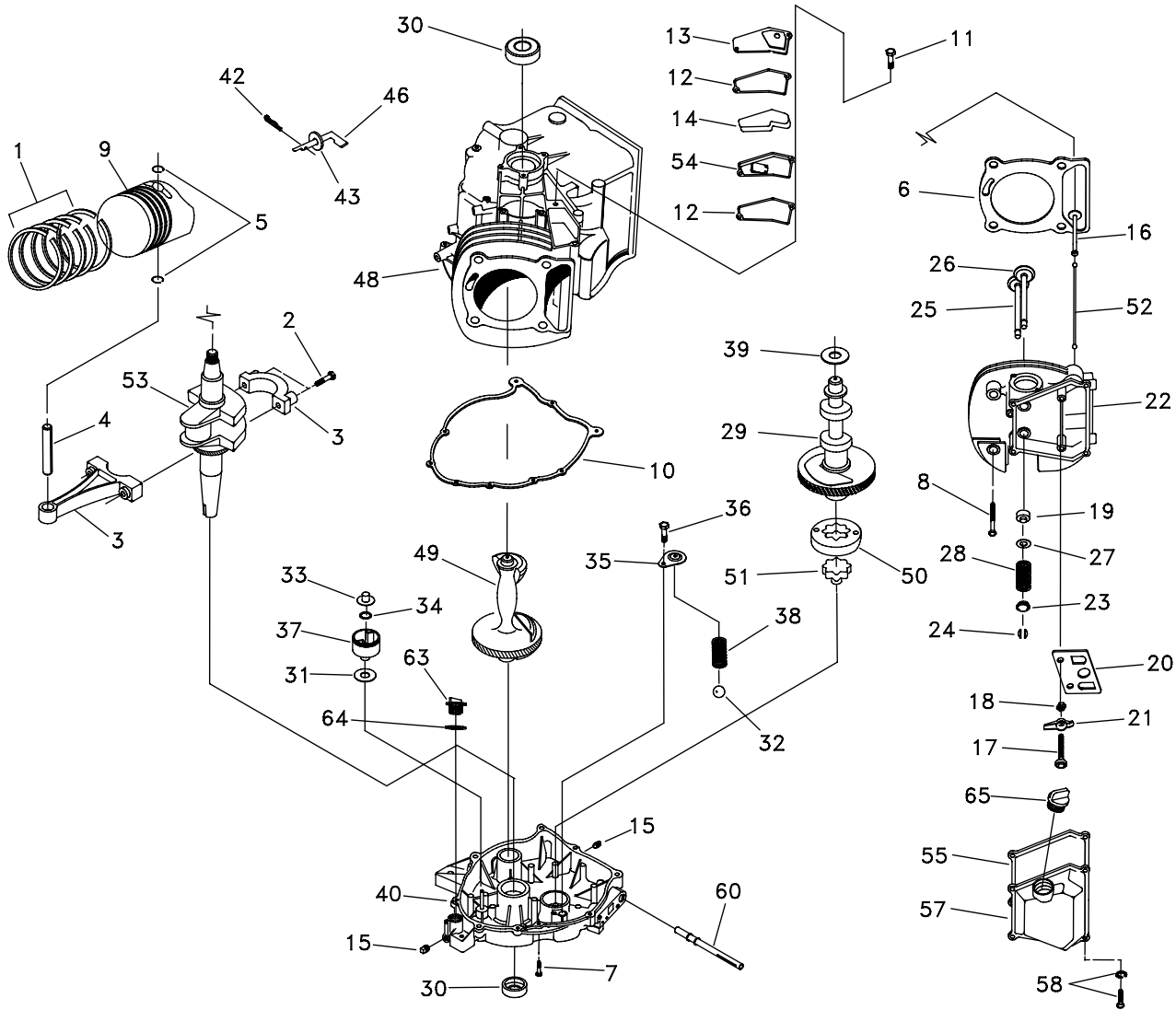



REPAIR PARTS — GN-410 ENGINE

Drawing No. B2195

ITEM	PART NO.	QTY.	DESCRIPTION	ITEM	PART NO.	QTY.	DESCRIPTION
1	71977	1	PISTON RING SET	33	76365	1	GOVERNOR SPOOL
2	71979	2	CONNECTING ROD BOLT	34	78645	1	GOVERNOR RETAINER (C-RING)
3	72637	1	CONNECTING ROD WITH CAP AND BOLT	35	78691	1	OIL PRESSURE SPRING RETAINER
4	71980	1	PISTON PIN	36	74908	1	M5-0.80 x 8MM SCREW (THD. FORMING)
5	71983	2	PISTON PIN RETAINER	37	83912	1	GOVERNOR GEAR ASSEMBLY
6	73142	1	CYLINDER HEAD GASKET	38	83918	1	OIL PRESSURE SPRING
7	73144	8	FLANGED HEX HD. CAPSCREW	39	72662	1	GOVERNOR SHAFT
8	73149	4	M10 x 100MM HEAD BOLT	40	83961A	1	OIL SUMP
9	76339	1	PISTON	41	72654	1	SLEEVE BEARING
10	76701	1	CRANKCASE GASKET	42	78658	1	GOVERNOR ARM "R" PIN
11	78698	2	M6 SCREW (THD. FORMING)	43	78659	2	THRUST WASHER
12	80308	2	BREATHER GASKET	44	78699B	1	SLEEVE DOWEL PIN DIA. 12
13	80309	1	BREATHER COVER	45	78699C	2	SLEEVE DOWEL PIN DIA. 14
14	80338	1	OIL BREATHER SEPARATOR	46	83948	1	GOVERNOR ARM
15	20527	1	DECAL, ENGINE IDENTIFICATION	47	87710	1	DOWEL PIN DIA. 12 x 20 LONG
16	83897	2	TAPPET	48	89288A	1	CRANKCASE SUB ASSEMBLY
17	72694	2	PIVOT BALL STUD	49	84430	1	BALANCER
18	72696	2	JAM NUT (ROCKER ARM)	50	86002	1	OUTER GEROTOR
19	78672	1	SEAL, VALVE STEM	51	86026	1	INNER GEROTOR
20	78694	1	PUSH ROD GUIDE PLATE	52	88396B	2	PUSH ROD
21	83907	2	ROCKER ARM	53	90416	1	CRANKSHAFT ASSEMBLY
22	83923	1	CYLINDER HD. W/VALVE SEATS AND GUIDES	54	90747	1	BREATHER VALVE ASSEMBLY
23	86514	2	VALVE SPRING RETAINER	55	71987	1	ROCKER COVER GASKET
24	86515	4	VALVE SPRING KEEPER	57	92362	1	ROCKER COVER W/FILL
25	86516	1	EXHAUST VALVE	58	92287	4	M6-1.00 x 16MM PAN HD. SCR. AND LOCKWASHER
26	86517	1	INTAKE VALVE	59	83921	1	BEARING TUBE SHAFT
27	89673	2	WASHER, VALVE SPRING	60	77158	1	OIL SCREEN PICKUP ASSEMBLY
28	91308	2	VALVE SPRING	61	80342	2	"O" RING 14 I.D. x 2.4 THICK
29	83932	1	CAMSHAFT ASSEMBLY	63	76329	1	OIL FILL PLUG
30	72655	2	CRANKSHAFT SEAL	64	86254	1	"O" RING 17.8 I.D. x 2.4 THICK
31	76361	1	THRUST WASHER	65	93064	1	OIL FILL CAP ASSEMBLY
32	76362	1	PRESSURE RELIEF BALL				

EXPLODED VIEW — ENGINE ACCESSORIES

Drawing No. 95866

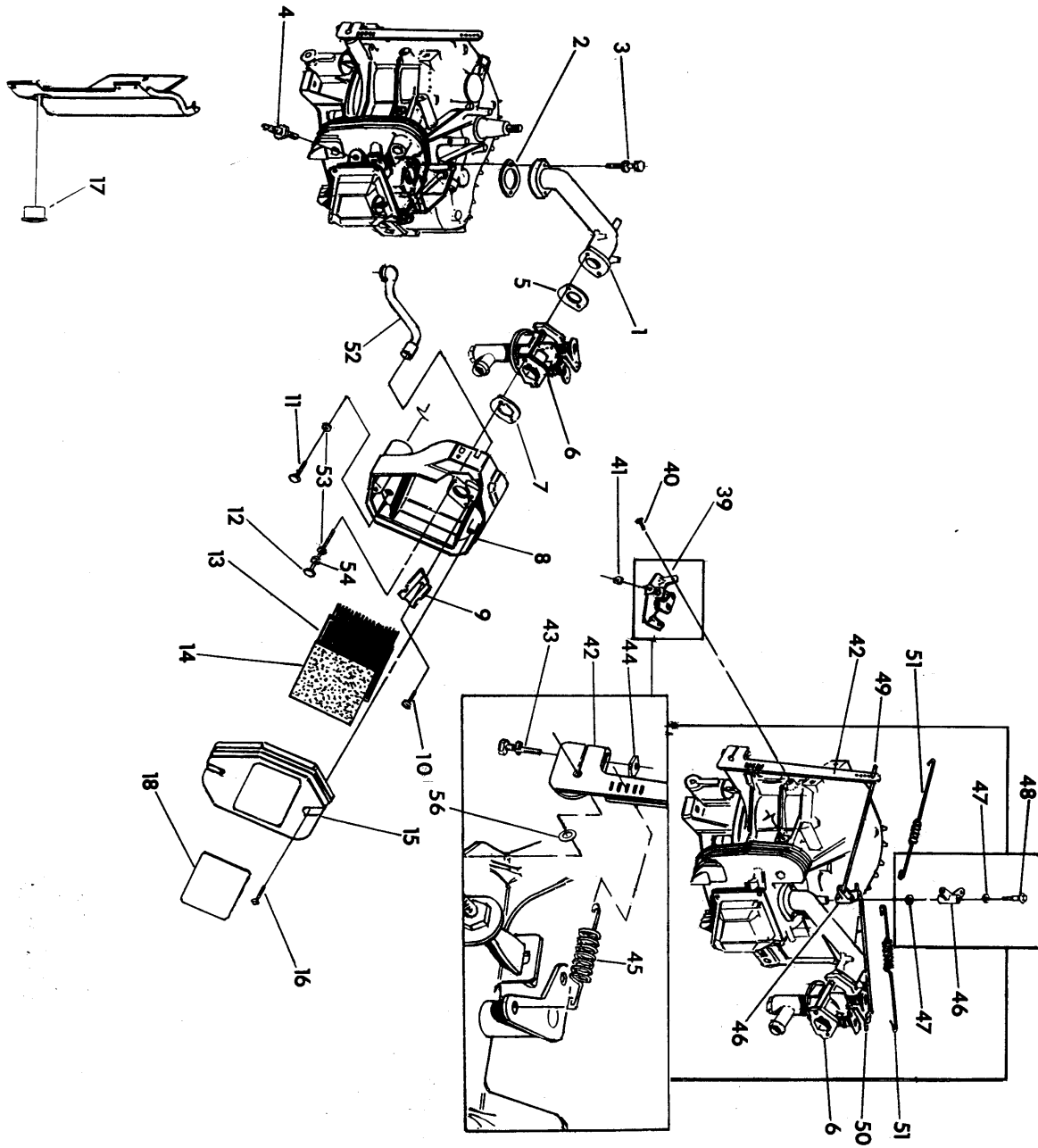



REPAIR PARTS — ENGINE ACCESSORIES **Drawing No. 95866**

ITEM	PART NO.	QTY.	DESCRIPTION	ITEM	PART NO.	QTY.	DESCRIPTION
1	90896	1	MANIFOLD, INTAKE	39	92164	1	ASSEMBLY, GOV. SPRING ADJ. BRACKET
2	91039	1	GASKET, MANIFOLD/HEAD				
3	68527	2	BOLT, HEX HD. CAPSCR. & LOCK WASHER-M6-1.0 x 20	40	83512	2	BOLT, TAPTITE M8 x 15 LG
				41	83503	1	NUT, LOCKING M5- 0.8
4	72347	1	SPARK PLUG, CHAMPION #RC12YC	42	91916	1	LEVER, GOVERNOR ARM
				43	83532	1	BOLT, HEX HD. WASHER /LOCK WASHER-M6 x 30
5	89228	1	GASKET, CARB./MANIFOLD				
6	A2775A	1	L/P CARBURETOR	44	86681	1	NUT, M6 SPECIAL
7	90970	1	GASKET, CARB./AIR FILTER	45	91638	1	SPRING, GOVERNOR
8	73108C	1	BASE, AIR FILTER	46	91633	1	BELLCRANK, GOV. RODS
9	91204	1	PLATE, CARB. SHIELD	47	92586	2	WASHER, FELT
10	59635	2	SCREW, PLASTITE #8 x .37"	48	91161	1	BOLT, SHOULDER M6 x 15
11	66476	2	BOLT, HEX HD. CAPSCR., & LOCK WASHER-M6 x 12 LG	49	91636	1	ROD, LINKAGE GOV. LEVER-BELLCRANK
12	92695	2	BOLT, CARB. MOUNT 80 LG	50	91637	1	ROD, LINKAGE BELLCRANK -CARB.
13	73111	1	FILTER, AIR				
14	81646	1	PRE-CLEANER, AIR FILTER	51	91649	2	SPRING, A/L GOV. LEVER-BELLCRANK
15	73104-B	1	COVER, AIR FILTER				
16	78609	2	BOLT, AIR FILTER COVER	52	91645	1	BREATHER TUBE
17	20139	1	SNAP BUSHING	53	22473	4	M6 FLAT WASHER
18	91554	1	DECAL, A/C DATA NP-50G (360 ENGINE ONLY)	54	22097	2	M6 LOCK WASHER
				55	A4009	1	SPRING WASHER
	91554B	1	DECAL, A/C DATA NP-50G (410 ENGINE ONLY)	56	A7029	1	NYLON WASHER, .31 X .26 X .13

CALIFORNIA EMISSION CONTROL WARRANTY STATEMENT

YOUR WARRANTY RIGHTS AND OBLIGATIONS

The California Air Resources Board ("CARB") and Generac Corporation are pleased to explain the Emission Control System Warranty on your new recreational vehicle generator engine. In California, new recreational vehicle generator must be designed, built and equipped to meet the State's stringent anti-smog standards. Generac Corporation will warrant the emission control system on your recreational vehicle generator for the periods of time listed below provided there has been no abuse, neglect, unapproved modification, or improper maintenance of your recreational vehicle generator engine.

Your emission control system may include parts such as the carburetor, ignition system and exhaust system. Also included may be the compression release system and other emission-related assemblies.

Where a warrantable condition exists, Generac Corporation will repair your recreational vehicle generator engine at no cost to you for diagnosis, parts and labor.

MANUFACTURER'S EMISSION CONTROL SYSTEM WARRANTY COVERAGE:

Emissions control systems on 1995 and later model year recreational vehicle generator are warranted for two years as hereinafter noted. If, during such warranty period, any emission-related part on your engine is defective in materials or workmanship, the part will be repaired or replaced by Generac Corporation.

OWNER'S WARRANTY RESPONSIBILITIES:

As the recreational vehicle generator engine owner, you are responsible for the performance of the required maintenance listed in your owners manual. Generac Corporation recommends that you retain all receipts covering maintenance on your recreational vehicle generator engine, but Generac Corporation will not deny warranty solely due to the lack of receipts or for your failure to provide written evidence of the performance of all scheduled maintenance.

As the recreational vehicle generator engine owner, you should, however, be aware that Generac Corporation may deny you warranty coverage if your recreational vehicle generator engine or a part thereof has failed due to abuse, neglect, improper maintenance or unapproved modifications.

You are responsible for presenting your recreational vehicle generator engine to a Generac Corporation Authorized Service Outlet as soon as a problem exists. The warranty repairs should be completed in a reasonable amount of time, not to exceed 30 days.

Warranty service can be arranged by contacting either a Generac Corporation Authorized Service Outlet or by contacting Generac Corporation at:

**GENERAC CORPORATION PH: (414) 544-4811
P.O. BOX 8 FAX: (414) 544-0179
WAUKESHA, WI 53187**

IMPORTANT NOTE: This warranty statement explains your rights and obligations under the Emission Control System Warranty ("ECS Warranty") which is provided to you by Generac Corporation pursuant to California law. See also the Generac Corporation Limited Warranties for Generac Corporation which is enclosed herewith on a separate sheet and also is provided to you by Generac Corporation. The ECS Warranty applies only to the emission control system of your new engine. To the extent that there is any conflict in terms between the ECS Warranty and the Generac Corporation Warranty, the ECS Warranty shall apply except in any circumstances in which the Generac Corporation Warranty may provide a longer warranty period. Both the ECS Warranty and the Generac Corporation Warranty describe important rights and obligations with respect to your new engine.

Warranty service can only be performed by a Generac Corporation Authorized Service Outlet. At the time of requesting warranty service, evidence must be presented of the date of the sale to the original purchaser. The purchaser shall pay any charges for making service calls and/or for transporting the products to and from the place where the inspection and/or warranty work is performed. The purchaser shall be responsible for any damage or loss incurred in connection with the transportation of any engine or any part(s) thereof submitted for inspection and/or warranty work.

IF YOU HAVE ANY QUESTIONS REGARDING YOUR WARRANTY RIGHTS AND RESPONSIBILITIES, YOU SHOULD CONTACT GENERAC CORPORATION AT **1-800-222-3136**

EMISSION CONTROL SYSTEM WARRANTY

Emission Control System Warranty ("ECS Warranty") for 1995 and Later Model Year recreational vehicle generator:

- A. Applicability: This warranty shall apply to 1995 and later model year recreational vehicle generator. The ECS Warranty Period ("ECS Warranty Period") shall begin on the date the new engine or equipment is delivered to its original, end-use purchaser and shall continue for 24 consecutive months thereafter.
- B. General Emissions Warranty Coverage: Generac Corporation warrants to the original, end-use purchaser of the new engine or equipment and to each subsequent purchaser that each of its recreational vehicle generator is:
1. Designed, built and equipped so as to conform with all applicable regulations adopted by the Air Resources Board pursuant to its authority, and
 2. Free from defects in materials and workmanship which, at any time during the ECS Warranty Period, will cause a warranted emissions - related part to fail to be identical in all material respects to the part as described in the engine manufacturer's application for certification.
- C. The ECS Warranty only pertains to emissions-related parts on your engine, as follows:
1. Any warranted, emissions-related parts which are not scheduled for replacement as required maintenance in the Owner's Manual shall be warranted for the ECS Warranty Period. If any such part fails during the ECS Warranty Period, it shall be repaired or replaced by Generac Corporation according to Subsection (4) below. Any such part repaired or replaced under the ECS Warranty shall be warranted for any remainder of the ECS Warranty Period.
 2. Any warranted, emissions-related part which is scheduled only for regular inspection as specified in the Owner's Manual shall be warranted for the ECS Warranty Period. A statement in such written instructions to the effect of "repair or replace as necessary" shall not reduce the ECS Warranty Period. Any such part repaired or replaced under the ECS Warranty shall be warranted for any remainder of the ECS Warranty Period.
 3. Any warranted, emissions-related part which is scheduled for replacement as required maintenance in the Owner's Manual shall be warranted for the period of time prior to first scheduled replacement point for that part. If the part fails prior to the first scheduled replacement, the part shall be repaired or replaced by Generac Corporation according to Subsection (4) below. Any such emissions-related part repaired or replaced under the ECS Warranty shall be warranted for the remainder of the ECS Warranty Period prior to the first scheduled replacement point for such emissions-related part.
 4. Repair or Replacement of any warranted, emissions-related part under this ECS Warranty shall be performed at no charge to the owner at a Generac Corporation Authorized Service Outlet.
 5. The owner shall not be charged for diagnostic labor which leads to the determination that a part covered by the ECS Warranty is in fact defective, provided that such diagnostic work is performed at a Generac Corporation Authorized Service Outlet.
 6. Generac Corporation shall be liable for damages to other original engine components or approved modifications proximately caused by a failure under warranty of any emission-related part covered by the ECS Warranty.
 7. Throughout the ECS Warranty Period, Generac shall maintain a supply of warranted emission-related parts sufficient to meet the expected demand for such emission-related parts.
 8. Any Generac Corporation authorized and approved emission-related replacement part may be used in the performance of any ECS warranty maintenance or repairs and will be provided without charge to the owner. Such use shall not reduce Generac Corporation ECS warranty obligations.
 9. Unapproved add-on modified parts may not be used to modify or repair a Generac Corporation engine. Such use voids this ECS Warranty and shall be sufficient grounds for disallowing an ECS Warranty claim. Generac Corporation shall not be liable hereunder for failures of any warranted parts of a Generac Corporation engine caused by the use of such an unapproved add-on or modified part.

EMISSION RELATED PARTS INCLUDE THE FOLLOWING:

1. Fuel Metering System
 - a. Gasoline carburetor assembly (if so equipped)
 - 1) Fuel Filter (if so equipped)
 - 2) Carburetor gaskets
 - 3) Fuel pump
 - b. LP/Natural gas carburetion assembly
 - 1) Fuel controller
 - 2) Mixer and its gaskets (if so equipped)
 - 3) Carburetor and its gaskets (if so equipped)
 - 4) Primary gas regulator (if so equipped)
 - 5) LP liquid vaporized (if so equipped)
2. Air cleaner assembly
 - a. Air filter element
 - b. Intake pipe
3. Ignition system including:
 - a. Spark plug
 - b. Ignition module
4. Catalytic muffler (if so equipped)
 - a. Muffler gasket (if so equipped)
 - b. Exhaust manifold (if so equipped)
5. Crankcase breather assembly and its components.
 - a. Breather connection tube



Generac's Three-Year Limited Warranty For Recreational Vehicle NP Generators

GENERAC warrants to the original purchaser that its generators will be free from defects in materials or workmanship for the period set forth below from the date of original purchase. During said warranty period, Generac will, at its option, repair or replace any part which, upon examination by Generac or Generac Authorized Distributors and/or Dealers, is found to be defective under normal use and service.

This warranty is effective only upon Generac's receipt prior to expiration of the warranty period of a completed Warranty Registration Card. This card is the only valid registration identification and must be presented at time of service. Claims will not be accepted without presentation of Registration Card.

THREE YEAR WARRANTY SCHEDULE

1. All NP Series generators used in a recreational vehicle shall be warranted for a period of three (3) years or 2,000 hours of operation, whichever occurs first. All parts, labor, removal and reinstallation shall be covered for the first two years. Parts and labor on selected generator and engine parts shall be covered during the third year or 2,000 hours, whichever occurs first. These selected parts are limited to: the main Rotor and Stator, Computer Control board (if applicable) with regard to the generator; the Cylinder Block, Cylinder Head, Crankshaft, Piston, Valve, Valve Lifter, and Manifolds with regard to the engine.
2. The drive train belt and pulleys (if so equipped) on NP air-cooled generator used in recreational vehicles shall be warranted against failure due to defective materials or normal usage for the life of the generator. For the original owner, this drive train warranty shall include parts and labor plus \$50.00 payment upon return of the failed belt or pulley by the original owner. For succeeding owners, this power train warranty shall cover belt or pulley parts only.
3. Rental units, demonstrators, prime power, or commercial applications, such as construction or utility, are warranted for (1) one year or 2,000 hours, whichever comes first.

THIS WARRANTY DOES NOT COVER:

- Costs of maintenance, installation, and start-up.
- Failures due to (a) normal wear and tear from GN engine, or (b) accident, misuse, abuse, negligence or improper installation.
- Products which are modified or altered in a manner not authorized by Generac in writing.
- Any incidental, consequential or indirect damages caused by defects in materials or workmanship, or any delay in repair or replacement of defective parts.
- Failure due to misapplication.
- Telephone, telegraph, teletype or other communication expense.
- Living or travel expenses of persons performing service.
- Any and all transportation/travel expenses.
- Rental equipment used while warranty repairs are being performed.
- Overtime labor.
- Starting batteries, fuses, light bulbs, and engine fluids.

****NORMAL WEAR: As with all mechanical devices, the GN-Series engines need periodic parts service and replacement to perform well. This warranty will not cover repair when normal use has exhausted the life of a part or an engine.**

There is no other express warranty. Generac hereby disclaims any and all implied warranties, including but not limited to those of merchantability and fitness for a particular purpose to the extent permitted by law. The duration of any implied warranties which cannot be disclaimed is limited to the time period (one year) as specified in the express warranty. Liability for consequential, incidental or special damages under any and all warranties is excluded to the extent permitted by law. Some states do not allow limitations on how long an implied warranty lasts, or the exclusion or limitation of incidental or consequential damages, so the above limitations or exclusions may not apply to you. This warranty gives you specific legal rights and you may also have other rights, which vary from state to state.

For service, see your nearest GENERAC authorized warranty service facility or call 1-800-333-1322. Warranty service can be performed only by a GENERAC authorized service facility. This warranty will not apply to service at any other facility. At the time of requesting warranty service, evidence of original purchase date must be presented.

Generac Corporation

P.O. Box 8

Waukesha, WI 53187

Telephone: (414) 544-4811

Fax: (414) 544-4851