

DIAGNOSTIC REPAIR Manual

MOBILE GENERATORS

IM, NP and Q-Series
with Engine Controller Circuit Board 92234

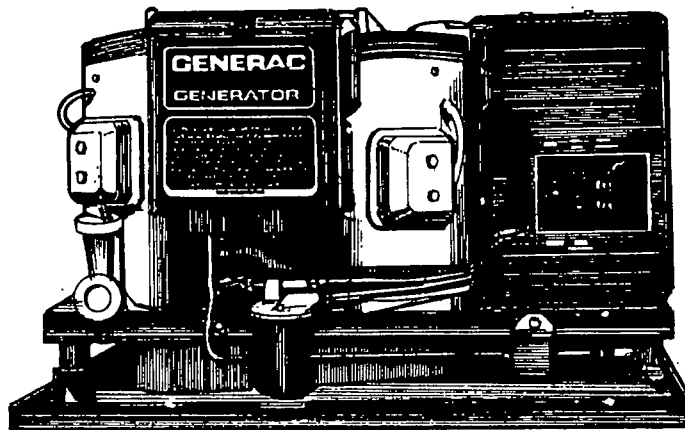

GENERAC

P. O. Box 8
PHONE: (414) 544-4811

Waukesha, WI 53187
FAX: (414) 544-4851

Foreword

PURPOSE OF MANUAL:

This Service Manual has been written and published by Generac Corporation to aid our Dealers' mechanics and company service personnel in the maintenance, servicing, troubleshooting and repair of the products described herein. All information, illustrations and specifications are based on the latest product information available at the time of publication.

Proper service and repair is important to the safe, economical and reliable operation of all recreational vehicle and Industrial mobile generators. Troubleshooting, testing and servicing procedures recommended by Generac and described in this manual are effective methods of performing such operations. Some of these operations or procedures may require the use of specialized equipment. Such equipment should be used when and as recommended.

Generac could not possibly know of and advise the generator service trade of all conceivable procedures by which a service or repair might be performed or of the possible hazards and/or results of each method. We have not undertaken any such wide evaluation. Therefore, anyone who uses a service procedure, method or tool not recommended by Generac must first completely satisfy himself that neither his nor the product's safety will be endangered by the procedure or method selected.

USER'S RESPONSIBILITY:

It is assumed that service personnel are familiar with the servicing procedures of these products or like or similar products manufactured and marketed by Generac. It is further assumed that such personnel have been trained in the recommended servicing procedures for these products; and that such training includes the use of mechanic's common hand tools, special Generac tools, and tools from other suppliers.

SAFETY:

When working on this product, it must be remembered that the generator AC electrical system produces high and dangerous voltages that can cause severe electrical shock. Contact with high voltage terminals, bare wires, etc., can result in dangerous and even fatal injury.

To prevent accidental engine cranking and startup, always disconnect battery cables before working on or around the generator.

Cover all openings into the engine-generator, to prevent entry of foreign materials. Such materials could enter the engine cylinders and cause extensive damage when the engine is started.

It is important to note that the manual contains various DANGER, CAUTION and NOTE blocks. These should be read carefully in order to minimize the risk of personal injury or to prevent methods or practices from being used which could damage equipment or render it unsafe.

FASTENERS:

Replacement fasteners must have the same measurements and strength as the fasteners they will replace. Numbers on the heads of metric bolts and on surfaces of metric nuts indicate their strength. Customary nuts do not have strength markings. Mismatched or incorrect fasteners can cause damage, equipment malfunction or possible injury.

REPLACEMENT PARTS:

Many parts used on recreational vehicle generators and engines are designed and manufactured to comply with rules and regulations established by the Recreational Vehicle Industry Association (RVIA), American National Standards Institute (ANSI), and the National Fire Protection Association (NFPA). Strict compliance with such rules and regulations help to minimize the risk of fire or an explosion. Use of any replacement part that does not comply with such rules and regulations could result in fire or explosion hazard and should be avoided.

APPLICABLE MODELS & SPECIFICATIONS

| MODEL | SERIES | WATTS | VOLTS** | AMPS† | HERTZ | ROTOR RPM | ENGINE RPM | AIR OUTLET | EXHAUST | WIRING DIAGRAM |
|---------|--------|-------|---------|-------|-------|-----------|------------|------------|--------------|----------------|
| 9202-1 | NP | 5200 | 120/240 | 43/22 | 60 | 3600 | 2300 | Bottom out | Bottom out | 89405 |
| 9203-1 | NP | 6600 | 120/240 | 55/27 | 60 | 3600 | 2700 | Bottom out | Bottom out | 89405 |
| 9204-1 | NP | 7200 | 120/240 | 60/30 | 60 | 3600 | 2900 | Bottom out | Bottom out | 89405 |
| 9205-1 | NP | 6600 | 120/240 | 43/22 | 60 | 3600 | 2300 | Bottom out | Out-the-side | 89405 |
| 9206-1 | NP | 6600 | 120/240 | 55/27 | 60 | 3600 | 2700 | Bottom out | Out-the-side | 89405 |
| 9207-1 | NP | 6600 | 120/240 | 55/27 | 60 | 3600 | 2300 | Bottom out | Out-the-side | 89405 |
| 9290-2 | NP | 5000 | 120/240 | 41/20 | 50 | 3000 | 2300 | Bottom out | Bottom out | 93924 |
| 9509-2 | NP | 6600 | 120/240 | 55/27 | 60 | 3600 | 2700 | Bottom out | Out-the-side | 90206 |
| 9592-1 | Q | 5500 | 120/240 | 46/23 | 60 | 3600 | 2570 | Bottom out | Universal | 92116 |
| 9592-2 | Q | 5500 | 120/240 | 46/23 | 60 | 3600 | 2570 | Bottom out | Universal | 92116 |
| 9593-0 | Q | 7000 | 120/240 | 58/29 | 60 | 3600 | 2570 | Bottom out | Universal | 82116 |
| 9593-1 | Q | 7000 | 120/240 | 58/29 | 60 | 3600 | 2570 | Bottom out | Universal | 92116 |
| 9593-2 | Q | 7000 | 120/240 | 58/29 | 60 | 3600 | 2570 | Bottom out | Universal | 92116 |
| 9600-0 | NP | 6600 | 120/240 | 55/27 | 60 | 3600 | 2700 | Bottom out | Universal | 92116 |
| 9600-1 | NP | 6600 | 120/240 | 55/27 | 60 | 3600 | 2700 | Bottom out | Universal | 92116 |
| 9600-2 | NP | 6600 | 120/240 | 55/27 | 60 | 3600 | 2700 | Bottom out | Universal | 92116 |
| 9677-1 | NP | 7200 | 120/240 | 60/30 | 60 | 3600 | 2900 | Bottom out | Universal | 92116 |
| 9677-2 | Q | 7000 | 120/240 | 58/29 | 60 | 3600 | 2570 | Bottom out | Universal | 92116 |
| 9677-3 | Q | 7000 | 120/240 | 58/29 | 60 | 3600 | 2570 | Bottom out | Universal | 92116 |
| 9677-4 | Q | 7000 | 120/240 | 58/29 | 60 | 3600 | 2570 | Bottom out | Universal | 92116 |
| 9712-0‡ | NP | 5000 | 120/240 | 41/20 | 60 | 3600 | 2751 | Bottom out | Universal | 92116 |
| 9712-1‡ | NP | 5000 | 120/240 | 41/20 | 60 | 3600 | 2751 | Bottom out | Universal | 92116 |
| 9734-1* | NP | 6600 | 120/240 | 55/27 | 60 | 3600 | 2700 | Bottom out | Universal | 92116 |
| 9735-1* | Q | 5500 | 120/240 | 46/23 | 60 | 3600 | 2570 | Bottom out | Universal | 92116 |
| 9736-1 | Q | 7000 | 120/240 | 58/29 | 60 | 3600 | 2570 | Bottom out | Universal | 92116 |

* Unit is equipped with an LP Gas fuel system.

** Units are generally shipped from the factory connected for single voltage AC output (120 VAC). However, they can be reconnected for dual voltage AC output (120 and/or 240 VAC).

† Current values listed are at 120 VAC and at 240 VAC (120/240).

‡ Models 9712-0 and 9712-1 are powered by a single cylinder GN-360 engine. All other units are powered by a V-Twin engine.

TABLE OF CONTENTS

Chapter 1- AC GENERATOR FUNDAMENTALS

| | |
|--------------------------------------|--------|
| Magnetism and Electricity | Page 3 |
| Magnetic Induction | Page 3 |
| A Simple AC Generator | Page 3 |
| A More Sophisticated Generator | Page 3 |
| "NP" and "Q" Series Generators | Page 4 |
| Field Boost..... | Page 5 |
| Generator AC Connection System | Page 5 |

Chapter 2- MAJOR GENERATOR COMPONENTS

| | |
|------------------------------------|--------|
| Lower Bearing Carrier | Page 7 |
| Rotor Assembly | Page 7 |
| Stator Assembly..... | Page 7 |
| Upper Bearing Carrier | Page 7 |
| Brush Holder | Page 7 |
| Battery Charge Components..... | Page 8 |
| Excitation Circuit Components..... | Page 8 |

Chapter 3- INSULATION RESISTANCE TESTS

| | |
|------------------------------------|---------|
| Effects of Dirt and Moisture..... | Page 9 |
| Insulation Resistance Testers..... | Page 9 |
| Drying the Generator | Page 9 |
| Cleaning the Generator | Page 9 |
| Stator Insulation Resistance | Page 10 |
| Testing Rotor Insulation | Page 10 |
| The Megohmmeter | Page 11 |

Chapter 4- MEASURING ELECTRICITY

| | |
|------------------------------|---------|
| Meters..... | Page 13 |
| The VOM..... | Page 13 |
| Measuring AC Voltages..... | Page 13 |
| Measuring DC Voltage..... | Page 13 |
| Measuring AC Frequency | Page 13 |
| Measuring Current..... | Page 14 |
| Measuring Resistance..... | Page 14 |

Chapter 5- ENGINE DC CONTROL SYSTEM

| | |
|---------------------------------------|---------|
| Introduction | Page 15 |
| Operational Analysis | Page 15 |
| Engine Controller Circuit Board | Page 16 |
| Battery | Page 17 |
| 15 Amp Fuse..... | Page 17 |
| Fuel Primer Switch..... | Page 18 |
| Start-Stop Switch | Page 18 |
| Starter Contactor & Motor..... | Page 18 |

Chapter 6- TROUBLESHOOTING FLOW CHARTS

| | |
|---|-------------|
| Introduction | Page 19 |
| If Problem Involves AC Generator | Page 19 |
| Problem 1- Voltage & frequency Are Both High or Low | Page 19 |
| Problem 2- Frequency Good But Voltage Low or Residual | Page 19, 20 |
| Problem 3- Frequency and Voltage Both Read Zero..... | Page 20, 21 |
| Problem 4- Excessive Voltage/Frequency Droop When Load Is Applied | Page 21 |
| Problem 5- Priming Function Does Not Work | Page 21 |
| Problem 6- Engine Will Not Crank | Page 22 |
| Problem 7- Engine Cranks But Won't Start | Page 23 |
| Problem 8- Engine Starts Hard and Runs Rough..... | Page 24 |
| Problem 9- Engine Starts and Then Shuts Down | Page 25 |

Chapter 7- DIAGNOSTIC TESTS

| | |
|--|-------------|
| Introduction | Page 27 |
| Test 1- Check No-Load Voltage and Frequency | Page 27 |
| Test 2- Check Engine Governor..... | Page 27-30 |
| Test 3- Fixed Excitation Test..... | Page 30 |
| Test 4- Check Brush Leads | Page 30 |
| Test 5- Test Excitation Circuit Breaker..... | Page 31 |
| Test 6- Test Stator DPE Winding | Page 31, 32 |
| Test 7- Test Brushes & Slip Rings..... | Page 32 |
| Test 8- Check Sensing Leads..... | Page 32 |
| Test 9- Check Field Boost..... | Page 33 |
| Test 10- Check/Adjust Voltage Regulator.. | Page 33, 34 |
| Test 11- Check Rotor Assembly | Page 34 |
| Test 12- Check Stator Power Windings | Page 34, 35 |
| Test 13- Check Main Circuit Breakers..... | Page 35 |
| Test 14- Test Main Circuit Breakers | Page 35 |
| Test 15- Check Load Voltage & Frequency | |
| Test 16- Check Load Watts & Amperage ... | Page 36 |
| Test 17- Check Engine Power | Page 36 |
| Test 18- Try Cranking the Engine | Page 36 |
| Test 19- Test Primer Switch | Page 36 |
| Test 20- Check Fuel Pump..... | Page 37 |
| Test 21- Check 15 Amp Fuse..... | Page 37 |
| Test 22- Check Battery & Cables | Page 37 |
| Test 23- Check Power Supply to Circuit Board | Page 37 |
| Test 24- Check Start-Stop Switch..... | Page 38 |
| Test 25- Check Power Supply to Wire 56... | Page 38 |
| Test 26- Check Starter Contactor | Page 38 |
| Test 27- Check Starter Motor | Page 39 |
| Test 28- Check Fuel Supply..... | Page 39 |
| Test 29- Check Wire 14 Power Supply | Page 39 |
| Test 30- Test Fuel Pump | Page 39 |
| Test 31- Check Fuel Solenoid | Page 39, 40 |
| Test 32- Check Ignition Spark | Page 40 |
| Test 33- Check Spark Plug | Page 40 |
| Test 34- Check Ignition Power Supply | Page 40, 41 |
| Test 35- Test Ignition System..... | Page 41 |
| Test 36- Check Carburetion..... | Page 41 |
| Test 37- Check Choke Operation | Page 42 |
| Test 38- Check Engine | Page 42, 43 |
| Test 39- Check Oil Pressure Switch..... | Page 43, 44 |
| Test 40- Test Oil Temperature Switch | Page 44 |

Chapter 8- ASSEMBLY (V-TWIN ENGINE UNITS)

| | |
|--------------------------------------|---------|
| General..... | Page 45 |
| Sheet Metal | Page 45 |
| Air Cleaner, Carburetor & Choke..... | Page 45 |
| AC Generator..... | Page 45 |
| Control Panel..... | Page 45 |
| Mounting Base and Pulleys..... | Page 45 |

Chapter 9- ASSEMBLY (1-CYLINDER UNITS)

| | |
|---------------------------------------|---------|
| General..... | Page 55 |
| Sheet Metal | Page 55 |
| Air Cleaner, Carburetor & Choke | Page 55 |
| AC Generator..... | Page 55 |
| Control Panel..... | Page 55 |
| Mounting Base and Pulleys..... | Page 55 |

Chapter 10- ELECTRICAL DATA

Chapter One- AC GENERATOR FUNDAMENTALS

Magnetism and Electricity

It has been known for some time that a relationship exists between magnetism and electricity. The "NP" and "Q" series recreational vehicle generators depend on this relationship for their operation. If the service technician is to properly diagnose and repair these units, he must understand this relationship.

Magnetic Induction

When a magnetic field is moved so that its lines of magnetic flux cut across a wire or a coil of wires, an electromotive force or EMF is induced into the wire or coil. The terms "EMF" and "voltage" may be used interchangeably.

If the ends of the wire or coil are connected to form a complete circuit, current will flow through the conductor. The following rules apply:

1. The direction in which the current flows will depend on the polarity of the magnetic field.
2. The amount of voltage induced into the wire depends on the strength of the magnetic field. That is, the stronger or more concentrated the lines of magnetic flux, the greater the voltage.

When current flows through a conductor, a magnetic field is created around the conductor. The strength of the magnetic field depends on (a) the amount of current flow and (b) the number of turns or loops in the conductor. The polarity of the magnetic field depends on the direction of current flow through the wire.

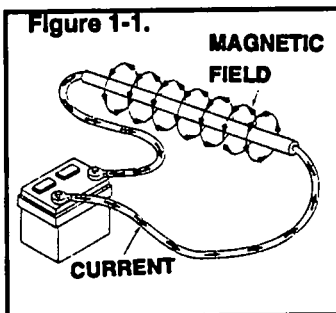

From the above, it is clear that the stronger the magnetic field the greater the voltage induced into the conductor. Additionally, it is apparent that the greater the current flow through the conductor the stronger the magnetic field around that wire. The following rules then apply:

1. If the current flow through a conductor can be regulated, the strength of the magnetic field around the conductor can be regulated.
2. If the strength of the magnetic field can be regulated, the voltage induced by the magnetic field can be regulated.

A Simple AC Generator

Figure 1-2 shows a very simple AC Generator. The generator consists of a rotating magnetic field called a ROTOR and a stationary coil of wire called a STATOR. The ROTOR is a permanent magnet which consists of a SOUTH magnetic pole and a NORTH magnetic pole.

As the ROTOR turns, its magnetic field cuts across the stationary STATOR. A voltage is induced into the STATOR windings. When the magnet's NORTH pole passes the STATOR, current flows in one direction. Current flows in the opposite direction when the magnet's SOUTH pole passes the STATOR. This constant reversal of current flow results in an alternating current (AC)

waveform that can be diagrammed as shown in Figure 1-3.

The ROTOR may be a 2-pole type having a single NORTH and a single SOUTH magnetic pole. Some ROTORS are 4-pole type with two SOUTH and two NORTH magnetic poles. The following apply:

1. The 2-pole ROTOR must be turned at 3600 rpm to produce an AC frequency of 60 Hertz, or at 3000 rpm to deliver an AC frequency of 50 Hertz.
2. The 4-pole ROTOR must operate at 1800 rpm to deliver a 60 Hertz AC frequency or at 1500 rpm to deliver a 50 Hertz AC frequency.

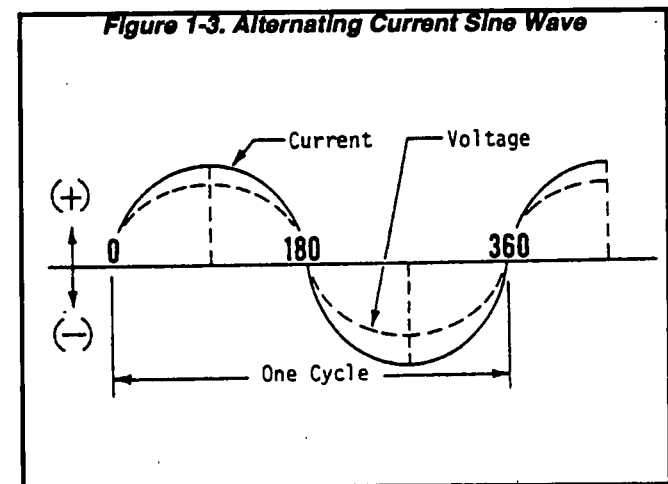
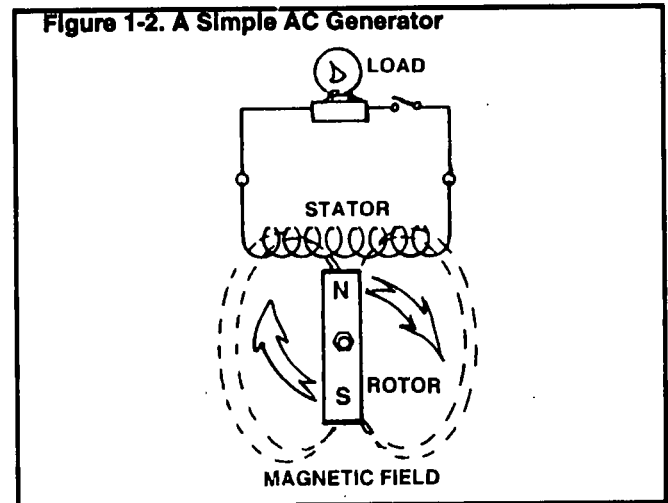

A More Sophisticated AC Generator

Figure 1-4 (next page) represents a more sophisticated generator. A regulated direct current is delivered into the ROTOR windings via carbon BRUSHES AND SLIP RINGS. This results in the creation of a regulated magnetic field around the ROTOR. As a result, a regulated voltage is induced into the STATOR. Regulated current delivered to the ROTOR is called "EXCITATION" current.

Chapter One- AC GENERATOR FUNDAMENTALS

A More Sophisticated Generator (Continued)

NOTE: AC output frequency at 3720 rpm will be about 62 Hertz. The "No-Load" speed is set slightly high to prevent excessive rpm, frequency and voltage droop under heavy electrical loading.

Figure 1-4. A More Sophisticated Generator

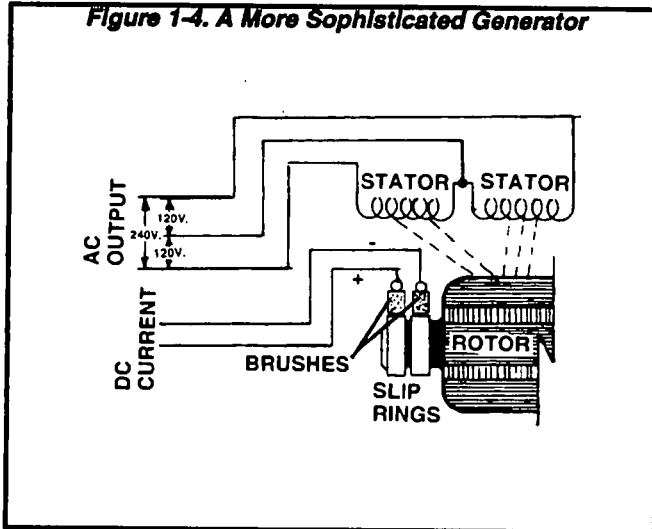

Generator operation may be described briefly as follows:

1. Some "residual" magnetism is normally present in the Rotor and is sufficient to induce approximately 7 to 12 volts AC into the STATOR's AC power windings.
2. During startup, an engine controller circuit board delivers battery voltage to the ROTOR, via the brushes and slip rings.
 - a. The battery voltage is called "Field Boost".
 - b. Flow of direct current through the ROTOR increases the strength of the magnetic field above that of "residual" magnetism alone.
3. "Residual" plus "Field Boost" magnetism induces a voltage into the Stator excitation (DPE), battery charge and AC Power windings.
4. Excitation winding unregulated AC output is delivered to an electronic voltage regulator, via an excitation circuit breaker.
 - a. A "Reference" voltage has been preset into the Voltage Regulator.
 - b. An "Actual" ("sensing") voltage is delivered to the Voltage Regulator via sensing leads from the Stator AC power windings.
 - c. The Regulator "compares" the actual (sensing) voltage to its pre-set reference voltage.

"NP" and "Q" Series Generators

See Figure 1-5 below. The revolving magnetic field (ROTOR) is driven by the engine at a constant speed, through a pulley and v-belt arrangement. This constant speed is maintained by a mechanical engine governor. Units with 2-pole Rotor require an operating speed of 3600 rpm to deliver a 60 Hertz AC output. Engine governors are set to maintain approximately 3720 rpm when no electrical loads are connected to the generator.

Figure 1-5. Operating Diagram- "NP" and "Q" Series Generators

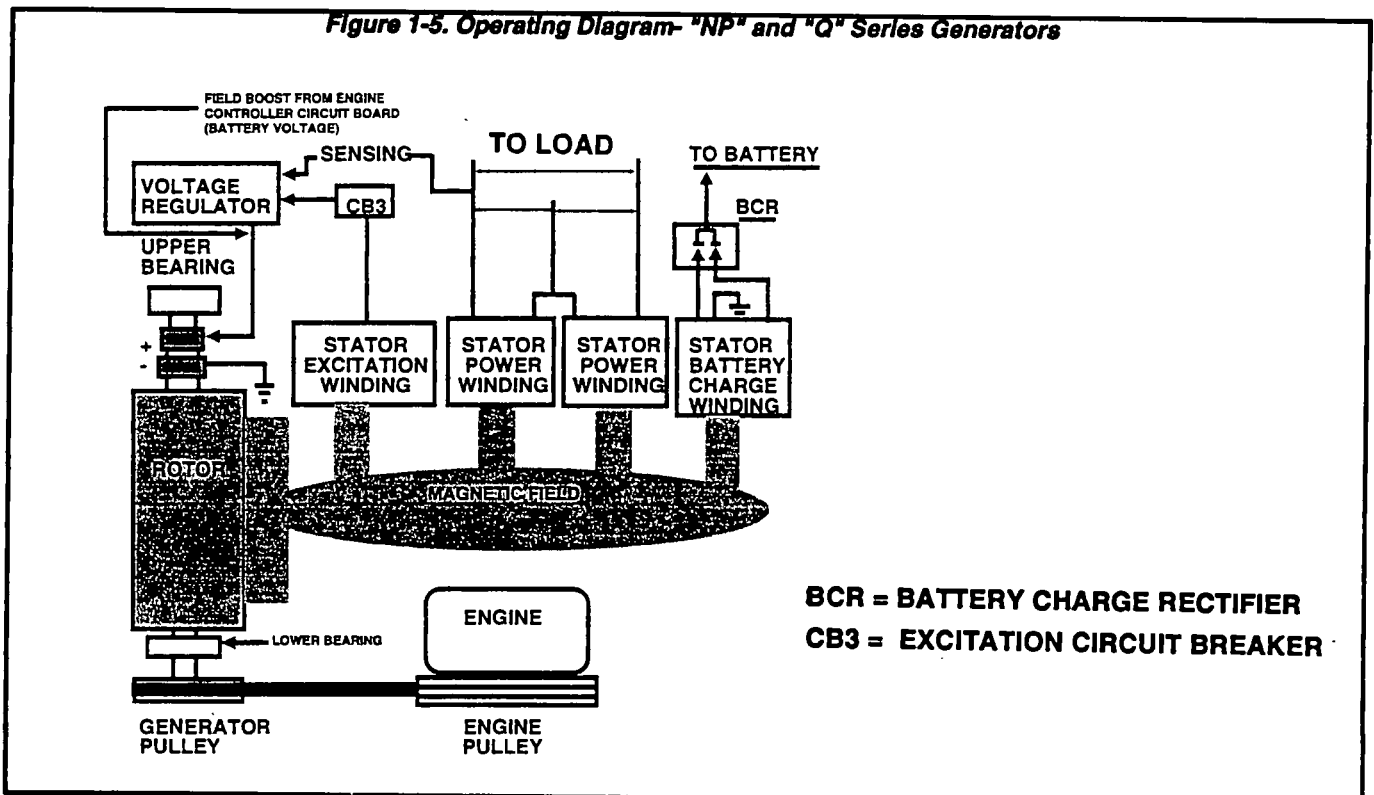

BCR = BATTERY CHARGE RECTIFIER
CB3 = EXCITATION CIRCUIT BREAKER

Chapter One- AC GENERATOR FUNDAMENTALS

- (1) If the actual (sensing) voltage is greater than the pre-set reference voltage, the Regulator will decrease the regulated current flow to the Rotor.
- (2) If the actual (sensing) voltage is less than the pre-set reference voltage, the Regulator will increase the regulated current flow to the Rotor.
- (3) In the manner described, the Regulator maintains an actual (sensing) voltage that is equal to the pre-set reference voltage.

NOTE: The Voltage Regulator also changes the Stator excitation winding's alternating current (AC) output to direct current (DC).

5. When an electrical load is connected across the Stator power windings, the circuit is completed and an electrical current will flow.

6. The Rotor's magnetic field also induces a voltage into the Stator battery charge windings.

- a. Battery charge winding AC output is delivered to a battery charge rectifier (BCR) which changes the AC to direct current (DC).
- b. The rectified DC is then delivered to the unit battery, to maintain the battery in a charged state.
- c. A 1 ohm, 25 watt Resistor is installed in series with the grounded side of the battery charge circuit.

Field Boost

When the engine is cranked during startup, the engine's starter contactor is energized closed. Battery current is then delivered to the starter motor and the engine cranks.

Closure of the starter contactor contacts also delivers battery voltage to Terminal 13 of an Engine Controller circuit board. The battery current flows through a 47 ohm, 2 watt resistor and a field boost diode, then to the Rotor via brushes and slip rings. This is called "Field Boost" current.

Field boost current is delivered to the Rotor only while the engine is cranking. The effect is to "flash the field" every time the engine is cranked. Field boost current helps ensure that sufficient "pickup" voltage is available on every startup to turn the Voltage Regulator on and build AC output voltage.

NOTE: Loss of the Field Boost function may or may not result in loss of AC power winding output. If Rotor residual magnetism alone is sufficient to turn the Regulator on, loss of Field Boost may go unnoticed. However, if residual magnetism alone is not enough to turn the Regulator on, loss of the Field Boost function will result in loss of AC power winding output to the load. The AC output voltage will then drop to a value commensurate with the Rotor's residual magnetism (about 7-12 VAC).

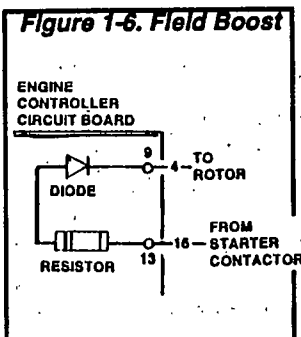

Generator AC Connection System

GENERAL:

The Stator AC power winding consists of two windings, with each winding capable of supplying 120 volts AC. When the two windings are connected in series, a 240 volts AC output results. In most cases, units are shipped from the factory connected for 120 volts AC output only.

CONNECTIONS FOR SINGLE VOLTAGE OUTPUT:

Figure 1-7 shows the system connected for 120 volts AC output only. Some models are equipped with a 30 amp and a 20 amp main circuit breaker, others may be equipped with two 30 amp circuit breakers.

RECONNECTION FOR DUAL VOLTAGE OUTPUT:

When reconnected for dual voltage output, Stator output leads 11P and 44 form the two "hot" leads (T1- Red and T3- Black). The junction of leads 22P and 33 form the "Neutral" line (T2- White).

For dual voltage output, the "Neutral" line remains grounded. However, the jumper wire between the two main circuit breakers has been removed.

NOTE: For units with two 30 amp main breakers, the existing breakers may be re-used when reconnecting for dual voltage output. However, on units with a 30 amp and a 20 amp main breaker, you may wish to install a 2-pole breaker that is rated closer to the unit's rated capacity.

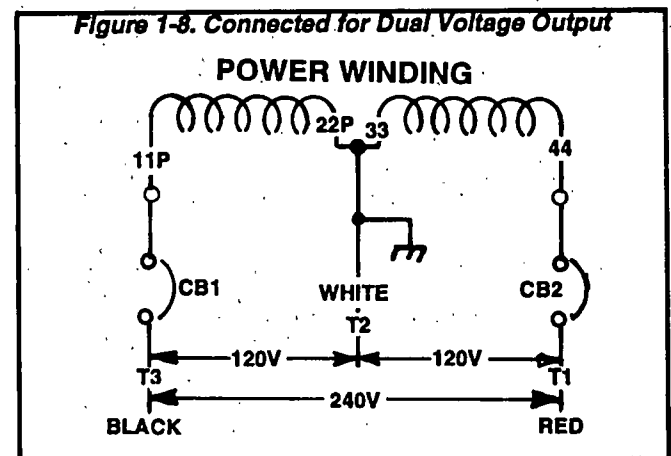
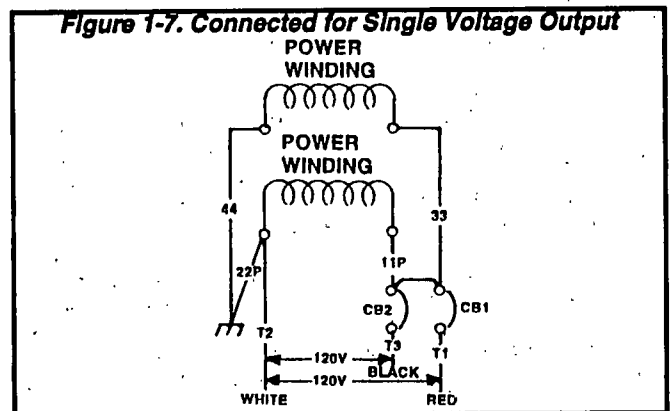

Chapter One- AC GENERATOR FUNDAMENTALS

Chapter Two- MAJOR GENERATOR COMPONENTS

Figure 2-1. Exploded View of Generator

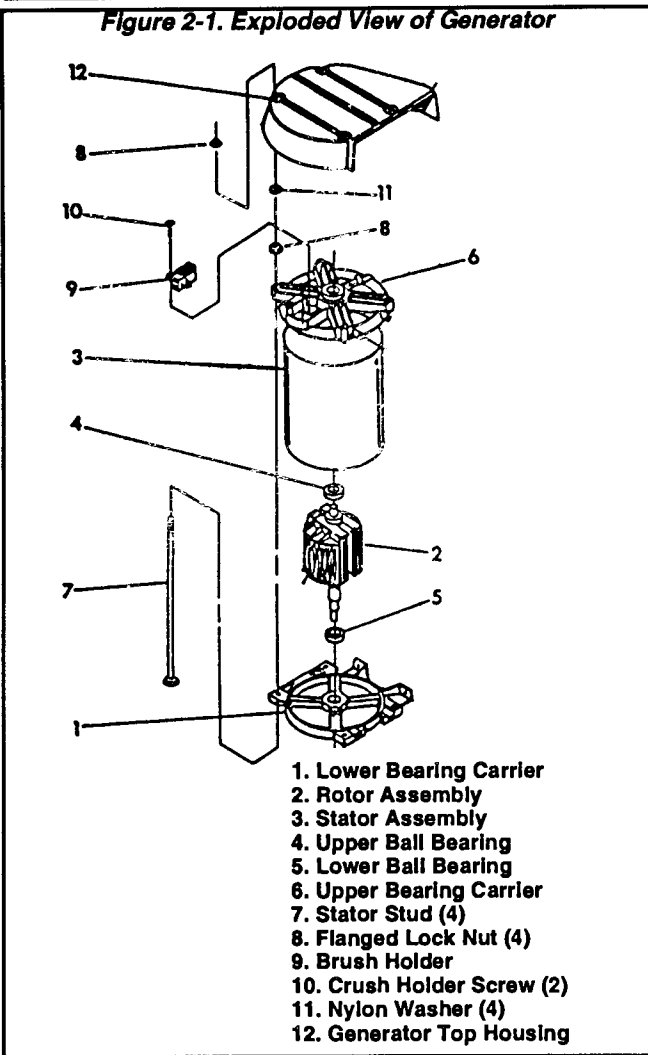

Lower Bearing Carrier

The lower bearing carrier supports the vertically mounted Stator and the lower Rotor bearing. Bosses are located around the carrier's outer periphery to accept the four Stator bolts.

Rotor Assembly

The Rotor is sometimes called the "revolving field", since it provides the magnetic field that induces a voltage into the stationary Stator windings. It is supported by two ball bearings, one in the lower and one in the upper bearing carrier. Slip rings on the upper Rotor shaft allow excitation current from the voltage regulator to be delivered to the Rotor windings. A pulley is keyed and retained to the lower Rotor shaft, allowing the Rotor to be driven by the engine via a drive belt.

All generator models in this manual utilize a 2-pole Rotor, i.e., one having a single north and a single south pole. This type of Rotor must be driven at 3600 rpm for a 60 Hertz AC output; or at 3000 rpm for a 50 Hertz output.

Slip rings may be cleaned. If dull or tarnished, clean them with fine sandpaper. **DO NOT USE ANY METALLIC GRIT OR ABRASIVE TO CLEAN SLIP RINGS.**

Stator Assembly

The Stator is "sandwiched" between the upper and lower bearing carriers and retained in that position by four Stator studs. Windings included in the Stator assembly are (a) dual AC power windings, (b) an excitation or DPE winding, and (c) a battery charge winding. A total of eleven (11) leads are brought out of the Stator as follows:

1. Four (4) Stator power winding output leads (Wires No. 11P, 22P, 33 and 44). These leads deliver power to connected electrical loads.
2. Stator Power winding "sensing" leads (11S and 22S). These leads deliver an "actual" voltage signal to the electronic Voltage Regulator.
3. Two excitation winding output leads (No. 2 and 6). These leads deliver unregulated excitation current to the voltage regulator.
4. Three (3) battery charge output leads (No. 55, 66 and 77).

Figure 2-2. Stator Output Leads

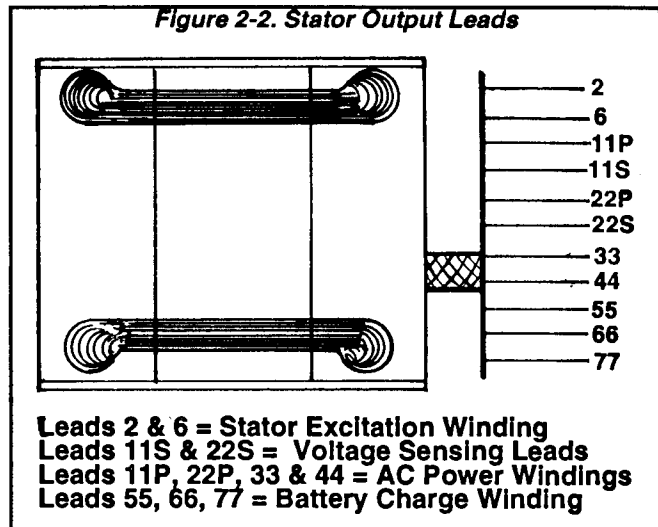

Upper Bearing Carrier

The upper bearing carrier supports the Stator. It also provides mounting for a Brush Holder and a top housing. The Rotor's upper ball bearing is supported in the upper bearing carrier.

Brush Holder

Figure 2-3.

The brush holder is retained in the upper bearing carrier by two M5 screws. It retains two brushes which contact the Rotor slip rings and allow current flow from stationary parts to the revolving Rotor. The positive (+) brush is located nearest the Rotor bearing.

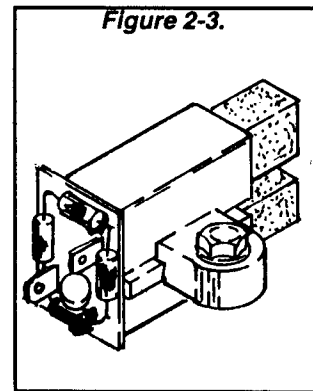

Chapter Two- MAJOR GENERATOR COMPONENTS

Battery Charge Components

The Stator incorporates dual battery charge windings. A battery charge rectifier (BCR) changes the AC output of these windings to direct current (DC). Battery charge winding output is delivered to the unit battery via the rectifier, a 15 amp fuse and Wire No. 13. A 1 ohm, 25 watt resistor is connected in series with the grounded side of the circuit.

Figure 2-4. Battery Charge Circuit

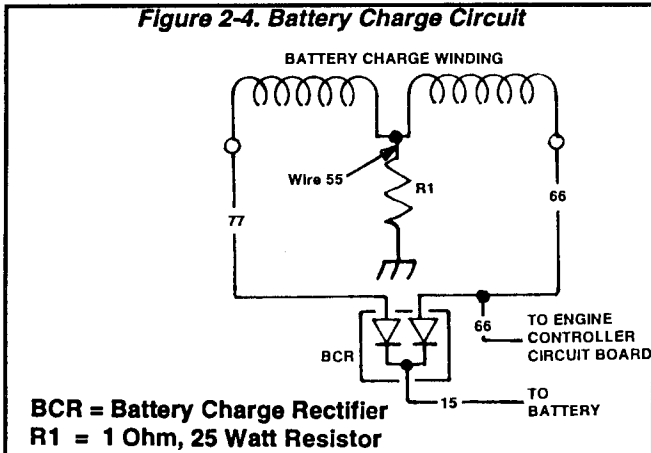

Excitation Circuit Components

GENERAL:

During operation, the Rotor's magnetic field induces a voltage and current flow into the Stator excitation winding. The resultant AC output is delivered to a voltage regulator via an excitation circuit breaker (CB3).

Figure 2-5. Schematic- Excitation Circuit

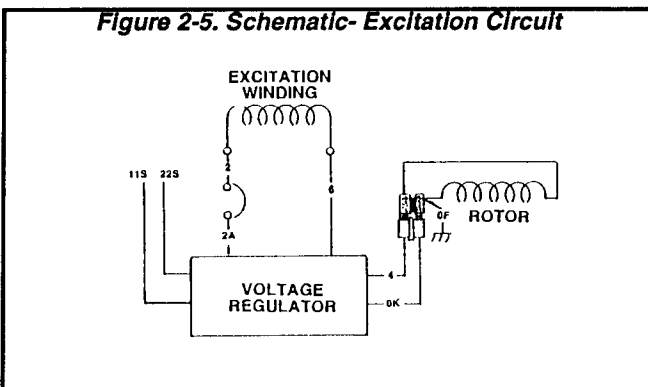

EXCITATION CIRCUIT BREAKER:

The excitation circuit breaker (CB3) is self-resetting and cannot be reset manually. Should the breaker open for any reason, excitation current flow to the Rotor will be lost. The unit's AC output voltage will then drop to a value commensurate with the Rotor's residual magnetism (about 7-12 VAC).

Figure 2-6.

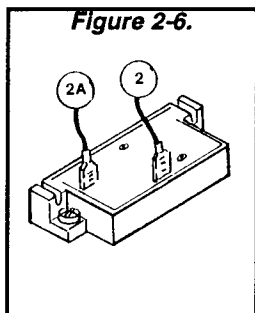

VOLTAGE REGULATOR:

Six (6) leads are connected to the voltage regulator as follows:

- Two (2) SENSING leads deliver ACTUAL AC output voltage signals to the regulator. These are Wires No. 11S and 22S.
- Two (2) leads (No. 2 and 6) deliver Stator excitation winding AC output to the regulator.
- Two (2) leads (1 and 4) deliver the regulated direct current to the Rotor, via brushes and slip rings.

The regulator mounts a "VOLTAGE ADJUST" potentiometer, used for adjustment of the pre-set REFERENCE voltage. A lamp (LED) will turn on to indicate that SENSING (actual) voltage is available to the regulator and the regulator is turned on.

NOTE: If, for any reason, sensing voltage to the regulator is lost, the regulator will shut down and excitation output to the Rotor will be lost. The AC output voltage will then drop to a value that is commensurate with Rotor residual magnetism (about 7-12 VAC). Without this automatic shutdown feature, loss of sensing (actual) voltage to the regulator would result in a "full field" or "full excitation" condition and an extremely high AC output voltage.

Figure 2-7. Voltage Regulator

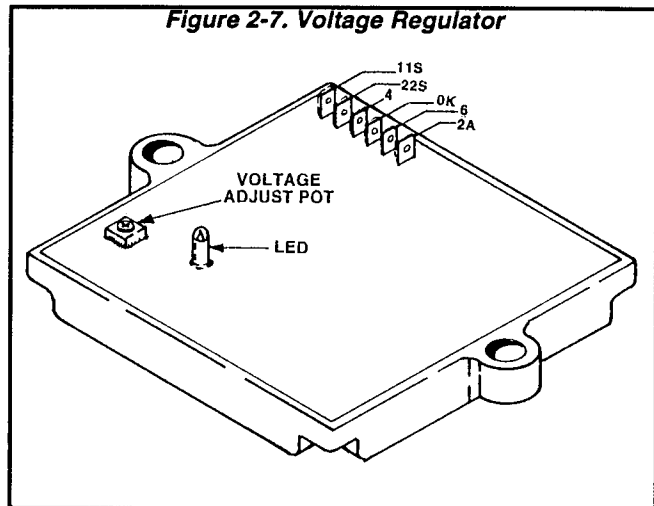

NOTE: Adjustment of the regulator's "VOLTAGE ADJUST" potentiometer must be done only when the unit is running at its correct governed no-load speed. Speed is correct when the unit's no-load AC output frequency is about 61-63 Hertz. At the stated frequency, AC output voltage should be about 122-126 volts.

Chapter Three- INSULATION RESISTANCE TESTS

Effects of Dirt and Moisture

Moisture and dirt are detrimental to the continued good operation of any generator set.

If moisture is allowed to remain in contact with the Stator and Rotor windings, some of the moisture will be retained in voids and cracks of the winding insulation. This will result in a reduced insulation resistance and, eventually, the unit's AC output will be affected.

Insulation used in NP and Q-Series generators is moisture resistant. However, prolonged exposure to moisture will gradually reduce the resistance of the winding insulation.

Dirt can make the problem worse, since it tends to hold moisture into contact with the windings. Salt, as from sea air, also worsens the problem since salt can absorb moisture from the air. When salt and moisture combine, they make a good electrical conductor.

Because of the detrimental effects of dirt and moisture, the generator should be kept as clean and as dry as possible. Rotor and Stator windings should be tested periodically with an insulation resistance tester (such as a megohmmeter or hi-pot tester).

If the insulation resistance is excessively low, drying may be required to remove accumulated moisture. After drying, perform a second insulation resistance test. If resistance is still low after drying, replacement of the defective Rotor or Stator may be required.

Insulation Resistance Testers

Figure 3-1 shows one kind of hi-pot tester. The tester shown has a "Breakdown" lamp that will glow during the test procedure to indicate an insulation breakdown in the winding being tested.

DANGER!
INSULATION RESISTANCE TESTERS SUCH AS HI-POT TESTERS AND MEGOHMMETERS ARE A SOURCE OF HIGH AND DANGEROUS ELECTRICAL VOLTAGE. FOLLOW THE TESTER MANUFACTURER'S INSTRUCTIONS CAREFULLY. USE COMMON SENSE TO AVOID DANGEROUS ELECTRICAL SHOCK.

Figure 3-1. One Type of Hi-Pot Tester

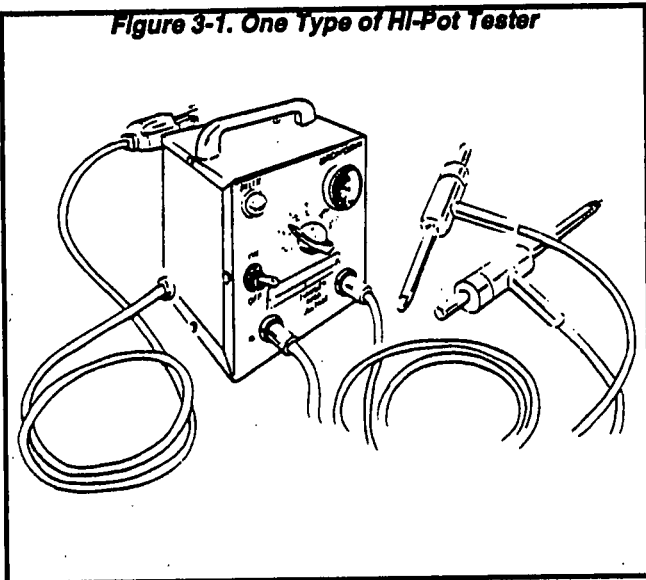

Drying the Generator

GENERAL:

If tests indicate the insulation resistance of a winding is below a safe value, the winding should be dried before operating the generator. Some recommended drying procedures include (a) heating units and (b) forced air.

HEATING UNITS:

If drying is needed, the generator can be enclosed in a covering. Heating units can then be installed to raise the temperature about 15°-18° F. (8°-10° C.) above ambient temperature.

FORCED AIR:

Portable forced air heaters can be used to dry the generator. Direct the heated air into the generator's air intake openings. Remove the voltage regulator and run the unit at no-load. Air temperature at the point of entry into the generator should not exceed 150° F. (66° C.).

Cleaning the Generator

GENERAL:

The generator can be cleaned properly only while it is disassembled. The cleaning method used should be determined by the type of dirt to be removed. Be sure to dry the unit after it has been cleaned.

NOTE: A shop that repairs electric motors may be able to assist you with the proper cleaning of generator windings. Such shops are often experienced in special problems such as a sea coast environment, marine or wetland applications, mining, etc.

USING SOLVENTS FOR CLEANING:

If dirt contains oil or grease, a solvent is generally required. Only petroleum distillates should be used to clean electrical components. Recommended are safety type petroleum solvents having a flash point greater than 100° F. (38° C.).

Use a soft brush or cloth to apply the solvent. Be careful to avoid damage to magnet wire or winding insulation. After cleaning, dry all components thoroughly using moisture-free, low-pressure compressed air.

DANGER!
DO NOT ATTEMPT TO WORK WITH SOLVENTS IN ANY ENCLOSED AREA. PROVIDE ADEQUATE VENTILATION WHEN WORKING WITH SOLVENTS. WITHOUT ADEQUATE VENTILATION, FIRE, EXPLOSION OR HEALTH HAZARDS MAY EXIST. WEAR EYE PROTECTION. WEAR RUBBER GLOVES TO PROTECT THE HANDS.

CAUTION!
Some generators may use epoxy or polyester base winding varnishes. Use solvents that will not attack such materials.

CLOTH OR COMPRESSED AIR:

For small parts or when dry dirt is to be removed, a dry cloth may be satisfactory. Wipe the parts clean, then use low pressure air at 30 psi (206 Kpa) to blow dust away.

Chapter Three- INSULATION RESISTANCE TESTS

Cleaning the Generator (Continued)

BRUSHING AND VACUUM CLEANING:

Brushing with a soft bristle brush followed by vacuum cleaning is a good method of removing dust and dirt. Use the soft brush to loosen the dirt, then remove it with the vacuum.

Stator Insulation Resistance

GENERAL:

Insulation resistance is a measure of the integrity of the insulating materials that separate electrical windings from the generator's steel core. This resistance can degrade over time due to the presence of contaminants (dust, dirt, grease and especially moisture).

The normal insulation resistance for generator windings is on the order of "millions of ohms" or "megohms".

When checking the insulation resistance, follow the tester manufacturer's instructions carefully. Do NOT exceed the applied voltages recommended in this manual. Do NOT apply the voltage longer than one (1) second.

CAUTION!

DO NOT connect the HI-Pot Tester or Megohmmeter test leads to any leads that are routed into the generator control panel. Connect the tester leads to the Stator or Rotor leads only.

STATOR SHORT-TO-GROUND TESTS:

See Figure 3-2. To test the Stator for a short-to-ground condition, proceed as follows:

1. Disconnect and isolate all Stator leads as follows:
 - a. Disconnect sensing leads 11S and 22S from the voltage regulator.
 - b. Disconnect excitation winding lead No. 6 from the voltage regulator.
 - c. Disconnect excitation lead No. 2 from the excitation circuit breaker (CB3).
 - d. Disconnect battery charge winding leads No. 66 and 77 from the battery charge rectifier (BCR).
 - e. Disconnect battery charge winding lead No. 55 from the battery charge circuit resistor (R1).
 - f. At the main circuit breakers, disconnect AC power leads No. 11P and 33.
 - g. At the 4-tab ground terminal (GT), disconnect Stator power leads No. 22P and 44.
2. When all leads have been disconnected as outlined in Step 1 above, test for a short-to-ground condition as follows:
 - a. Connect the terminal ends of all Stator leads together (11S, 22S, 11P, 22P, 33, 44, 2, 6, 55, 66, 77).
 - b. Follow the tester manufacturer's instructions carefully. Connect the tester leads across all Stator leads and to frame ground on the Stator can. Apply a voltage of 1500 volts. Do NOT apply voltage longer than one (1) second.

If the test indicates a breakdown in insulation, the Stator should be cleaned, dried and re-tested. If the winding fails the second test (after cleaning and drying), replace the Stator assembly.

TEST BETWEEN ISOLATED WINDINGS:

1. Follow the tester manufacturer's instructions carefully. Connect the tester test leads across Stator leads No. 11 and 2. Apply a voltage of 1500 volts- DO NOT EXCEED 1 SECOND.

2. Repeat Step 1 with the tester leads connected across the following Stator leads:

- a. Across Wires No. 33 and 2.
- b. Across Wires No. 11 and 66.
- c. Across Wires No. 33 and 66.
- d. Across Wires No. 2 and 66.

If a breakdown in the insulation between isolated windings is indicated, clean and dry the Stator. Then, repeat the test. If the Stator fails the second test, replace the Stator assembly.

TEST BETWEEN PARALLEL WINDINGS:

Connect the tester leads across Stator leads No. 11 and 33. Apply a voltage of 1500 volts. If an insulation breakdown is indicated, clean and dry the Stator. Then, repeat the test between parallel windings. If the Stator fails the second test, replace it.

Figure 3-2. Stator Leads

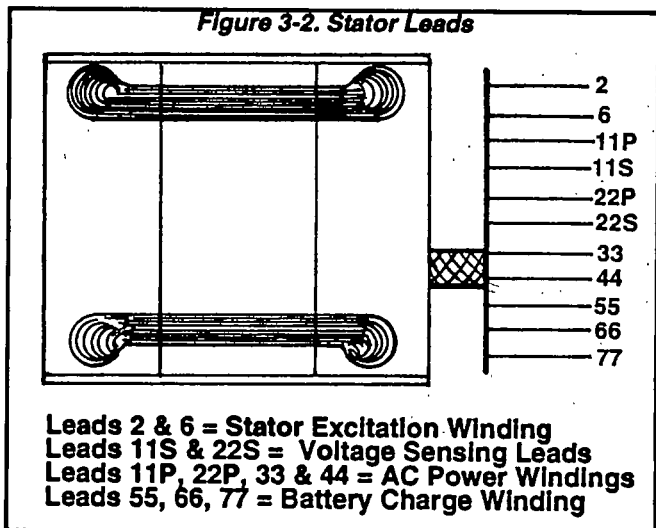

Testing Rotor Insulation

To test the Rotor for insulation breakdown, proceed as follows:

1. Disconnect wires from the Rotor brushes or remove the brush holders with brushes.
2. Connect the tester positive (+) test lead to the positive (+) slip ring (nearest the Rotor bearing). Connect the tester negative (-) test lead to a clean frame ground (like the Rotor shaft).
3. Apply 1000 volts. DO NOT APPLY VOLTAGE LONGER THAN 1 SECOND.

If an insulation breakdown is indicated, clean and dry the Rotor then repeat the test. Replace the Rotor if it fails the second test (after cleaning and drying).

Chapter Three- INSULATION RESISTANCE TESTS

Figure 3-3. Rotor Test Points

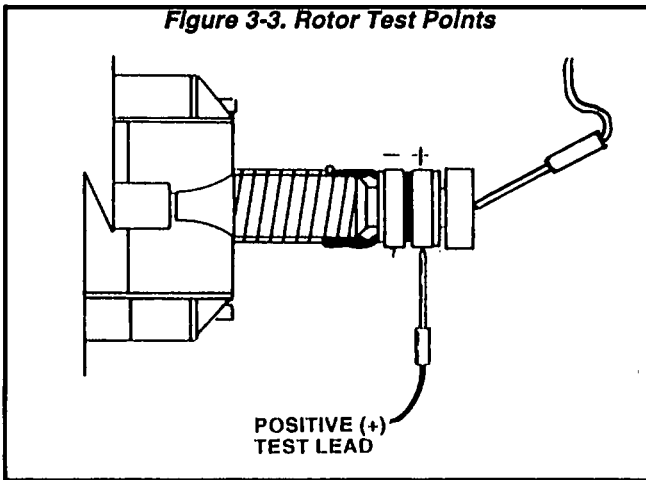

The Megohmmeter

GENERAL:

A megohmmeter, often called a "megger", consists of a meter calibrated in megohms and a power supply. Use a power supply of 1500 volts when testing Stators; or 1000 volts when testing the Rotor. **DO NOT APPLY VOLTAGE LONGER THAN ONE (1) SECOND.**

TESTING STATOR INSULATION:

All parts that might be damaged by the high megger voltages must be disconnected before testing. Isolate all Stator leads (Figure 3-2) and connect all of the Stator leads together. **FOLLOW THE MEGGER MANUFACTURER'S INSTRUCTIONS CAREFULLY.**

Use a megger power setting of 1500 volts. Connect one megger test lead to the junction of all Stator leads, the other test lead to frame ground on the Stator can. Read the number of megohms on the meter.

The **MINIMUM** acceptable megger reading for Stators may be calculated using the following formula:

| | | | |
|---|---|-----------------------|----|
| MINIMUM INSULATION RESISTANCE (in "Megohms") | = | GENERATOR RATED VOLTS | +1 |
| | | 1000 | |

EXAMPLE: Generator is rated at 240 volts AC. Divide "240" by "1000" to obtain "0.24". Then, add "1" to obtain "1.24" megohms. Minimum insulation resistance for a 240 VAC Stator is 1.24 megohms.

If the Stator insulation resistance is less than the calculated minimum resistance, clean and dry the Stator. Then, repeat the test. If resistance is still low, replace the Stator.

Use the Megger to test for shorts between isolated windings as outlined "Stator Insulation Resistance".

Also test between parallel windings. See "Test Between Parallel Windings" on Page 10.

TESTING ROTOR INSULATION:

Apply a voltage of 1000 volts across the Rotor slip rings. **DO NOT EXCEED 1000 VOLTS AND DO NOT APPLY VOLTAGE LONGER THAN 1 SECOND. FOLLOW THE MEGGER MANUFACTURER'S INSTRUCTIONS CAREFULLY.**

| |
|---|
| <p>ROTOR MINIMUM INSULATION RESISTANCE 1.5 megohms</p> |
|---|

Chapter Three- INSULATION RESISTANCE TESTS

Chapter Four- MEASURING ELECTRICITY

Meters

Devices used to measure electrical properties are called meters. Meters are available that allow one to measure (a) AC voltage, (b) DC voltage, (c) AC frequency, and (d) resistance in ohms. The following apply:

- To measure AC voltage, use an AC voltmeter.
- To measure DC voltage, use a DC voltmeter.
- Use a frequency meter to measure AC frequency in "Hertz" or "cycles per second"...
- Use an ohmmeter to read circuit resistance, in "ohms".

The VOM

A meter that will permit both voltage and resistance to be read is the "volt-ohm-milliammeter" or "VOM".

Some VOM's are of the "analog" type (Figure 4-1). These meters display the value being measured by physically deflecting a needle across a graduated scale. The scale used must be interpreted by the user.

"Digital" VOM's (Figure 4-1) are also available and are generally very accurate. Digital meters display the measured values directly by converting the values to numbers.

NOTE: Standard AC voltmeters react to the AVERAGE value of alternating current. When working with AC, the effective or "rms" value is used. For that reason, a different scale is used on an AC voltmeter. The scale is marked with the effective or "rms" value even though the meter actually reacts to the average value. That is why the AC voltmeter will give an incorrect reading is used to measure direct current (DC).

Figure 4-1. Analog and Digital VOM's

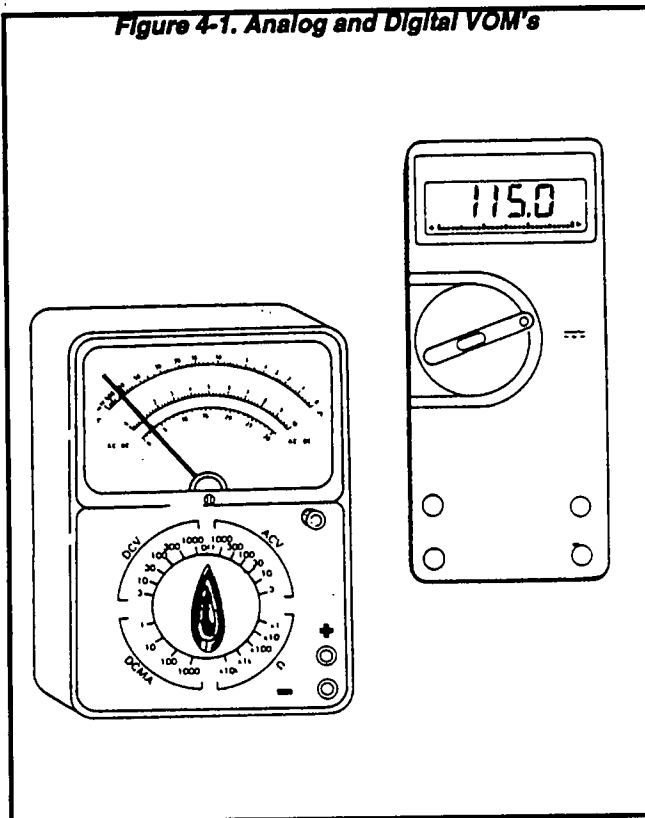

Measuring AC Voltages

An accurate AC voltmeter or a VOM may be used to read the generator's AC output voltage. The following apply:

1. Always read the generator's AC output voltage only at the unit's rated operating speed and AC frequency.
2. The generator's voltage regulator can be adjusted for correct output voltage only while the unit is operating at its correct rated speed and frequency.
3. Only an AC voltmeter may be used to measure AC voltage. **DO NOT USE A DC VOLTMETER FOR THIS PURPOSE.**

DANGER!

RV GENERATORS PRODUCE HIGH AND DANGEROUS VOLTAGES. CONTACT WITH HIGH VOLTAGE TERMINALS WILL RESULT IN DANGEROUS AND POSSIBLY LETHAL ELECTRICAL SHOCK.

Measuring DC Voltage

A DC voltmeter or a VOM may be used to measure DC voltages. Always observe the following rules:

1. Always observe correct DC polarity.
 - a. Some VOM's may be equipped with a polarity switch.
 - b. On meters that do not have a polarity switch, DC polarity must be reversed by reversing the test leads.
2. Before reading a DC voltage, always set the meter to a higher voltage scale than the anticipated reading. If in doubt, start at the highest scale and adjust the scale downward until correct readings are obtained.
3. The design of some meters is based on the "current flow" theory while others are based on the "electron flow" theory.
 - a. The "current flow" theory assumes that direct current flows from the positive (+) to the negative (-).
 - b. The "electron flow" theory assumes that current flows from negative (-) to positive (+).

NOTE: When testing NP and Q-Series generators, the "current flow" theory is applied. That is, current is assumed to flow from positive (+) to negative (-).

Measuring AC Frequency

The generator's AC output frequency is proportional to Rotor speed. Generators equipped with a 2-pole Rotor must operate at 3600 rpm to supply a frequency of 60 Hertz. Units with 4-pole Rotor must run at 1800 rpm to deliver 60 Hertz.

NOTE: "NP" and "Q-Series" Rotors are engine driven through a drive belt and pulley arrangement. Drive ratios may differ between models.

Correct engine and Rotor speed is maintained by an engine speed governor. For models rated 60 Hertz, the governor is generally set to maintain a no-load frequency of about 62 Hertz with a corresponding output voltage of about 124 volts AC line-to-neutral; or 248 volts line-to-line. Engine speed and frequency at no-load are set slightly high to prevent excessive rpm and frequency drop under heavy electrical loading.

Chapter Four- MEASURING ELECTRICITY

Measuring Current

To read the current flow, in AMPERES, a clamp-on ammeter may be used. This type of meter indicates current flow through a conductor by measuring the strength of the magnetic field around that conductor. The meter consists essentially of a current transformer with a split core and a rectifier-type instrument connected to the secondary. The primary of the current transformer is the conductor through which the current to be measured flows. The split core allows the instrument to be clamped around the conductor without disconnecting it.

Current flowing through a conductor may be measured safely and easily. A line-splitter can be used to measure current in a cord without separating the conductors.

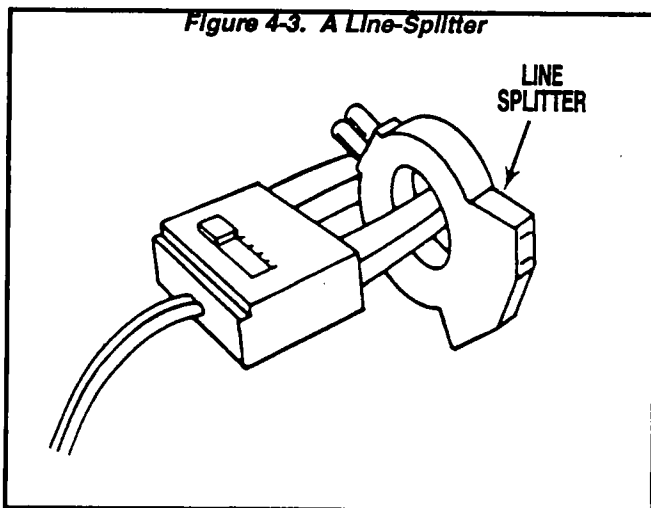
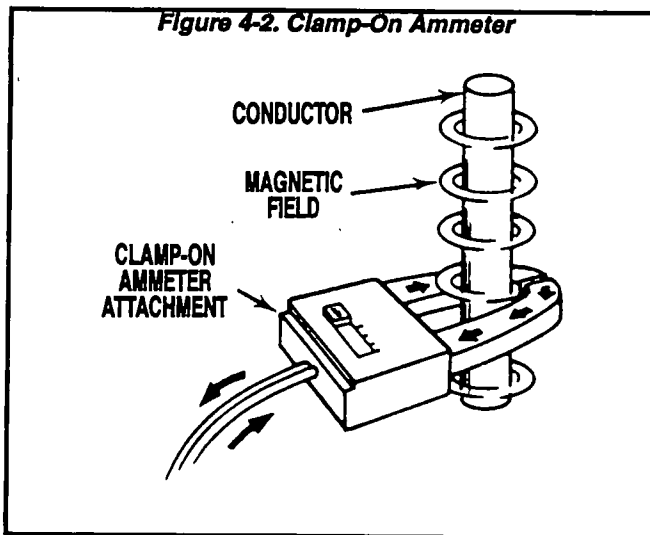

NOTE: If the physical size of the conductor or ammeter capacity does not permit all lines to be measured simultaneously, measure current flow in each individual line. Then, add the individual readings.

Measuring Resistance

The volt-ohm-milliammeter may be used to measure the resistance in a circuit. Resistance values can be very valuable when testing coils or windings, such as the Stator and Rotor windings.

When testing Stator windings, keep in mind that the resistance of these windings is very low. Some meters are not capable of reading such a low resistance and will simply read "continuity".

If proper procedures are used, the following conditions can be detected using a VOM:

- A "short-to-ground" condition in any Stator or Rotor winding.
- Shorting together of any two parallel Stator windings.
- Shorting together of any two isolated Stator windings.
- An open condition in any Stator or Rotor winding.

Chapter Five- ENGINE DC CONTROL SYSTEM

Introduction

The engine DC control system includes all components necessary to the operation of the engine. Operation includes cranking, starting, running and shutdown. The system is shown schematically in Figure 5-2.

Operational Analysis

CIRCUIT CONDITION- SHUTDOWN:

Battery voltage is available to the engine controller circuit board (PCB) from the unit BATTERY and via (a) the RED battery cable, Wire 13, a 15 amp FUASE (F1), Wire 15 and circuit board Terminal J3. However, circuit board action is holding the circuit open and no action can occur.

Battery output is available to the contacts of a STARTER CONTACTOR (SC), but the contacts are open.

Battery voltage is also delivered to the FUEL PRIMER SWITCH (SW2). The switch is open and the circuit is incomplete.

CIRCUIT CONDITION- PRIMING:

When the FUEL PRIMER SWITCH (DW2) is closed by the operator, battery voltage is delivered across the closed switch contacts and to the FUEL PUMP (FP) via Wire 14A. If the unit is equipped with a FUEL SOLENOID (FS), it will be energized via Wire 14.

CIRCUIT CONDITION- CRANKING:

When the START-STOP SWITCH (SW1) is held at "START" position, Wire 17 from the engine controller circuit board is connected to frame ground. Circuit board action will then deliver battery voltage to (a) a STARTER CONTACTOR (SC) via Wire 56, and to an automatic CHOKE SOLENOID (CS) via Wire 90.

When battery voltage energizes the STARTER CONTACTOR (SC), its contacts close and battery output is delivered to the STARTER MOTOR (SM) via Wire 16. The STARTER MOTOR (SM) energizes and the engine cranks.

| Legend for Figure 5-1 | |
|-----------------------|-------------------------------------|
| BCR | Battery Charge Rectifier |
| CH | Choke Heater |
| CS | Choke Solenoid |
| CS | Choke Isolation Switch (MP-50 Only) |
| F1 | 15 amp Fuse |
| FP | Fuel Pump (or LPG Shutoff Valve) |
| FS | Fuel Solenoid (if supplied) |
| HM | Hourmeter (Optional) |
| HTD | High Oil Temperature Switch |
| IM | Ignition Magneto (No. 1 Cylinder) |
| IM2 | Ignition Magneto (No. 2 Cylinder) |
| J1-1 to J1-15 | Run Lamp (Optional) |
| J3 | Low Oil Pressure Switch |
| PCB | Engine Controller Circuit Board |
| R1 | 1 Ohm, 25 watt Resistor |
| SC | Starter Contactor |
| SM | Starter Motor |
| SW1 | Start-Stop Switch |
| SW2 | Fuel Primer Switch |
| SP | No. 1 Spark Plug |
| SP2 | No. 2 Spark Plug |

Figure 5-1. Schematic- DC Control System

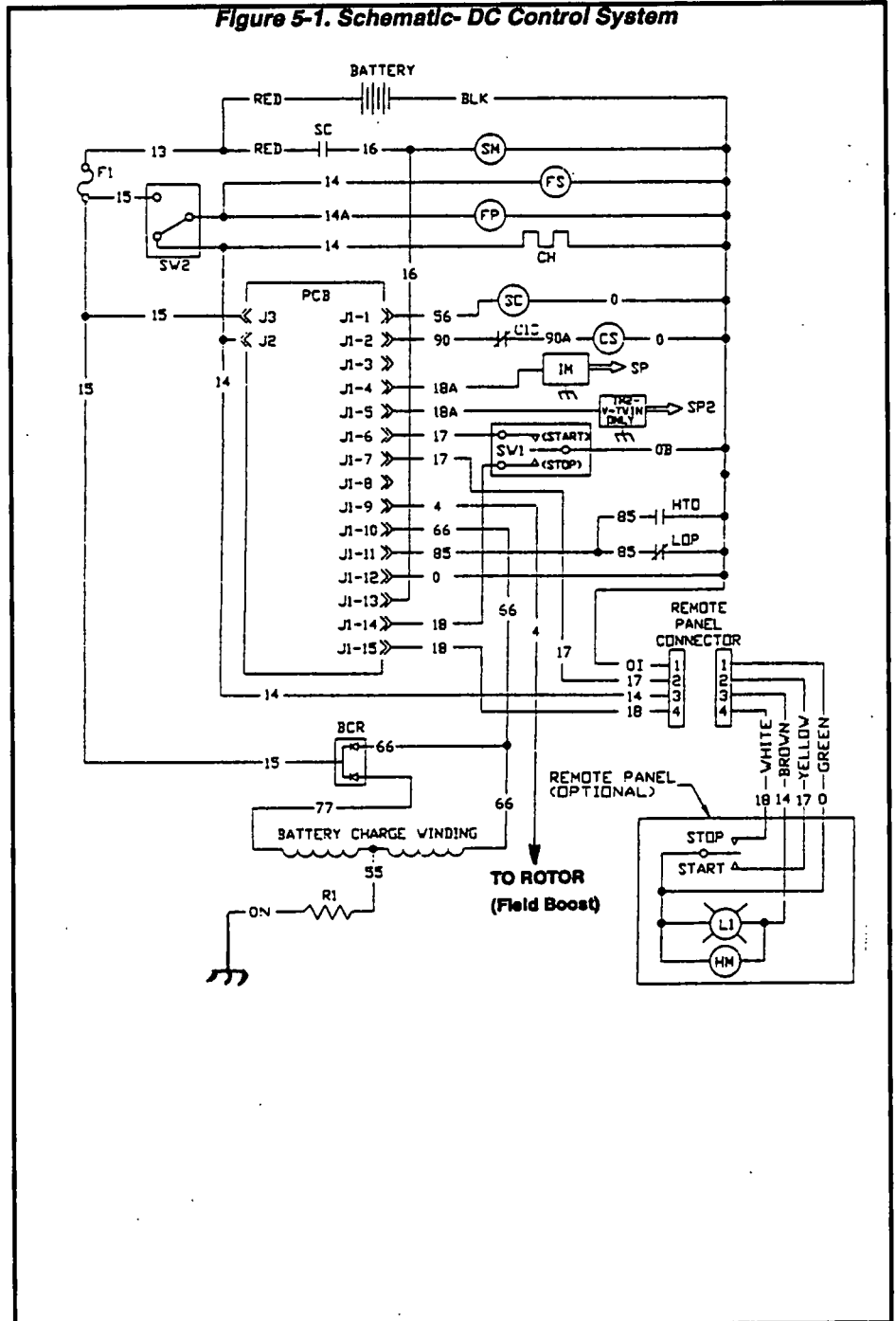

Chapter Five- ENGINE DC CONTROL SYSTEM

Operational Analysis (Continued)

CIRCUIT CONDITION- CRANKING:

While cranking, the CHOKE SOLENOID (CS) is energized cyclically by circuit board action.

Also while cranking, circuit board action delivers battery voltage to the Wire 14/14A circuit. This energizes the FUEL PUMP (FP) and the FUEL SOLENOID (FS). Some units may not be equipped with a FUEL SOLENOID.

In addition, circuit board action delivers battery voltage to the Wire(s) 18A circuit and ignition occurs.

CIRCUIT CONDITION- RUNNING:

With the FUEL PUMP (FP) operating and Ignition occurring, the engine should start.

A voltage is Induced into the Stator's BATTERY CHARGE WINDING. This voltage is delivered to the ENGINE CONTROLLER BOARD (PCB) via Wire 66 to prevent STARTER MOTOR engagement above a certain rpm.

Circuit board action terminates DC output to the STARTER CONTACTOR which then de-energizes to end cranking and CHOKE SOLENOID operation. The choke will go to a position determined by the CHOKE HEATER (CH).

Circuit board action delivers a DC voltage to Wire 4 and to the Rotor. This is FIELD BOOST.

CIRCUIT CONDITION- SHUTDOWN:

Setting the START-STOP SWITCH (SW1) to its "STOP" position connects the Wire 18 circuit to frame ground. Circuit board action then opens the circuit to Wire(s) 18A and to Wire 14. Ignition and fuel flow terminate and the engine shuts down.

CIRCUIT CONDITION- FAULT SHUTDOWN:

The engine mounts a HIGH OIL TEMPERATURE SWITCH (HTO) and a LOW OIL PRESSURE SWITCH (LOP).

Should engine oil temperature exceed a pre-set value, the switch contacts will close. Wire 85 from the circuit board will connect to frame ground. Circuit board action will then initiate a shutdown.

Should engine oil pressure drop below a safe pre-set value, the switch contacts will close. On contacts closure, Wire 85 will be connected to frame ground and circuit board action will initiate an engine shutdown.

Engine Controller Circuit Board

GENERAL:

The engine controller board is the control center for cranking, startup, running and shutdown operations. The board interconnects with other components of the DC control system to turn them on and off at the proper times: It is powered by fused 12 VDC power from the unit battery.

Figure 5-2. Engine Controller Circuit Board

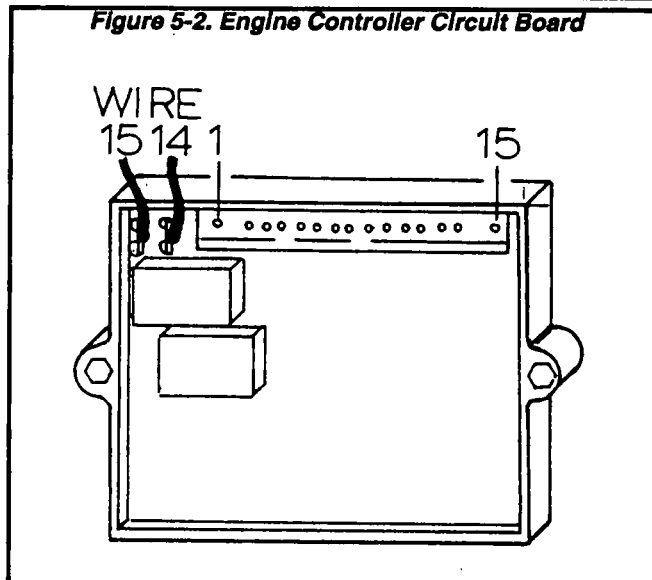

CIRCUIT BOARD CONNECTIONS:

The circuit board mounts a 15-pin receptacle (J1) and two single pin terminals (J2 and J3). Figure 5-3 shows the 15-pin receptacle pins, associated wires and the function(s) of each pin and wire.

Figure 5-3. Receptacle J1

| PIN | WIRE | FUNCTION |
|-----|------|--|
| 1 | 56 | Delivers 12 VDC to Starter Contactor (SC) while cranking only. |
| 2 | 90 | Delivers 12 VDC to Choke Solenoid coil while cranking only. |
| 3 | — | Not used. |
| 4 | 18A | 12 VDC to Ignition Module (IM) while cranking and running. |
| 5 | 18A | 12 VDC to Ignition Module (IM2) while cranking and running. |
| 6 | 17 | To Start-Stop switch. When wire is grounded by setting Start-Stop switch to "START", engine will crank. |
| 7 | 17 | To Start-Stop switch on optional Remote Panel. |
| 8 | — | Not used. |
| 9 | 4 | Field Boost DC to Voltage Regulator and to Rotor windings. |
| 10 | 66 | To Battery Charge Rectifier (BCR). Prevents cranking while engine is running. |
| 11 | 85 | Fault shutdown circuit. When grounded by closure of High Oil Temperature or Low Oil Pressure Switch engine will shut down. |
| 12 | 0 | Common Ground. |
| 13 | 16 | 12 VDC Input to Field Boost circuit while cranking only. |
| 14 | 18 | To Start-Stop switch. When grounded by setting Switch to "STOP" engine shuts down. |
| 15 | 18 | To Start-Stop Switch on optional Remote Panel. |

Chapter Five- ENGINE DC CONTROL SYSTEM

In addition to the 15-pin receptacle (J1), the circuit board is equipped with two single pin terminals (J2 and J3). These terminals may be identified as follows:

1. Wire 14 connects to Terminal J2. During cranking and running, the circuit board delivers battery voltage to the Wire 14 circuit for the following functions:
 - a. To operate the electric Fuel Pump (FP).
 - b. To open the Fuel Solenoid (if so equipped).
 - c. To operate the Choke Heater.
2. Wire 15 connects to Terminal J3. This is the power supply (12 VDC) for the circuit board and the DC control system.

Battery

RECOMMENDED BATTERY:

When anticipated ambient temperatures will be consistently above 32° F. (0° C.), use a 12 volts automotive type storage battery rated 70 amp-hours and capable of delivering at least 360 cold cranking amperes.

If ambient temperatures will be below 32° (0° C.), use a 12 volt battery rated 95 amp-hours and having a cold cranking capacity of 450 amperes.

BATTERY CABLES:

Use of battery cables that are too long or too small in diameter will result in excessive voltage drop. For best cold weather starting, voltage drop between the battery and starter should not exceed 0.12 volt per 100 amperes of cranking current.

Select the battery cables based on total cable length and prevailing ambient temperature. Generally, the longer the cable and the colder the weather, the larger the required cable diameter. The following chart applies:

| CABLE LENGTH (IN FEET) | RECOMMENDED CABLE SIZE |
|------------------------|------------------------|
| 0-10 | No. 2 |
| 11-15 | No. 0 |
| 16-20 | No. 000 |

EFFECTS OF TEMPERATURE:

Battery efficiency is greatly reduced by a decreased electrolyte temperature. Such low temperatures have a decided numbing effect on the electrochemical action. Under high discharge rates (such as cranking), battery voltage will drop to much lower values in cold temperatures than in warmer temperatures. The freezing point of battery electrolyte fluid is affected by the state of charge of the electrolyte as indicated below:

| SPECIFIC GRAVITY | FREEZING POINT |
|------------------|-------------------|
| 1.220 | -35° F. (-37° C.) |
| 1.200 | -20° F. (-29° C.) |
| 1.160 | 0° F. (-18° C.) |

ADDING WATER:

Water is lost from a battery as a result of charging and discharging and must be replaced. If the water is not replaced and the separator plates become exposed, they may become permanently sulfated. In addition, the plates cannot take full part in the battery action unless they are completely immersed in electrolyte. Add only DISTILLED WATER to the battery. DO NOT USE TAP WATER.

NOTE: Water cannot be added to some "maintenance-free" batteries.

CHECKING BATTERY STATE OF CHARGE:

Use an automotive type battery hydrometer to test the battery state of charge. Follow the hydrometer manufacturer's instructions carefully. Generally, a battery may be considered fully charged when the specific gravity of its electrolyte is 1.260. If the hydrometer used does not have a "Percentage of Charge" scale, compare the readings obtained with the following:

| SPECIFIC GRAVITY | PERCENTAGE OF CHARGE |
|------------------|----------------------|
| 1.260 | 100% |
| 1.230 | 75% |
| 1.200 | 50% |
| 1.170 | 25% |

CHARGING A BATTERY:

Use an automotive type battery charger to recharge a battery. Battery fluid is an extremely caustic sulfuric acid solution that can cause severe burns. For that reason, the following precautions must be observed:

- The area in which the battery is being charged must be well ventilated. When charging a battery, an explosive gas mixture forms in each cell.
- Do not smoke or break a live circuit near the top of the battery. Sparking could cause an explosion.
- Avoid spillage of battery fluid. If spillage occurs, flush the affected area with clear water immediately.
- Wear eye protection when handling a battery.

15 Amp Fuse

This panel-mounted Fuse protects the DC control circuit against overload and possible damage. If the Fuse has melted open due to an overload, neither the priming function nor the cranking function will be available.

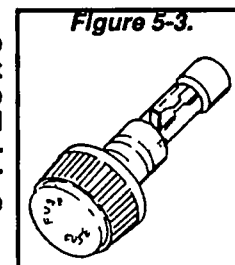

Figure 5-3.

Chapter Five- ENGINE DC CONTROL SYSTEM

Fuel Primer Switch

Following generator installation and after the unit has been idle for some time, the fuel supply line may be empty. This condition will require a long cranking period before fuel can reach the carburetor. The Fuel Primer Switch, when actuated to its "PRIME" position will open a Fuel Solenoid (FS), if so equipped. In addition, battery voltage will be delivered across the closed switch contacts to the Fuel Pump (FP) to turn the Pump on. Pump action will then draw fuel from the supply tank to prime the fuel lines and carburetor.

Figure 5-4. Primer Switch

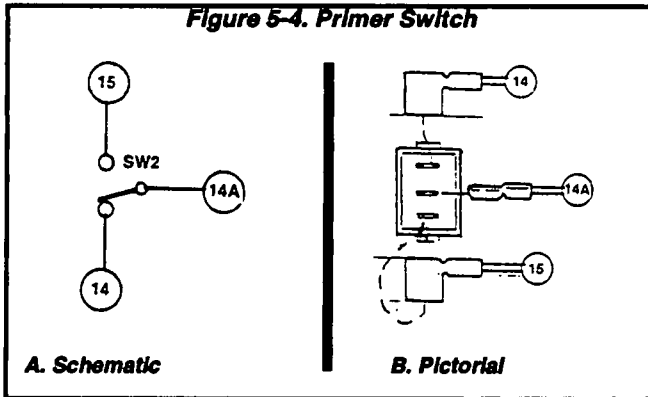

Start-Stop Switch

Switch allows the operator to control cranking, startup and shutdown. The following wires connect to the Start-Stop Switch:

1. Wire No. 17 from the Engine Controller circuit board. This is the CRANK and START circuit. When the Switch is set to "START", Wire 17 is connected to frame ground via Wire 0B.

a. With Wire 17 grounded, a Crank Relay on the circuit board energizes and battery voltage is delivered to the Starter Contactor via Wire 56. The Starter contactor energizes, its contacts close and the engine cranks.

b. With Wire 17 grounded, a Run Relay on the circuit board energizes and battery voltage is delivered to the Wire 14 circuit.

(1) Battery voltage is delivered to the Fuel Pump, Fuel Solenoid (if so equipped) and the Choke Heater.

(2) Battery voltage is delivered to the Ignition Modules (IM and IM2). Ignition occurs.

2. Wire 18 from the Engine Controller board. This is the ENGINE STOP circuit. When the Start-Stop Switch is set to "STOP", Wire 18 is connected to frame ground. Circuit board action then opens the circuit to Wires 14 and 18A. Fuel flow to the carburetor and ignition are terminated.

3. Wire 0B connects the Switch to frame ground by means of a 4-tab grounding terminal.

Figure 5-5. Start-Stop Switch

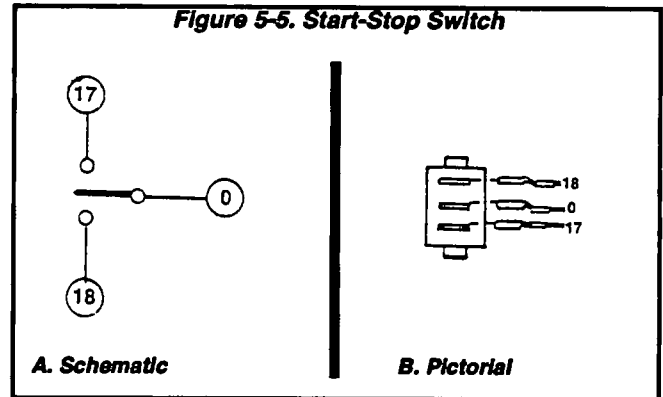

Starter Contactor & Motor

The positive (+) battery cable (13) attaches to one of the large lugs of the Contactor. The Starter cable (16) attaches to the second large lug. Attached to the two small lugs are Wires 56 and 0.

When the Start-Stop switch is set to "START", the circuit board delivers battery voltage to the Contactor coil via Wire 56. The Contactor energizes and its contacts close. Battery voltage is then delivered from the positive battery cable, across the closed contacts and to the Starter Motor via Wire 16.

Figure 5-6. Starter Contactor

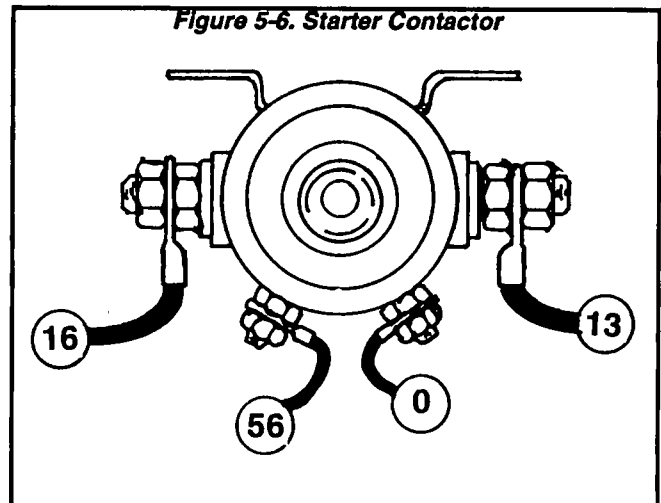
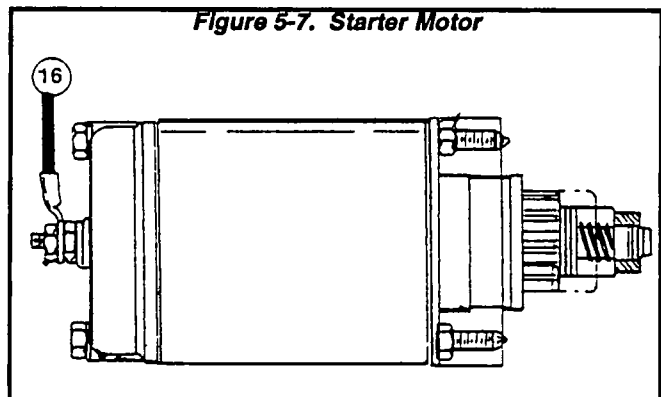

Figure 5-7. Starter Motor



Chapter Six- TROUBLESHOOTING FLOW CHARTS

Introduction

The "Flow Charts" in this chapter may be used in conjunction with the "Diagnostic Tests" of Chapter Seven. Numbered tests in the Flow Charts correspond to identically numbered tests of Chapter Seven.

Problems 1 through 5 apply to the AC generator only.

Beginning with Problem 6, the engine DC control system is dealt with.

If Problem Involves AC Generator

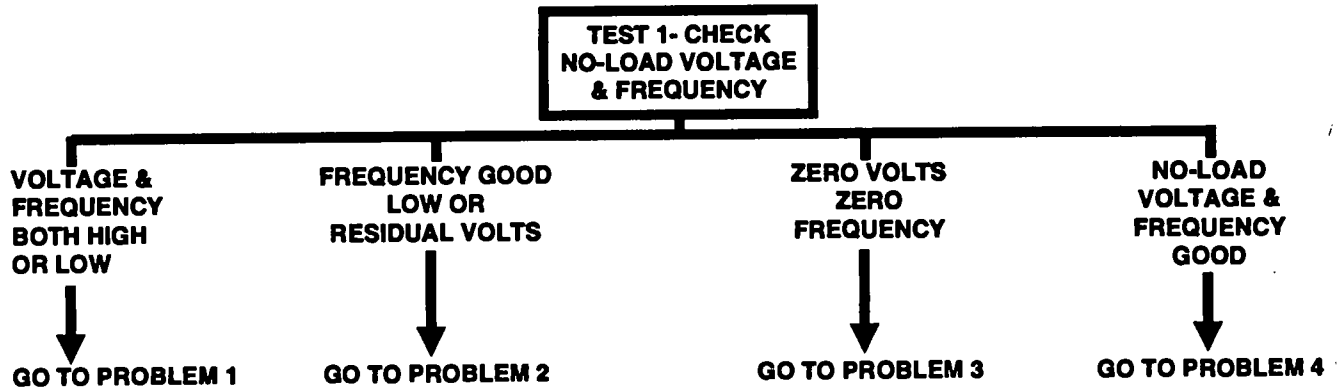

Problem 1- Voltage & Frequency Are Both High or Low

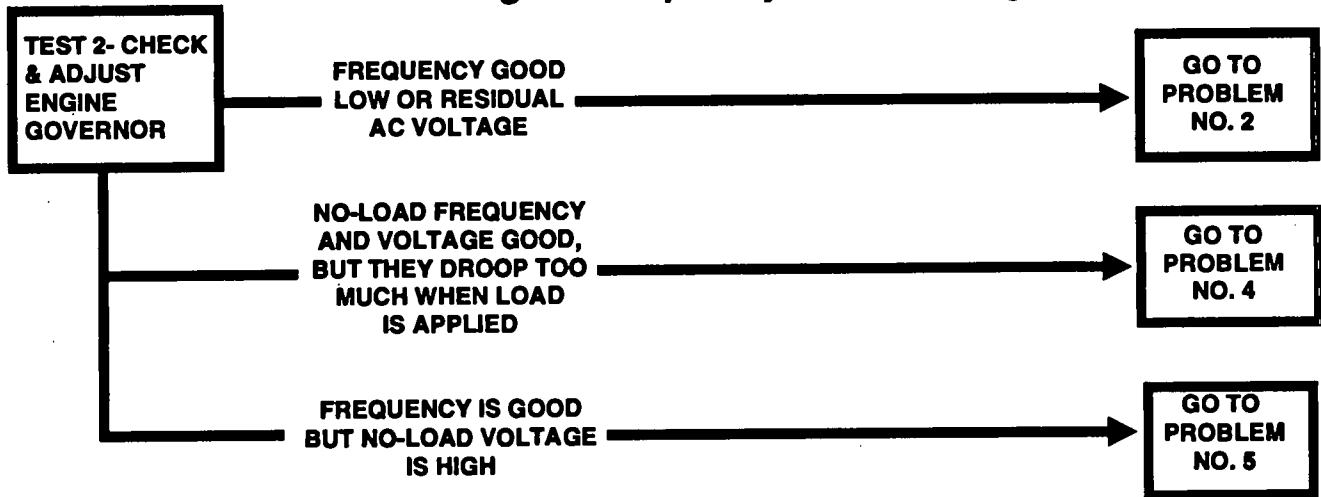

Problem 2- Frequency Good But Voltage Low or Residual

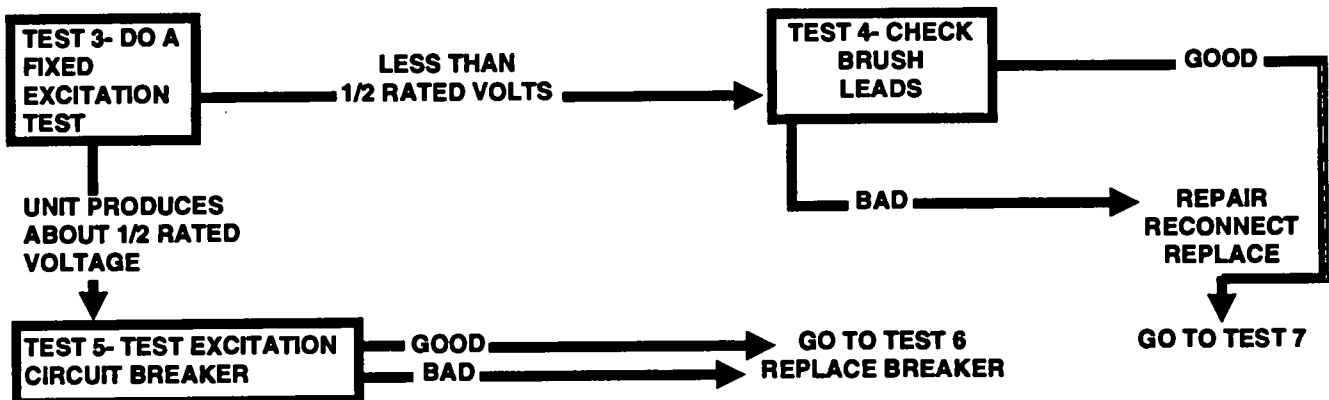

Chapter Six- TROUBLESHOOTING FLOW CHARTS

Problem 2- Frequency Good, Voltage Low or Residual (Continued)

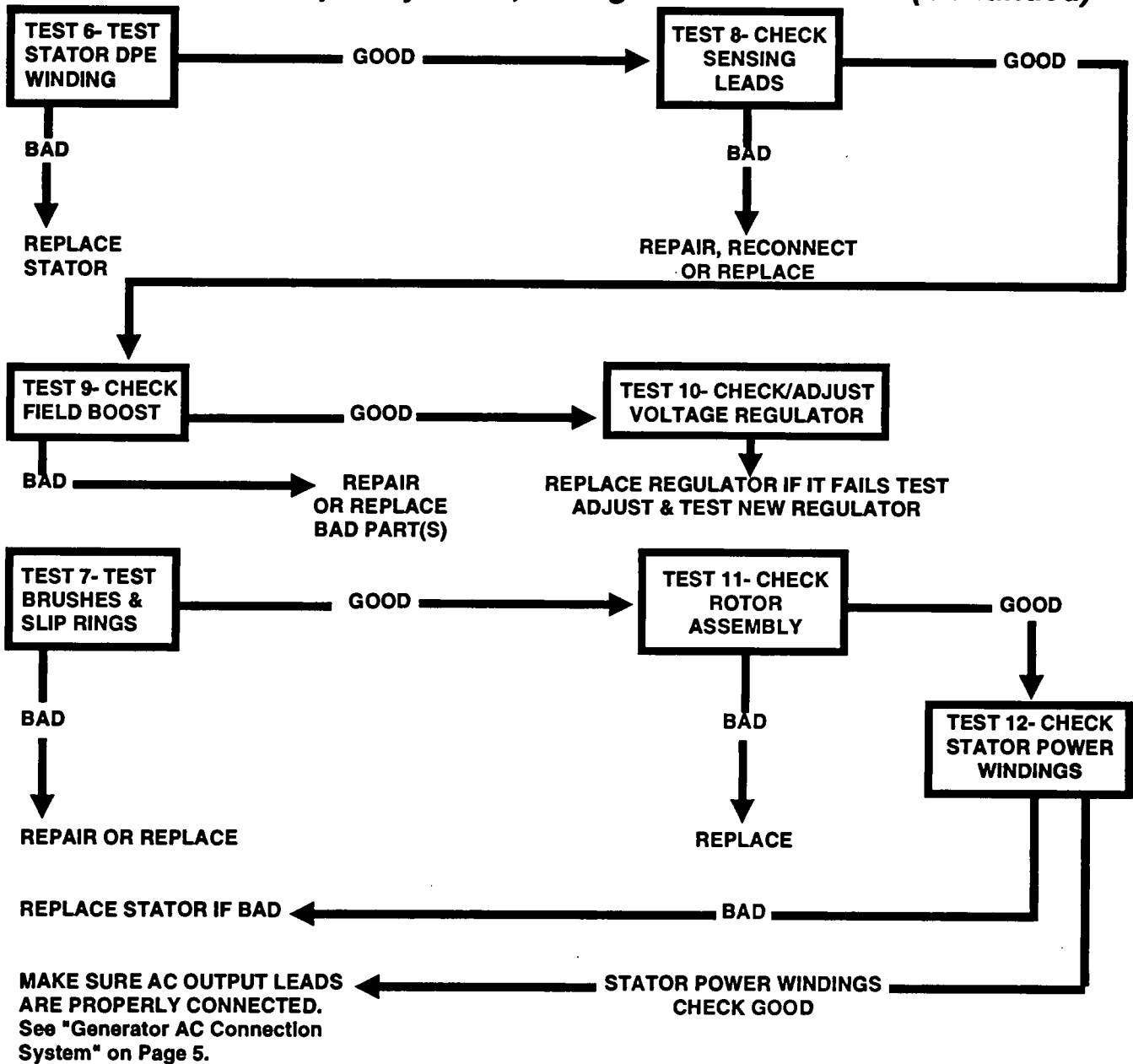

NOTE: The term "Low Voltage" refers to any AC output voltage that is less than rated voltage. The term "Residual Voltage" refers to AC output voltage produced by Rotor residual magnetism alone and without excitation current (about 5-12 volts AC).

Problem 3- Frequency and Voltage Both Read Zero

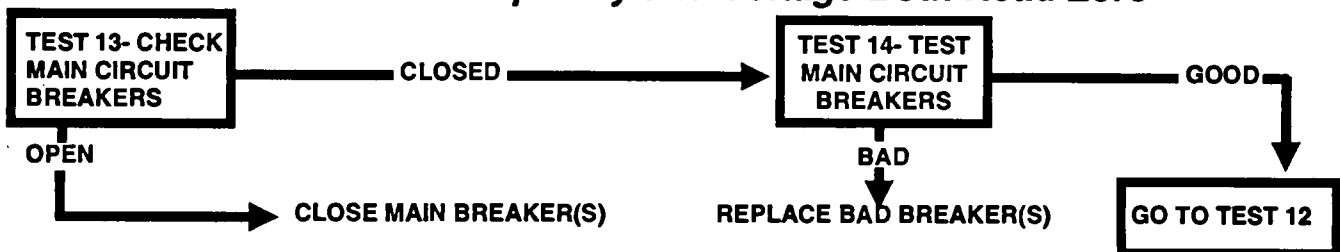

Chapter Six- TROUBLESHOOTING FLOW CHARTS

Problem 3- Frequency and Voltage Both Read Zero (Continued)

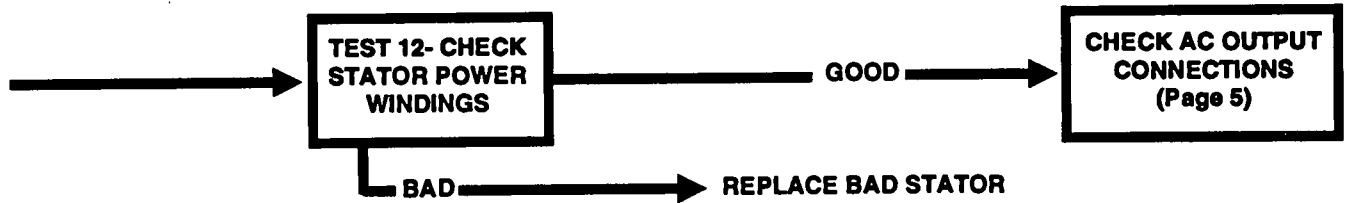

Problem 4- Excessive Voltage/Frequency Droop When Load is Applied

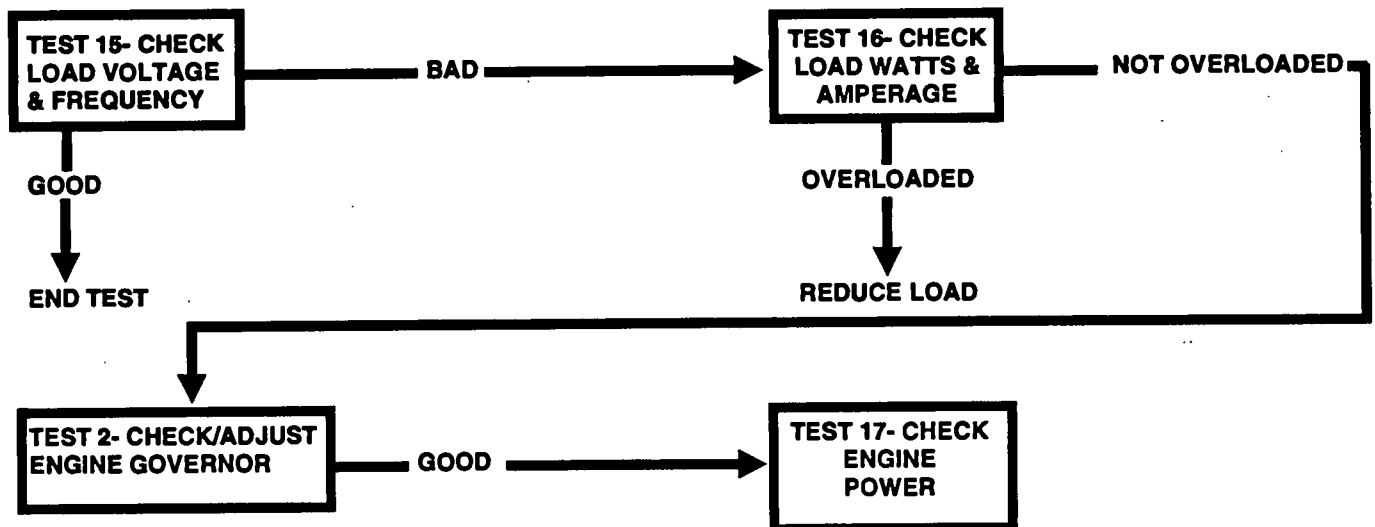

Problem 5 and up apply to the engine DC control system.

Problem 5- Priming Function Does Not Work

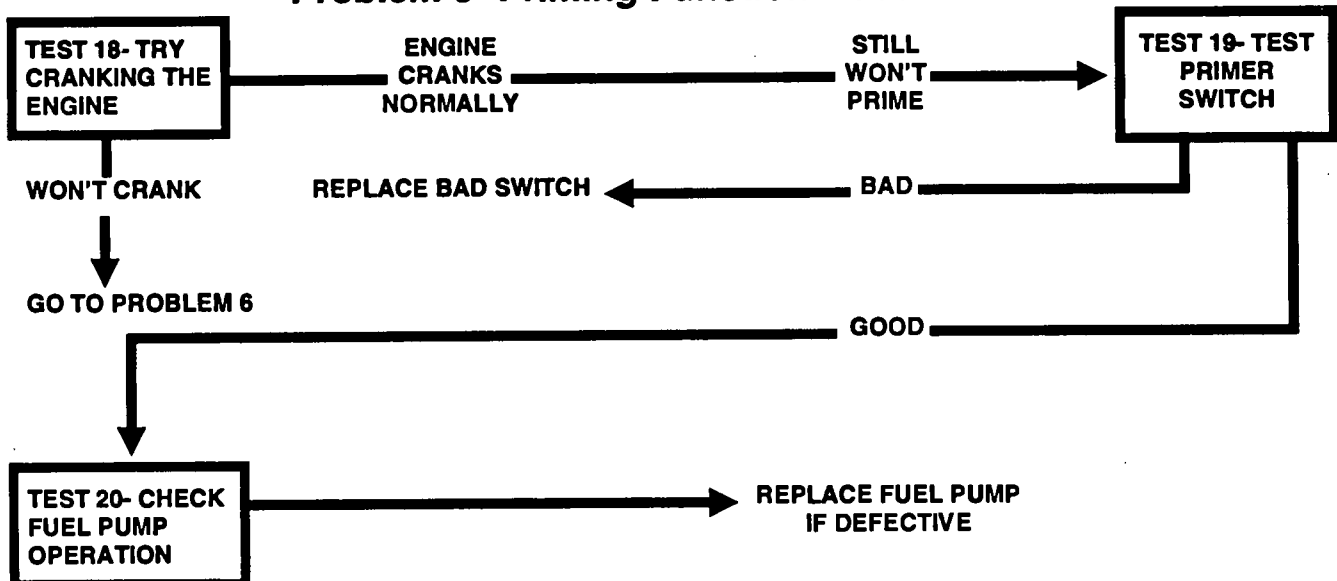

Chapter Six- TROUBLESHOOTING FLOW CHARTS

Problem 6- Engine Will Not Crank

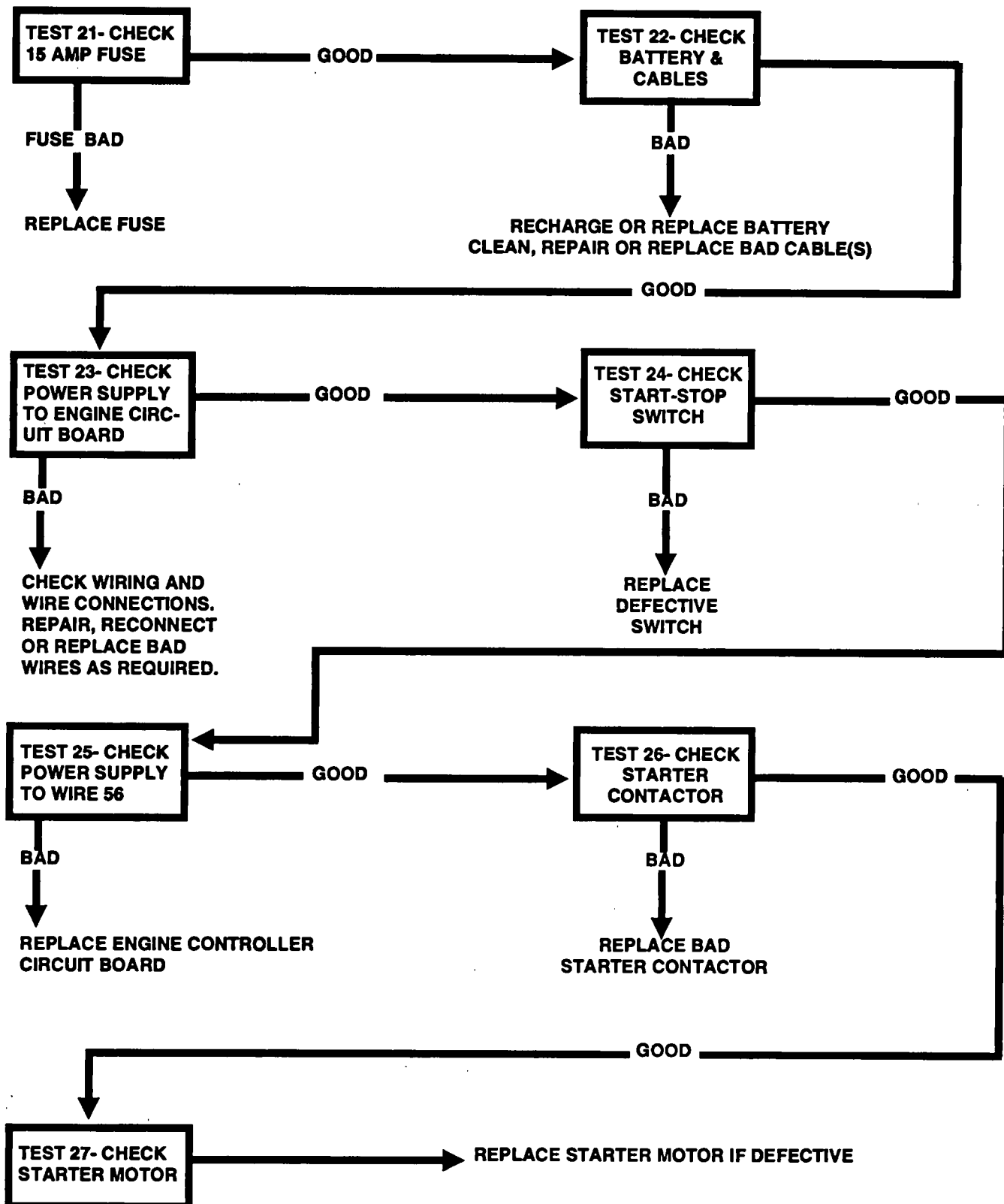

Chapter Six- TROUBLESHOOTING FLOW CHARTS

Problem 7- Engine Cranks But Won't Start

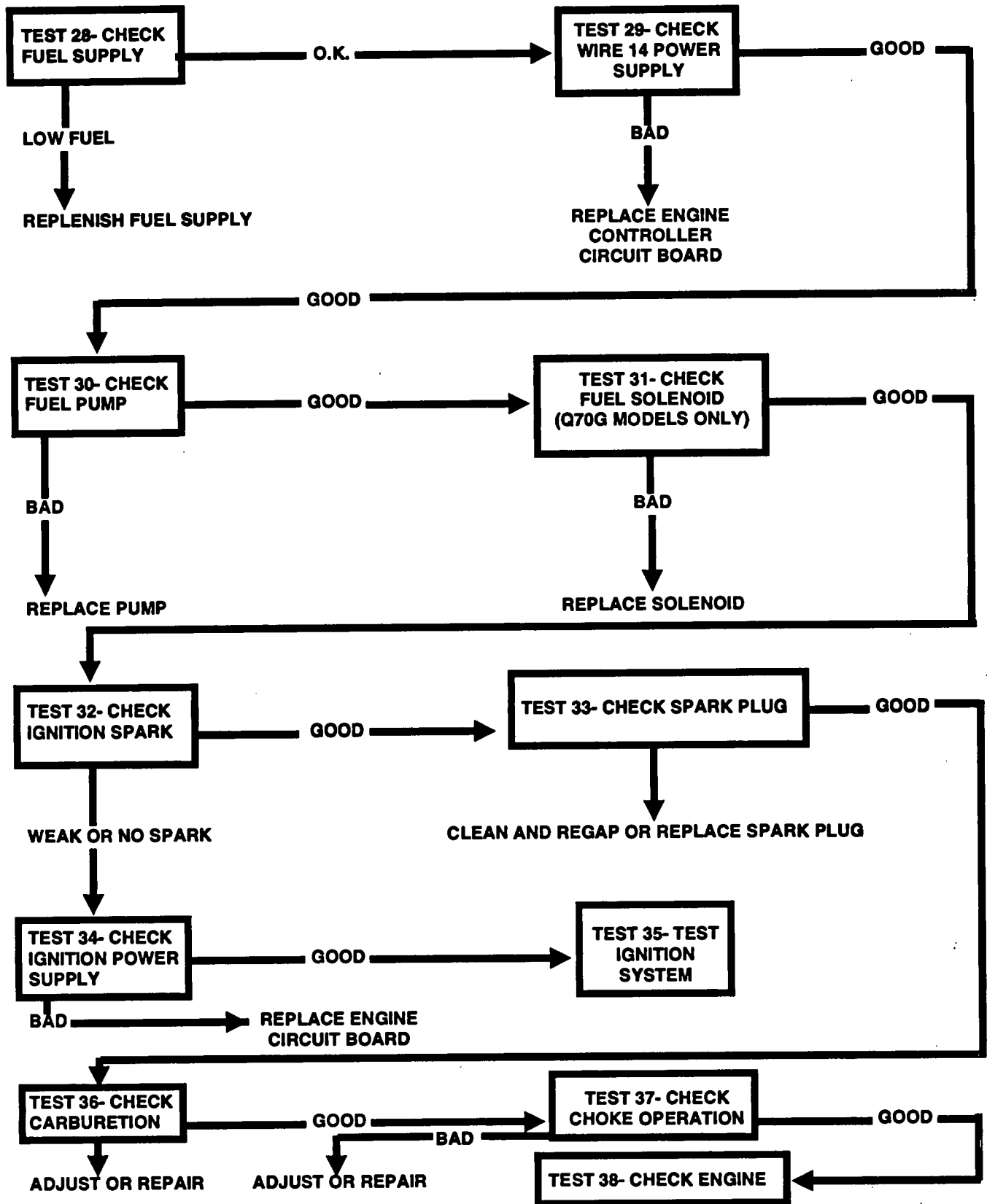

Chapter Six- TROUBLESHOOTING FLOW CHARTS

Problem 8- Engine Starts Hard and Runs Rough

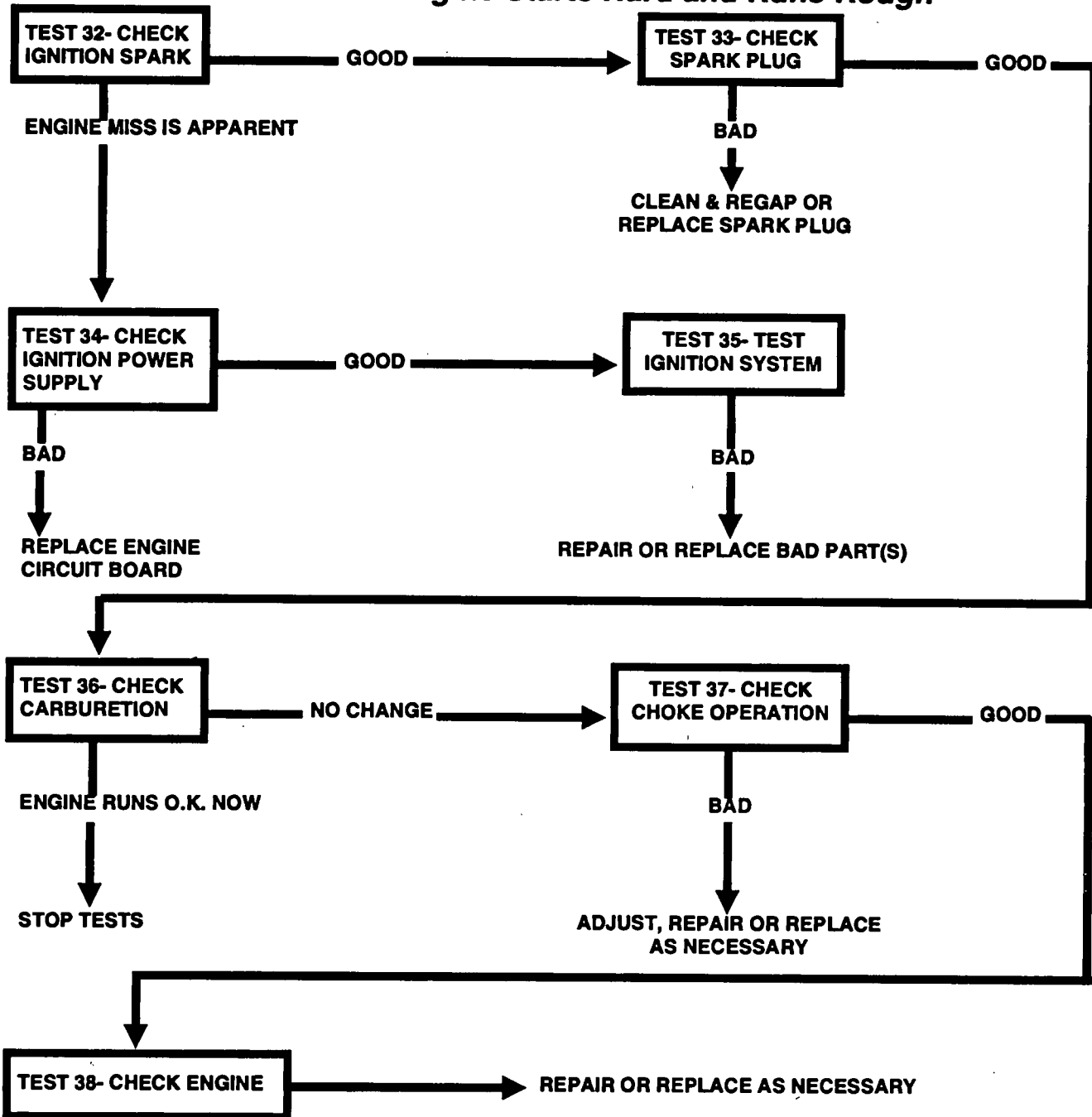

Chapter Six- TROUBLESHOOTING FLOW CHARTS

Problem 9- Engine Starts and Then Shuts Down

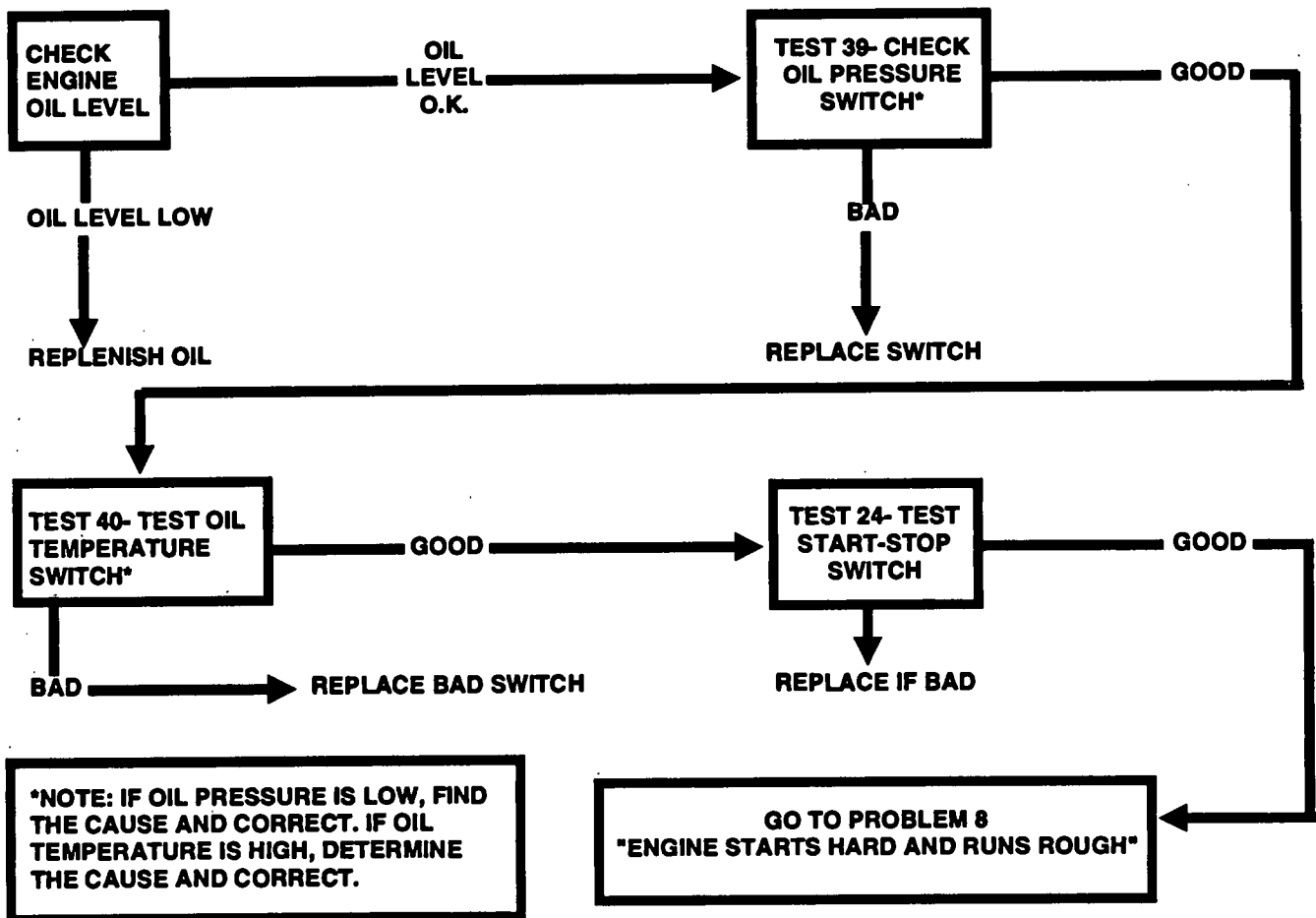

Chapter Six- TROUBLESHOOTING FLOW CHARTS

Chapter Seven- DIAGNOSTIC TESTS

Introduction

The "Diagnostic Tests" in this chapter may be performed in conjunction with the "Flow Charts" of Chapter Six. Test numbers in this chapter correspond to the numbered tests in the "Flow Charts".

Tests 1 through 17 are procedures involving problems with the AC generator's output voltage and frequency (Problems 1 through 4 in the "Flow Charts").

Tests 17 through 40 are procedures involving problems with engine operation (Problems 5 through 9 in the "Flow Charts").

You may wish to read Chapter Four, "Measuring Electricity".

NOTE: Test procedures in this Manual are not necessarily the only acceptable methods for diagnosing the condition of components and circuits. All possible methods that might be used for system diagnosis have not been evaluated. If you use any diagnostic method other than the method presented in this Manual, you must ensure that neither your safety nor the product's safety will be endangered by the procedure or method you have selected.

Test 1- Check No-Load Voltage and Frequency

DISCUSSION:

The first step in analyzing any problem with the AC generator is to determine the unit's AC output voltage and frequency. Once that has been done, you will know how to proceed with specific diagnostic tests.

The generator's AC output leads may be connected to supply either single or dual voltage output. You may wish to review "Generator AC Connection System" on Page 5.

PROCEDURE:

1. Set a volt-ohm-milliammeter (VOM) to read AC voltage. Connect the meter test leads across customer connection leads T1 (Red) and T2 (White).
2. Connect an AC frequency meter across AC output leads T3 (Black) and T2 (White).
3. Disconnect or turn OFF all electrical loads. Initial checks and adjustments are accomplished at no-load.
4. Start the engine, let it stabilize and warm up.
5. Read the AC voltage and frequency.
 - a. For units rated 60 Hertz, no-load voltage and frequency should be approximately 122-126 VAC and 61-63 Hertz respectively.
 - b. For units rated 50 Hertz, no-load voltage should be approximately 110-112 VAC at 50-52 Hertz.
6. Repeat the above with the frequency meter across T3 (Black) and T2 (White) and with the VOM across T3 (Black) and T2 (White). Frequency and voltage readings should be the same as Step 5.

RESULTS:

1. If AC voltage and frequency are BOTH correspondingly high or low, go to Test 2.
2. If AC frequency is good but low or residual voltage is indicated, go to Test 3.
3. If AC output voltage and frequency are both "zero", go to Test 13.
4. If the no-load voltage and frequency are within the stated limits, go to Test 15.

NOTE: The term "low voltage" refers to any voltage reading that is lower than the unit's rated voltage. The term "residual voltage" refers to the output voltage supplied as a result of Rotor residual magnetism only (approximately 5-12 VAC).

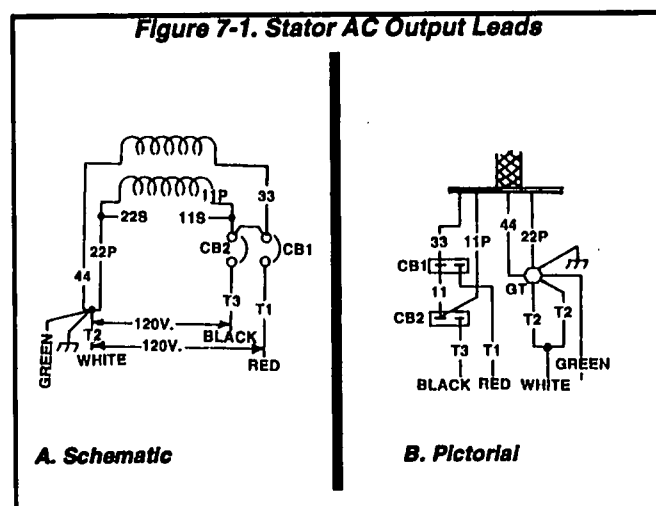

Test 2- Check Engine Governor

DISCUSSION:

Rotor operating speed and AC output frequency are proportional. The generator will deliver a frequency of 60 Hertz at 3600 Rotor rpm or 62 Hertz at 3720 Rotor rpm.

The Voltage Regulator should be adjusted to deliver 120 VAC (line-to-neutral) at a frequency of 60 Hertz; or 124 VAC (line-to-neutral) at 62 Hertz. It is apparent that, if governed speed is high or low, AC frequency and voltage will be correspondingly high or low. Governed speed at no-load is usually set slightly above the rated speed of 60 Hertz (to 62 Hertz), to prevent excessive rpm, frequency and voltage droop under heavy electrical loading.

NOTE: Generator Models 9712-0 and 9712-1 are powered by a single cylinder GN-360 engine. Other applicable models are powered by a V-Twin engine. Governor adjustment procedures for both engines will be discussed in the following procedure.

Chapter Seven- DIAGNOSTIC TESTS

Test 2- Check Engine Governor (Continued)

PROCEDURE FOR V-TWIN ENGINE:

1. For gasoline fuel systems, adjust the carburetor as follows:

- a. Turn the IDLE MIXTURE VALVE clockwise until it just seats. DO NOT FORCE.
- b. Turn the IDLE MIXTURE VALVE counterclockwise 1-1/4 turns. This setting will allow the engine to be started and warmed up, at which time final adjustment can be completed.

2. For units with gaseous fuel system, complete adjustment of the load block prior to start.

- a. Turn both the IDLE ADJUST and the SLOTTED ADJUSTMENT clockwise until they are softly seated. DO NOT FORCE.
- b. For units rated 6600, 7000 and 7200 watts, turn both adjustments counterclockwise 1-1/2 turns.
- c. For units rated 5000, 5200 and 5500 watts, turn both adjustments counterclockwise 2 turns.
- d. Hold the adjustment and tighten the LOAD BLOCK LOCK NUT.

The above load block adjustment should allow the engine to be started, when final adjustment can be made.

CAUTION!

The static governor adjustment outlined in Step 3 must be made following governor maintenance before the engine is started. Failure to complete the adjustment could result in overspeeding of the engine. Such overspeeding could result in engine damage, personal injury or property damage. All linkage MUST be installed to make this adjustment.

3. Complete a STATIC GOVERNOR adjustment as follows:

- a. See Figure 7-4. Loosen the GOVERNOR CLAMP NUT.
- b. Push the GOVERNOR LEVER until the throttle is wide open. DO NOT BEND THE GOVERNOR LINK.
- c. Hold the GOVERNOR LEVER in the "wide open throttle" position and rotate the GOVERNOR SHAFT counterclockwise (CCW) as far as it will go.
- d. While holding the GOVERNOR SHAFT in its full counterclockwise position, tighten the GOVERNOR CLAMP NUT to 70 inch-pounds (8 N-m).

NOTE: Clearance is limited on ducted engines. A standard torque wrench and socket may not work. An M6 crows foot wrench will allow proper torquing.

4. Adjust the governor as follows:

Figure 7-2. Carburetor Adjustment (V-Twin)

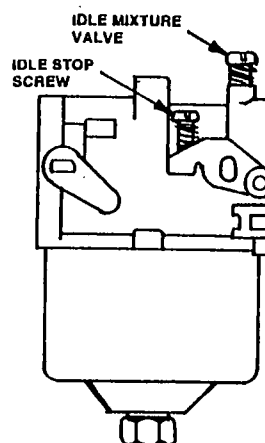

Figure 7-3. Load Block Adjustment (Gaseous)

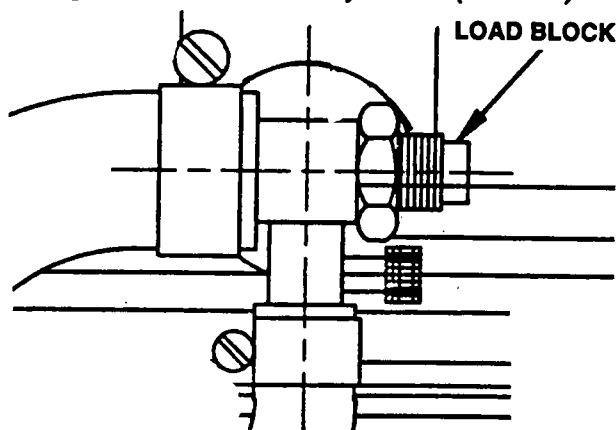
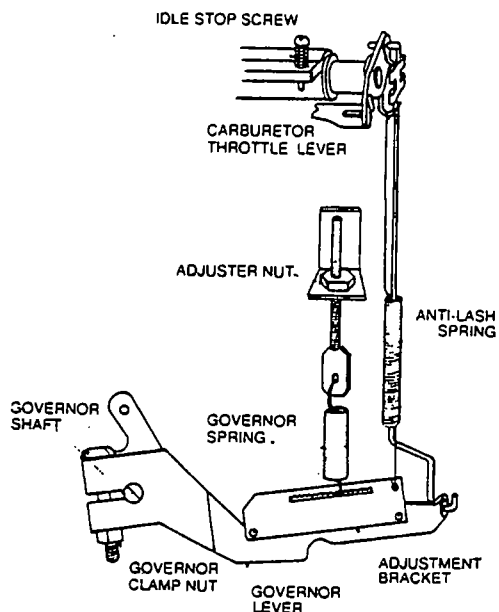

Figure 7-4. Governor Adjustment (V-Twin)



Chapter Seven- DIAGNOSTIC TESTS

- a. Inspect the ANTI-LASH SPRING. Make sure it is not broken or disengaged.
- b. Connect an accurate AC frequency meter to the generator's AC output leads.
- c. Start the engine, let it stabilize and warm up at no-load.
- d. Turn the ADJUSTER NUT to obtain a frequency reading as close as possible to 62 Hertz for units rated 60 Hertz; or 51 Hertz for units rated 50 Hertz.
- e. Apply an electrical load as close as possible to the unit's full rated wattage/ampere capacity. With load applied, note the amount of frequency droop. Also note whether excessive hunting occurs when the load is removed.

(1) If frequency droops below 58 Hertz when the load is applied, disconnect the load. Then, move the GOVERNOR SPRING in the ADJUSTMENT BRACKET closer to the ANTI-LASH SPRING.

(2) Readjust the ADJUSTER NUT to obtain a no-load frequency as close as possible to 62 Hertz (60 Hertz units); or 51 Hertz (50 Hertz units).

(3) Again apply a load and check for droop and hunting.

(4) Continue the above procedure until (a) no load speed is correct, (b) excessive droop under load does not occur, and (c) excessive hunting does not occur when the load is removed.

NOTE: Final carburetor adjustments may be required for best results. Units with gaseous fuel system may require final load block adjustments.

PROCEDURE FOR GN-360 ENGINE:

1. Before starting the engine, complete initial adjustment of the governor as follows (Figure 7-5):

a. Loosen the GOVERNOR LEVER CLAMP BOLT.

b. Hold the GOVERNOR LEVER at its full "INC. RPM" position and rotate the GOVERNOR SHAFT clockwise as far as it will go. Then, tighten the GOVERNOR LEVER CLAMP BOLT to 70 inch-pounds (8 N-m).

2. Connect an AC frequency meter across the generator's AC output leads.

3. Turn OFF or disconnect all electrical loads. Then, start the engine, let it stabilize and warm up. Finally, adjust the governor as follows:

a. Check the AC frequency reading.

(1) For units rated 60 Hertz, the no-load frequency should be 61.5-63.5 Hertz.

(2) For units rated 50 Hertz, frequency should be 50.5-51.5 Hertz.

b. If frequency is incorrect, turn the SPEED ADJUST NUT (Figure 7-5) until correct frequency is obtained.

Figure 7-5. Governor Adjustment (GN-360 Engine)

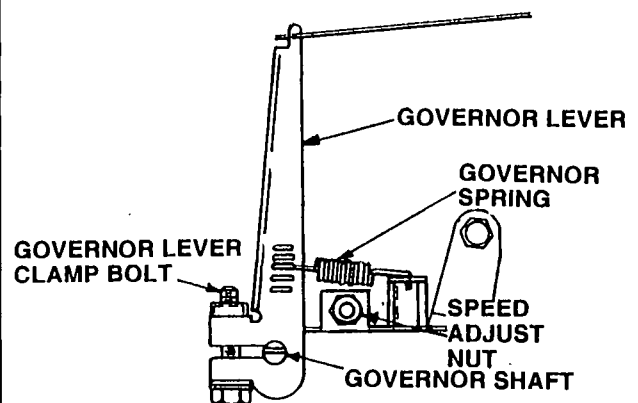
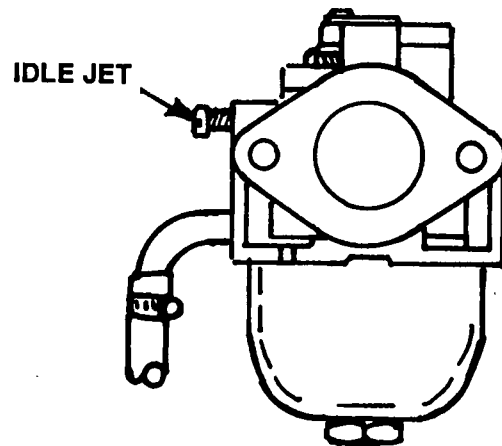

Figure 7-6. Carburetor Adjustment (GN-360 Engine)



c. If frequency is unstable, turn the IDLE JET on carburetor (Figure 7-6) until engine stabilizes. DO NOT TURN THE IDLE JET FURTHER THAN NECESSARY.

3. Apply a load as close as possible to the unit's maximum rated wattage capacity. Then, adjust the carburetor as follows:

a. If carburetor has a fixed main jet, slowly adjust the carburetor IDLE JET to obtain the best operation and highest rpm under load.

b. If the carburetor has an ADJUSTABLE main jet, adjust it as follows:

(1) Loosen the main jet LOCKNUT at bottom of carburetor.

(2) Slowly turn the main jet counterclockwise (richer) until frequency (rpm) starts to drop off.

(3) Turn the main jet clockwise (leaner) until frequency again starts to drop off.

(4) Finally, turn the main jet counterclockwise until the best and most stable frequency (rpm) is obtained.

Chapter Seven- DIAGNOSTIC TESTS

Test 2- Check Engine Governor (Continued)

PROCEDURE FOR GN-360 ENGINE (CONT'D):

- (5) Hold the adjustment of Step (5) and tighten the main jet LOCKNUT.
- (6) Turn OFF or disconnect all electrical loads and repeat Step 3.

Test 3- Do a Fixed Excitation Test

DISCUSSION:

The fixed excitation test consists of applying battery voltage (12 VDC) to the Rotor windings. This allows that portion of the excitation circuit between the Voltage Regulator and the Rotor (including the Rotor itself) to be checked as a possible cause of the problem. When battery voltage is applied to the Rotor, the resulting magnetic field around the Rotor should induce a Stator power winding voltage equal to about one-half the unit's rated output voltage.

Figure 7-7. Fixed Excitation Test

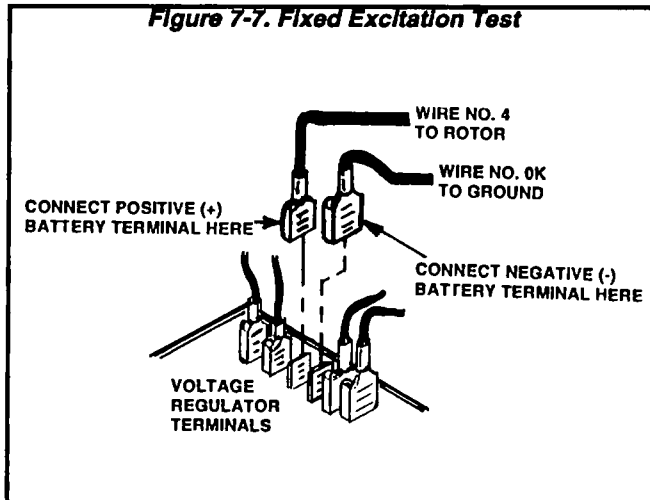

PROCEDURE:

1. Connect a jumper wire to the positive (+) terminal of a 12 volt battery. Do NOT connect the other end of this wire now. Set the wire in a safe place where it will not make contact and cause arcing.
2. Disconnect Wires No. 4 and 0K from the Voltage Regulator (inside the generator panel).
3. Connect a second jumper wire to the negative (-) terminal of the 12 volt battery. Connect the opposite end of this jumper wire to the Wire No. 0K that was disconnected from the Regulator.
4. Connect the test leads of an AC voltmeter or a volt-ohm-milliammeter (VOM) across the generator's AC output leads.
5. Start the generator engine, let it stabilize and warm up.
6. Connect the jumper wire from the positive (+) battery terminal to Wire No. 4 (previously disconnected from the Regulator). The voltmeter or VOM

should indicate approximately 45-55 percent of the unit's rated voltage.

7. Stop the engine and reconnect Wires 4 and 0K to the Voltage Regulator.

RESULTS:

1. If AC voltage reading is less than 55-65 percent of rated voltage, go to Test 4. (The brush leads, brushes and slip rings, and the Rotor are suspect.)
2. If AC output voltage is about 55-65 percent of rated voltage, go to Test 5. (The Stator excitation windings, excitation circuit breaker, Voltage Regulator and interconnecting wires are suspect.)

Test 4- Check Brush Leads

DISCUSSION:

In Test 3, if application of battery voltage to the Rotor did NOT result in an output of about one-half rated voltage, the brush leads could be one possible cause of the problem. This test will check Wires 4 and 0K, as well as the negative brush ground lead, for open circuit.

PROCEDURE:

1. Set a VOM to its "Rx1" scale and zero the meter.
2. Disconnect Wire No. 4 (Red) from the Voltage Regulator and from the Rotor brush terminal.
3. Connect the VOM test leads across the ends of the wire. The meter should read "continuity".
4. Disconnect Wire No. 0K from the Voltage Regulator.
 - a. Connect the meter test leads across terminal end of Wire 0K and the 4-tab grounding terminal to which opposite end of wire attaches.
 - b. The meter should read "continuity".
5. Check the short length of Wire 0F, between the brush negative (-) terminal and brush holder mounting screw, for "continuity".

RESULTS:

1. Repair, reconnect or replace any defective wire(s).
2. If wires check good, go to Test 7.

Figure 7-8. Brush Leads

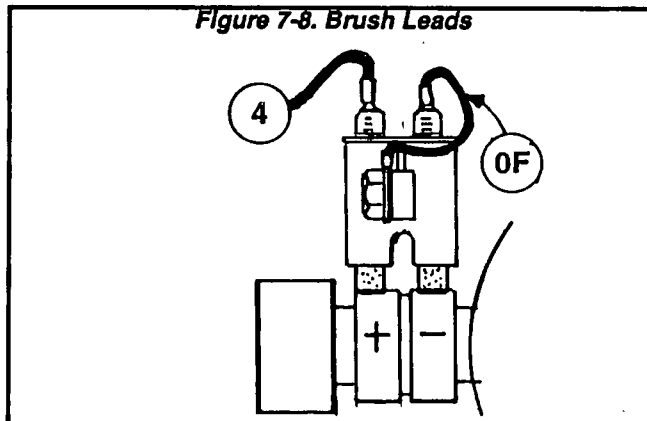

Chapter Seven- DIAGNOSTIC TESTS

Test 5- Test Excitation Circuit Breaker

DISCUSSION:

This circuit breaker is normally-closed and self-resetting. It will open in the event of high voltage from the Stator excitation (DPE) winding. The breaker should re-close when excitation winding output voltage to the Voltage Regulator drops to normal.

When the breaker is open, excitation current to the Regulator (and to the Rotor) will be lost. The unit's AC output voltage will then drop to a value that is commensurate with the Rotor's residual magnetism (about 5-12 volts AC). This test will determine if the breaker has failed in its open position.

Figure 7-9. Excitation (DPE) Circuit Breaker

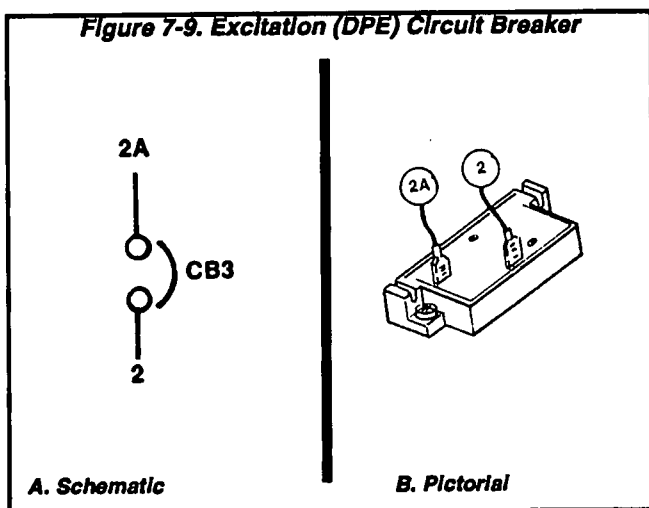

PROCEDURE:

1. Set a volt-ohm-milliammeter (VOM) to its "Rx1" scale and zero the meter.
2. In the generator panel, locate the excitation circuit breaker. Disconnect Wires No. 2 and 2A from the breaker terminals.
3. Connect the meter test leads across the two circuit breaker terminals. The meter should indicate "continuity".

RESULTS:

1. If the meter did NOT read "continuity", replace the excitation (DPE) circuit breaker.
2. If "continuity" was indicated, go to Test 6.

Test 6- Test Stator DPE Winding

DISCUSSION:

An open circuit in the Stator excitation windings will result in a loss of unregulated excitation current to the Voltage Regulator. The flow of regulated excitation current to the Rotor will then terminate and the unit's AC output voltage will drop to a value

that is commensurate with the Rotor's residual magnetism.

A shorted condition in the excitation windings will result in partial loss of excitation current to the Regulator and to the Rotor. A badly shorted winding can cause overheating and damage to Stator windings.

Figure 7-9A. Stator Excitation Winding

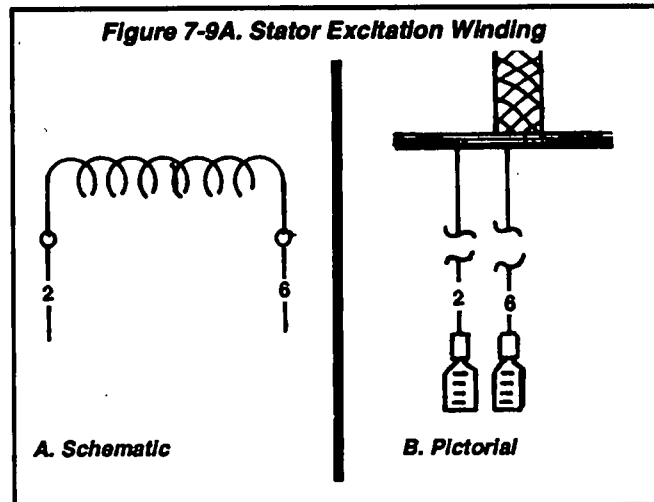

PROCEDURE:

1. Disconnect Wire No. 2 from the excitation circuit breaker.
2. Disconnect Wire No. 6 from the Voltage Regulator.
3. Set a VOM to its "Rx1" scale and zero the meter.
4. Connect the VOM test leads across the terminal ends of Wires No. 2 and 6. The VOM should indicate the resistance of the Stator excitation (DPE) windings.

| NOMINAL RESISTANCE OF STATOR DPE WINDINGS* | | | | | | |
|--|------|------|------|------|------|------|
| UNIT RATED WATTS | 5000 | 5200 | 5500 | 6600 | 7000 | 7200 |
| OHMS | 1.43 | 1.43 | 1.43 | 1.60 | 1.55 | 1.55 |

* Resistance values in ohms at 20° C. (68° F.). Actual readings may vary depending on ambient temperature. A tolerance of plus or minus 5% is allowed.

5. Now, set the meter to its "Rx1K" or "Rx10,000" scale and zero the meter. Test for a "short-to-ground" condition as follows:
 - a. Connect one meter test lead to Stator lead No. 2, the other test lead to a clean frame ground.
 - b. The meter should read "Infinity". Any other reading indicates a "short-to-ground" condition and the Stator should be replaced.
6. Test for a short between windings as follows:
 - a. Meter should be set to its "Rx1K" or "Rx10,000" scale.

Chapter Seven- DIAGNOSTIC TESTS

Test 6- Test Stator DPE Winding (Continued)

PROCEDURE (CONT'D):

- b. Connect one meter test lead to Stator Wire No. 2, the other test lead to Stator lead No. 11. The meter should read "Infinity".
- c. Connect one VOM test lead to Stator lead No. 2 the other test lead to Stator lead No. 33. "Infinity" should be indicated.

RESULTS:

1. If the Stator excitation (DPE) windings are open or shorted, replace the Stator assembly.
2. If the excitation windings are good, go to Test 8.

Test 7- Test Brushes & Slip Rings

DISCUSSION:

Brushes and slip rings are made of special materials that will provide hundreds of hours of service with little wear. However, when the generator has been idle for some time, an oxide film can develop on the slip rings. This film acts as an insulator and impedes the flow of excitation current to the Rotor.

If Test 3 resulted in less than one-half rated output voltage, it is possible that the brushes and slip rings are at fault.

PROCEDURE:

1. Gain access to the brushes and slip rings.
2. Remove Wire No. 4 (Red) from the positive (+) brush.
3. Remove the ground wire (0F) from the negative (-) brush.
4. Remove the brush holder, with brushes.
5. Inspect the brushes for excessive wear, damage, cracks, chipping, etc.
6. Inspect the brush holder, replace if damaged.
7. Inspect the slip rings.
 - a. If slip rings appear dull or tarnished they may be cleaned and polished with fine sandpaper. **DO NOT USE ANY METALLIC GRIT TO CLEAN SLIP RINGS.**
 - b. After cleaning slip rings, blow away any sandpaper residue.

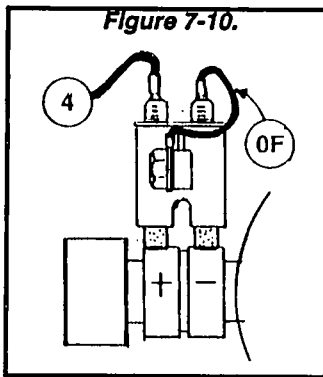

RESULTS:

1. Replace bad brushes. Clean slip rings, if necessary.
2. If brushes and rings are good, go to Test 11.

Test 8- Check Sensing Leads

DISCUSSION:

The Voltage Regulator "regulates" excitation current flow to the Rotor by electronically comparing actual (sensing) voltage to a pre-set reference voltage. The actual (sensing) voltage is delivered to the Regulator via Wires 11S and 22S.

If an open circuit exists in sensing leads 11S or 22S, the normal reaction of an unprotected Regulator would be to increase the excitation current to the Rotor, in an effort to increase the actual AC output voltage. This would result in a "full field" condition and an extremely high AC output voltage.

To protect the system against such a high AC output voltage, the Voltage Regulator on NP and Q-Series units will shut down if sensing voltage signals are lost.

If the regulator shuts down, the generator's AC output voltage will decrease to a value that is commensurate with the Rotor's residual magnetism (about 5-12 VAC).

PROCEDURE:

1. Inspect Wires 11S and 22S where they connect to the Voltage Regulator terminals. Make sure they are properly connected.
2. Disconnect Wires 11S and 22S from the Regulator.
3. Set a VOM to its "Rx1" scale and zero the meter.
4. Connect the meter test leads across Wires 11S and 22S. The meter should indicate Stator power winding resistance (see Test 12).

RESULTS:

1. Repair, reconnect or replace sensing leads 11S and 22S as necessary.
2. If the sensing leads are good, go on to Test 9.

Figure 7-11. Sensing Leads 11S and 22S

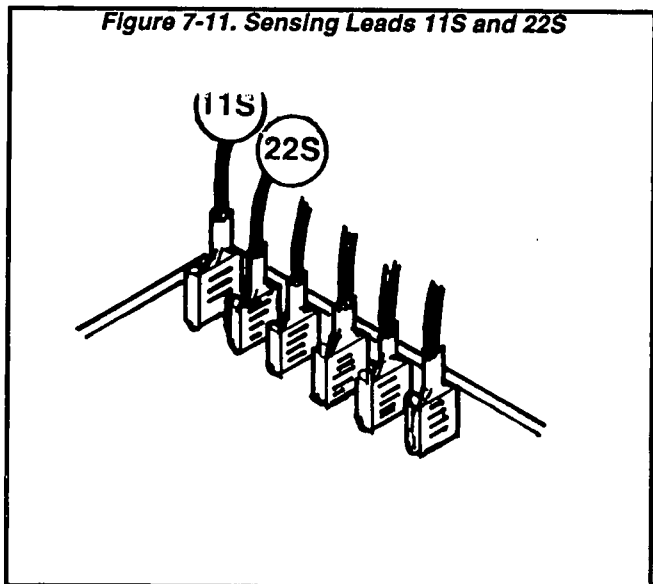

Chapter Seven- DIAGNOSTIC TESTS

Test 9- Check Field Boost

DISCUSSION:

Field boost current (about 9-10 VDC) is delivered to the Rotor only while the engine is being cranked. This current helps ensure that adequate "pickup" voltage is available to turn the Voltage Regulator on and build AC output voltage.

Loss of the field boost function may or may not result in a problem with AC output voltage. If the Rotor's residual magnetism is sufficient to turn the Regulator on, loss of the function may go unnoticed. However, if the Rotor's residual magnetism is not enough to turn the Regulator on, loss of field boost can result in failure of the unit to generate an output voltage.

PROCEDURE:

1. On one end of the large Starter Contactor studs, locate the Starter Motor cable and a single Wire 16 to the Engine Controller circuit board. Disconnect the large Starter Motor cable and the Wire 16 from the stud.
2. Set a VOM to read battery voltage. Then, connect the meter test leads as follows:
 - a. Connect the positive (+) meter test lead to the Wire 4 (Red) terminal of the brush.
 - b. Connect the common (-) meter test lead to the negative (-) or grounded brush terminal.
3. Locate the Wire 16 that was routed from the Starter Contactor to the Engine Controller circuit board.
 - a. Connect this Wire 16 to the large Starter Contactor stud to which the battery cable (Wire 13) is attached.
 - b. The meter should read about 9-10 VDC.
4. If voltage is NOT indicated in Step 3, proceed as follows:
 - a. Connect the meter positive (+) test lead to the Wire 4 terminal of the Voltage Regulator; the common (-) test lead to the Regulator's Wire 0K terminal. Connect Wire 16 from the Engine Controller circuit board to the Starter Contactor's battery cable terminal stud. The meter should read 9-10 VDC.
 - b. Connect the VOM positive (+) test lead to the Wire 4 terminal of the Engine Controller circuit board; the common (-) test lead to the board's Wire 0 terminal. Now, connect Wire 16 from the Engine Controller circuit board to the Starter Contactor's battery cable stud. The meter should read 9-10 VDC.

RESULTS:

1. If the meter indicated 9-10 VDC in Step 3, you may assume the Field Boost circuit is working properly. Go to Test 10.
2. If 9-10 VDC was indicated in Step 4(a), but NOT in Step 3, Wire 4 (Red) between the Regulator and the positive brush is open.

3. If 9-10 VDC is indicated in Step 4(b) but NOT in Step 4(a), Wire 4 between the Engine Controller board and the Voltage Regulator is open.

4. If 9-10 VDC was NOT indicated in Step 4(b), check Wire 16 between the Starter Contactor and the Engine Controller board.

- a. If Wire 16 is bad, replace it.
- b. If Wire 16 is NOT bad, replace the Engine Controller circuit board.

Figure 7-12. The Field Boost Circuit

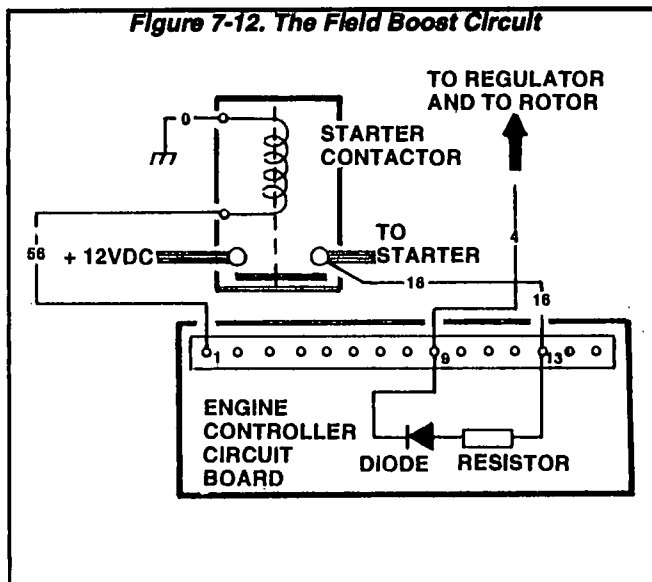

Test 10- Check/Adjust Voltage Regulator

DISCUSSION:

Failure or shutdown of the Voltage Regulator will usually result in loss of excitation current to the Rotor windings. Without excitation current, only residual magnetism will be present in the Rotor and AC output voltage will drop to a value that is commensurate with residual magnetism (approximately 7-12 volts AC).

The Regulator mounts an LED (light emitting diode) which is turned on during operation by sensing voltage (from Wires 11S and 22S). The lamp should be ON during operation.

PROCEDURE:

It is very difficult, if not impossible to test a voltage regulator in the field.

If a problem exists with the generator's AC output, first determine exactly what the problem is. Refer to Chapter Six, "TROUBLESHOOTING FLOW CHARTS". Test the unit in exactly the sequence given in the appropriate FLOW CHART. If all tests in the FLOW CHART have been performed and the cause of the problem has not been determined, it is safe to assume that the cause of the problem is a defective voltage regulator.

Chapter Seven- DIAGNOSTIC TESTS

Test 10- Check/Adjust Voltage Regulator (Continued)

PROCEDURE (CONT'D):

In most cases, failure of the regulator will show itself as low or "residual" AC output frequency. See Problem 2 on Page 19, i.e., "Frequency Good but Voltage Low or Residual". When this is the problem, proceed as follows:

1. Perform Test 3, "Do a Fixed Excitation Test".
 - a. This test involves applying 12 volts DC directly to the Rotor windings, via the brushes and slip rings.
 - b. The test allows the problem to be isolated to specific areas of the excitation circuit.
2. If, with the fixed excitation voltage applied, the unit supplies about one-half rated AC output voltage, the problem could be caused by any of the following:
 - a. Excitation circuit breaker open (Test 5).
 - b. Defective Stator excitation (DPE) winding (Test 6).
 - c. Open or shorted sensing leads to the regulator (Test 8).
 - d. Defective field boost system (Test 9).
 - e. A defective voltage regulator.

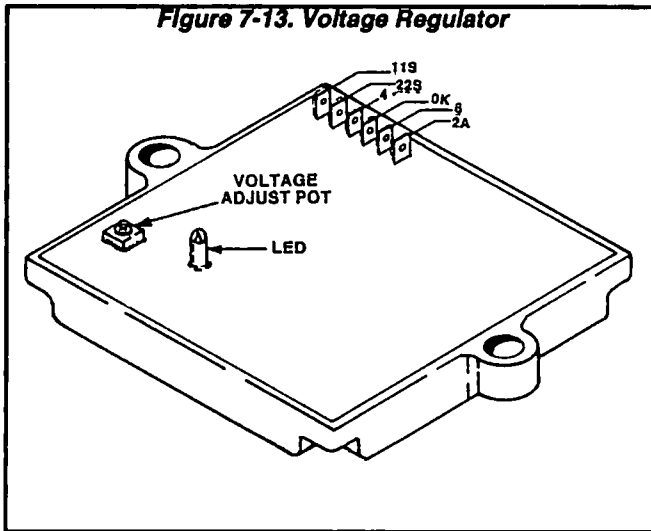

Figure 7-13. Voltage Regulator

Test 11- Check Rotor Assembly

DISCUSSION:

During the "Fixed Excitation" test (Test 3), if AC output voltage did not come up to about one-half rated volts, one possible cause might be a defective Rotor. The Rotor can be tested for an open or shorted condition using a volt-ohm-milliammeter (VOM).

Also see Chapter Three, "INSULATION RESISTANCE TESTS".

PROCEDURE:

To gain access to the brushes and slip rings, remove the upper generator cover. Disconnect Wire 4 (Red) and Wire OF from their respective brushes. Then, test the Rotor as follows:

1. Set a VOM to its "Rx1" scale and zero the meter.
2. Connect the positive (+) meter test lead to the positive (+) slip ring (nearest the Rotor bearing). Connect the common (-) test lead to the negative (-) slip ring. Read the resistance of the Rotor windings, in OHMS.

ROTOR RESISTANCE (Ohms at 20° C.)

| UNIT RATED WATTS | 5000 | 5200 | 5500 | 6600 | 7000 | 7200 |
|------------------|------|------|------|-------|------|------|
| OHMS | 15.5 | 15.5 | 15.5 | 10.81 | 11.3 | 11.3 |

3. Set the VOM to its "Rx1K" or "Rx10,000" scale and zero the meter.
4. Connect the positive (+) meter test lead to the positive (+) slip ring, the common (-) test lead to a clean frame ground (such as the Rotor shaft). The meter should read "Infinity".

RESULTS:

1. Replace the Rotor if it fails the test.
2. If Rotor checks good, go to Test 12.



Figure 7-14. Rotor Assembly

Test 12- Check Stator Power Windings

DISCUSSION:

See "Generator AC Connection System", Page 5.

PROCEDURE:

Gain access to the generator panel interior. Test the Stator power windings, as follows:

1. From main breaker, disconnect Wires 11P and 33.
2. Also disconnect Wires 22P and 44 from the 4-tab ground terminal.
3. Disconnect Wires 11S and 22S from the Voltage Regulator.

Chapter Seven- DIAGNOSTIC TESTS

4. Set a VOM to its "Rx1" scale and zero the meter.
5. Connect the meter test leads across Stator leads 11P and 22P. Normal power winding resistance should be read.
6. Connect the meter test leads across Stator leads 33 and 44. Normal power winding resistance should be read.

| AC POWER WINDING RESISTANCE (Ohms @ 20° C.) | | | | | | |
|---|------|------|------|------|------|------|
| UNIT RATED WATTS | 5000 | 5200 | 5500 | 6600 | 7000 | 7200 |
| OHMS | 0.29 | 0.29 | 0.29 | 0.23 | 0.21 | 0.21 |

7. Now, set the VOM to its "Rx1K" or "Rx10,000" scale and zero the meter.
8. Connect the meter test leads across Stator lead 11P and frame ground. "Infinity" should be read.
9. Connect the meter test leads across Stator lead 33 and frame ground. The reading should be "Infinity".

RESULTS:

1. Replace Stator assembly if the power windings fail the test.
2. If the power windings check good, connect the power winding AC output leads. Make sure the leads are properly connected.

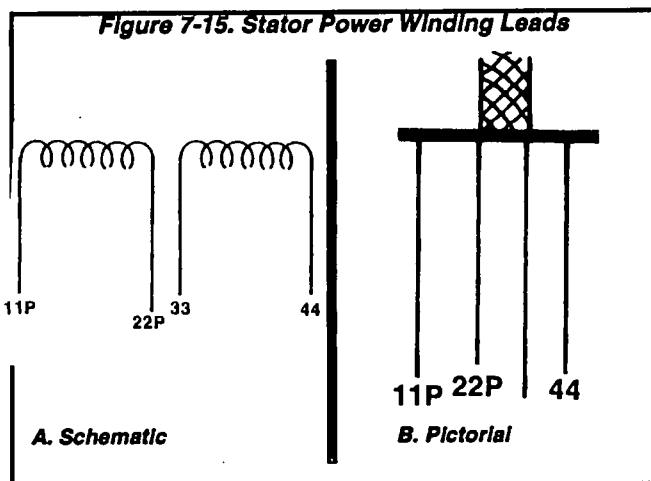

Test 13- Check Main Circuit Breakers

DISCUSSION:

The main circuit breakers on the generator panel must be closed or no output to the load will be available. Depending on the wattage rating, some models are equipped with a 30 amp and a 20 amp main breaker; other models may have two 30 amp

breakers. If the unit has been reconnected for dual voltage output, a 2-pole breaker rated at a different amperage may be installed.

PROCEDURE:

Check that the appropriate main breaker on the generator panel is set to its "ON" (closed) position.

RESULTS:

1. If breaker(s) are "ON" and AC output is still not available, go to Test 14.
2. If breaker(s) are "OFF", reset to the "ON" position and check for AC output.

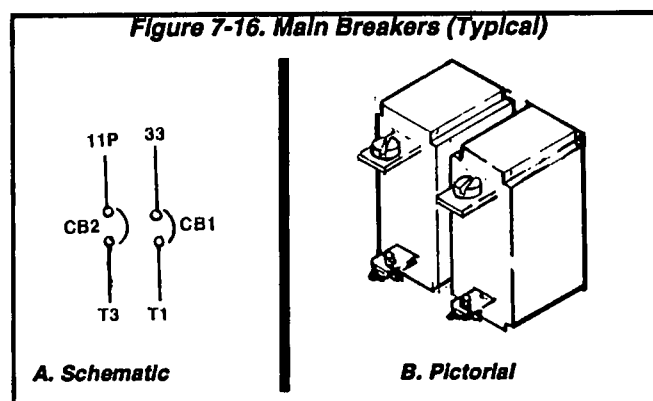

Test 14- Test Main Circuit Breakers

DISCUSSION:

A defective breaker may not be able to pass current even though it is in the "ON" position.

PROCEDURE:

With the breaker "ON" (closed), use a VOM to check for "continuity" across the breaker terminals.

RESULTS:

1. Remove and replace any defective breaker(s).
2. If the breaker tests bad, replace it.

Test 15- Check Load Voltage & Frequency

DISCUSSION:

If engine speed appears to drop off excessively when electrical loads are applied to the generator, the load voltage and frequency should be checked.

PROCEDURE:

Perform this test in the same manner as Test 1, but apply a load to the generator equal to its rated capacity. With load applied check voltage and frequency.

Chapter Seven- DIAGNOSTIC TESTS

Test 15- Check Load Voltage & Frequency (Continued)

Frequency should not drop below about 58 Hertz with the load applied.

Voltage should not drop below about 115 VAC with load applied.

RESULTS:

1. If voltage and/or frequency droop excessively when the load is applied, go to Test 16.
2. If load voltage and frequency are within limits, end tests.

Test 16- Check Load Watts & Amperage

DISCUSSION:

This test will determine if the generator's rated wattage/amperage capacity has been exceeded. Continuous electrical loading should not be greater than the unit's rated capacity.

PROCEDURE:

Add up the wattages or amperages of all loads powered by the generator at one time. If desired, a clamp-on ammeter may be used to measure current flow. See "Measuring Current" on Page 14.

RESULTS:

1. If the unit is overloaded, reduce the load.
2. If load is within limits, but frequency and voltage still drop excessively, complete Test 2, "Check/Adjust Engine Governor". If governor adjustment does not correct the problem, go to Test 17.

Test 17- Check Engine Power

DISCUSSION:

Excessive rpm, frequency and voltage droop may be caused by an engine that has lost power.

PROCEDURE:

Refer to Problem 8 on Page 24 of the "Flow Charts". Start with Test 32 and continue the tests in sequence until the cause of the problem is found (through Test 38, if necessary).

NOTE: Tests 18 through 40 are tests of the engine systems. See Problem 5 through 9 in the "Flow Charts" (Chapter Six).

Test 18- Try Cranking the Engine

DISCUSSION:

If the Fuel Primer Switch on the generator panel is actuated, but the Fuel Pump does not run (priming function doesn't work), perhaps battery voltage is not available.

PROCEDURE:

Hold the Start-Stop Switch at "START". The engine should crank and start.

RESULTS:

1. If the engine cranks normally, but the priming function still doesn't work, go to Test 19.
2. If engine will not crank, go to Test 21. Refer to Problem 6 of Chapter Six.
3. If engine cranks but won't start, go to Problem 7 of Chapter Six.
4. If engine starts hard and runs rough, go to Problem 8 of Chapter Six.

Test 19- Test Primer Switch

DISCUSSION:

A defective primer switch can prevent the priming function from occurring.

Switch failure can also prevent the engine from starting, since the switch is in series with the Wire 14 circuit.

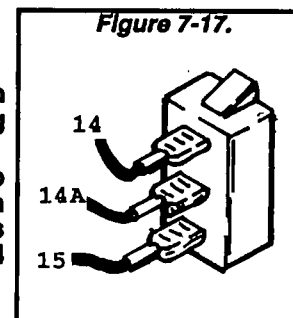

PROCEDURE:

1. Set a VOM to read battery voltage (12 VDC).
2. Connect the positive (+) meter test lead to the Wire 15 terminal of the Primer Switch, the common (-) terminal to frame ground. The meter should indicate battery voltage.
3. Connect the meter positive (+) test lead to the Wire 14A terminal of the Primer Switch, the other test lead to frame ground.
 - a. With the Primer Switch NOT actuated, no voltage should be indicated.
 - b. Actuate the switch to its "PRIME" position and the meter should read battery voltage.
4. Set the meter to its "Rx1" scale and zero the meter.
 - a. Connect the meter test leads across the Wires 14 and 14A terminals of the Switch.
 - b. With the switch NOT actuated, the meter should read "continuity".

RESULTS:

1. If battery voltage is not indicated in Step 2, check Wire 15 between the Primer Switch and the 15 amp fuse for open condition.
2. If battery voltage is indicated in Step 2 but not in Step 3, replace the Primer Switch.
3. If the meter reads other than "continuity" in Step 4, replace the Primer Switch.
4. If the Primer Switch checks good, go to Test 20.

Chapter Seven- DIAGNOSTIC TESTS

Test 20- Check Fuel Pump

DISCUSSION:

An Inoperative Fuel Pump will (a) prevent the priming function from working and (b) prevent the engine from starting.

PROCEDURE:

1. Set a VOM to read battery voltage (12 VDC).
2. Connect the positive (+) meter test lead to the Wire 14A terminal (center terminal) of the primer switch, the other test lead to frame ground.
3. Hold the Primer Switch to its "PRIME" position.
 - a. The meter should read battery voltage.
 - b. The Fuel Pump should operate.

RESULTS:

Replace Fuel Pump If it does not operate.

Figure 7-18. Electric Fuel Pump

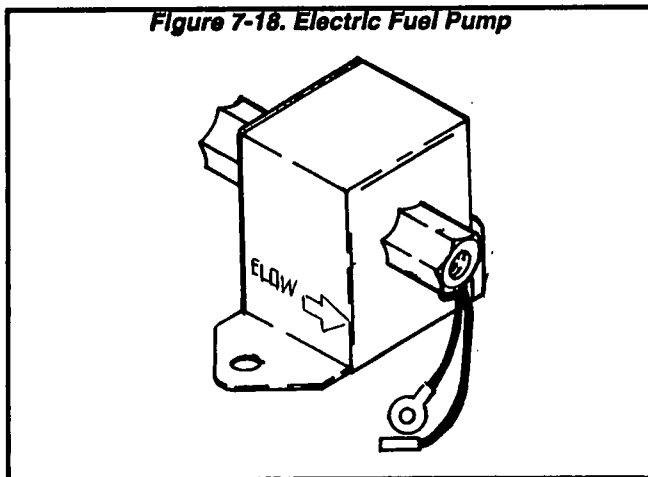

Test 21- Check 15 Amp Fuse

DISCUSSION:

If the panel-mounted 15 amp Fuse (F1) has blown, engine cranking will not be possible.

Figure 7-19.

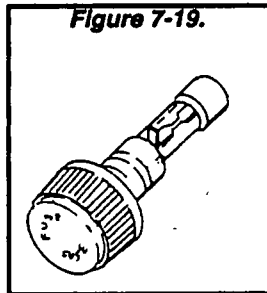

PROCEDURE:

Push in on fuse holder cap and turn counter-clockwise. Then, remove the cap with fuse. Inspect the Fuse.

RESULTS:

If the Fuse element has melted open, replace the Fuse. If Fuse is good, go to Test 22.

Test 22- Check Battery & Cables

DISCUSSION:

If the engine won't crank or cranks too slowly, the battery may be weak or discharged. See "Battery" on Page 17.

PROCEDURE:

1. Inspect the battery cables and battery posts or terminals for corrosion, tightness.
2. Use a battery hydrometer to test the battery for (a) state of charge and (b) condition. Follow the hydrometer manufacturer's instructions carefully.

RESULTS:

1. Clean battery posts and cables as necessary. Make sure battery cables are tight.
2. Recharge the battery, if necessary.
3. Replace the battery, if necessary.
4. If battery is good, but engine will not crank, go to Test 23.

Test 23- Check Power Supply to Circuit Board

DISCUSSION:

If battery voltage is not available to the circuit board, engine cranking and running will not be possible.

If battery voltage is available to the board, but no DC output is delivered to the board's Wire 56 terminal while attempting to crank, either the circuit board is defective or the Start-Stop Switch has failed.

This test will determine if battery voltage is available to the Engine Controller circuit board. Test 24 will check the Start-Stop Switch. Test 25 will check the DC power supply to the circuit board's Wire 56 terminal (Receptacle J1, Pin 1).

PROCEDURE:

1. On the Engine Controller circuit board, locate Terminal J3 to which Wire 15 connects.
2. Set a VOM to read battery voltage. Connect the meter test leads across circuit board Terminal J3 and frame ground. The meter should read battery voltage.

RESULTS:

1. If battery voltage is NOT indicated, check Wire 13 between Starter Contactor and 15 amp Fuse, Wire 15 between the Fuse and the Battery Charge Rectifier, and Wire 15 between the Battery Charge Rectifier and the Engine Controller circuit board. Repair, reconnect or replace bad wire(s) as necessary.
2. If battery voltage is indicated but engine will not crank, go to Test 24.

Chapter Seven- DIAGNOSTIC TESTS

Test 24- Check Start-Stop Switch

DISCUSSION:

Engine cranking and startup is initiated when Wire 17 from the Engine Controller board is connected to frame ground by setting the Start-Stop Switch to "START".

Engine shutdown occurs when circuit board Wire 18 is connected to frame ground by the Start-Stop Switch.

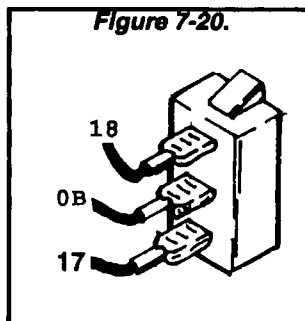

A defective Start-Stop Switch can result in (a) failure to crank and/or (b) failure to shut down when the Switch is set to "STOP".

PROCEDURE:

1. Set a VOM to its "Rx1" scale and zero the meter.
2. Inspect the ground Wire 0B, between the Start-Stop Switch and the grounding terminal. Use the VOM to check the wire for continuity.
3. Disconnect Wire 17 from its Switch terminal and connect it to frame ground. The engine should crank.

RESULTS:

1. Repair, reconnect or replace Wire 0B (between Start-Stop Switch and grounding terminal) as necessary.
2. If engine cranks when Wire 17 is grounded, but will not crank when the Switch is set to "START", replace the Start-Stop switch.
3. If engine will not crank when Wire 17 is grounded, proceed as follows:
 - a. Use a jumper wire to connect the circuit board's Wire 17 terminal to ground. If engine does NOT crank, replace the Engine Controller board.
 - b. If engine cranks now, but would not crank in Step 3 of the procedure, check Wire 17 between the circuit board and Start-Stop Switch.

Test 25- Check Power Supply to Wire 56

DISCUSSION:

If battery voltage is available to the Engine Controller board, but no DC voltage is delivered to Wire 56 when the Start Switch is set to "START", check the Start-Stop Switch as was done in the previous test. Then, check to see if the circuit board is delivering battery voltage to the Wire 56 terminal. If power is available to the circuit board, but no power is available to Wire 56 for cranking, the circuit board must be defective.

PROCEDURE:

1. Set a VOM to read battery voltage (12 VDC).
2. Disconnect Wire 56 from its Starter Contactor terminal.
3. Connect the meter positive (+) test lead to Wire 56, just disconnected. Connect the other test lead to frame ground. No voltage should be indicated.
4. Actuate the Start-Stop Switch to its "START" position. The meter should indicate battery voltage.

RESULTS:

1. If battery voltage was available to the circuit board in Test 24, but is not available to Wire 56 in this test, replace the circuit board.
2. If battery voltage is available to Wire 56 but engine does not crank, go to Test 26.

Test 26- Check Starter Contactor

DISCUSSION:

If battery voltage is available to the Wire 56 circuit, but engine won't crank, one possible cause of the problem is a failed Starter Contactor.

PROCEDURE:

Connect a jumper cable across the two large terminal studs of the Starter Contactor. The engine should crank.

RESULTS:

1. If engine cranks in this test, but would not crank in Test 25, remove and replace the Starter Contactor.
2. If engine does not crank in this test, go to Test 27.

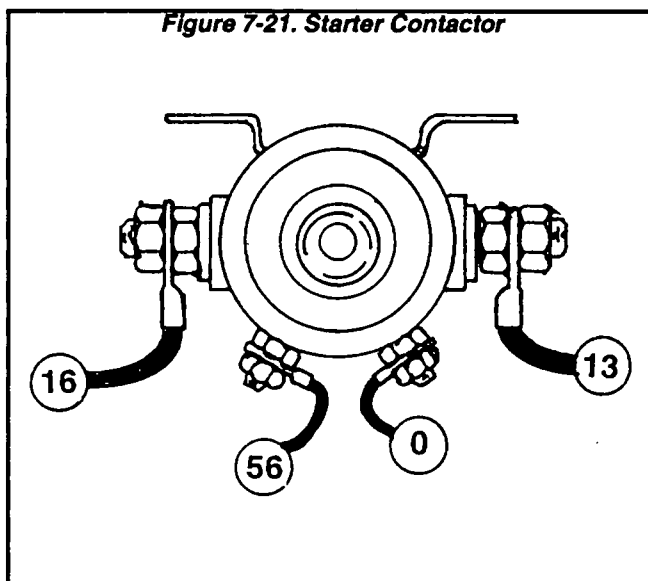

Chapter Seven- DIAGNOSTIC TESTS

Test 27- Check Starter Motor

DISCUSSION:

If the engine will not crank, the Starter Motor may have failed. This test will check that possibility.

PROCEDURE:

The battery should have been checked prior to this test and should be fully charged.

Set a VOM to read battery voltage (12 VDC). Connect the meter positive (+) test lead to the cable connection on the Starter Motor. Connect the common (-) test lead to the Starter Motor frame.

Set the Start-Stop Switch to its "START" position and observe the meter. Meter should indicate battery voltage, Starter Motor should operate and engine should crank.

RESULTS:

If battery voltage is indicated on the meter but Starter Motor did not operate, replace the Starter Motor.

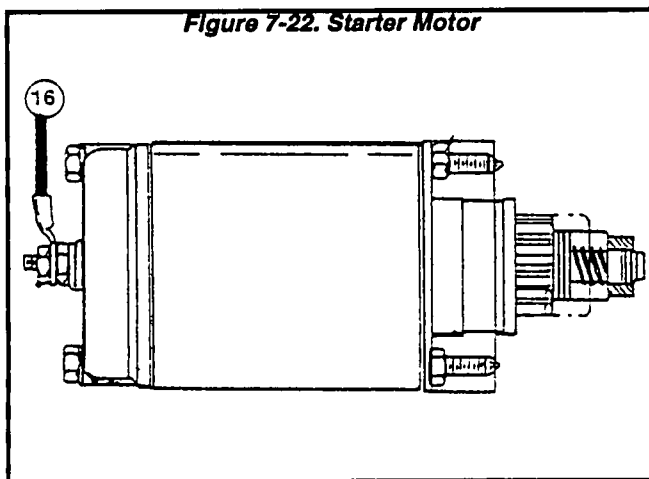

Figure 7-22. Starter Motor

Test 28- Check Fuel Supply

DISCUSSION:

If the engine cranks but won't start, don't overlook the obvious. The fuel supply may be low. Many RV generator installations "share" the fuel tank with the vehicle engine. When such is the case, the installer may have used a generator fuel pickup tube that is shorter than the vehicle engine's pickup tube. Thus, the generator will run out of gas before the vehicle engine.

PROCEDURE:

Check fuel level in the supply tank.

RESULTS:

1. If necessary, replenish fuel supply.
2. If fuel is good, go to Test 29.

Test 29- Check Wire 14 Power Supply

DISCUSSION:

When the engine is cranked, Engine Controller circuit board action must deliver battery voltage to the Wire 14 circuit or the engine will not start. This is because the Wire 14 circuit operates the Fuel Pump.

NOTE: On "Q70" generators, the Wire 14 circuit also opens a fuel solenoid on the carburetor.

PROCEDURE:

Inside the generator panel, locate the 4-tab terminal connector (Figure 7-23). Then, proceed as follows:

1. Set a VOM to read battery voltage (12 VDC).
2. Connect the meter positive (+) test lead to the 4-tab terminal connector, the common (-) test lead to frame ground.
3. Crank the engine and the meter should read battery voltage.

RESULTS:

1. If the meter indicated battery voltage, go to Test 30.
2. If battery voltage was NOT indicated, check Wire 14 between the 4-tab connector and the Engine Controller circuit board.
 - a. Repair, reconnect or replace Wire 14 as necessary.
 - b. If Wire 14 is good, replace the Engine Controller circuit board.

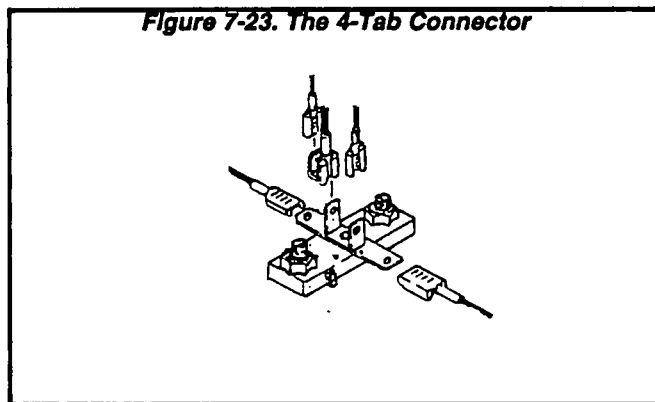

Figure 7-23. The 4-Tab Connector

Test 30- Test Fuel Pump

See Test 20, "Check Fuel Pump Operation". Replace Pump, if bad. If Pump is good, go to Test 31 (Q70G units only) or to Test 32 for other units.

Test 31- Check Fuel Solenoid

DISCUSSION:

This test applies only to "Q70G" models which have a Fuel Solenoid on their carburetor.

Chapter Seven- DIAGNOSTIC TESTS

Test 31- Check Fuel Solenoid (Continued)

DISCUSSION (CONT'D):

If the Fuel Solenoid fails to open, the engine will not start.

PROCEDURE:

Set the Start-Stop Switch to "START". The Fuel Solenoid should actuate.

RESULTS:

1. Replace the Fuel Solenoid, if bad.
2. If Solenoid operates, go to Test 32.

Test 32- Check Ignition Spark

DISCUSSION:

A problem in the engine ignition system can cause any of the following:

- Engine will not start.
- Engine starts hard, runs rough.

A commercially available spark tester may be used to test the engine ignition system. The procedure is basically the same for both the V-Twin engine and single cylinder engines.

PROCEDURE:

1. Disconnect the high tension lead from one spark plug.
2. Attach the high tension lead to the spark tester terminal.
3. Ground the spark tester clamp by attaching to the cylinder head.
4. Crank the engine rapidly. Engine must be cranking at 350 rpm or more. If spark jumps the tester gap, you may assume the ignition system is working properly.
5. For V-Twin engine, repeat the above for the second cylinder.
6. To determine if an engine miss is ignition related, connect the spark tester in series with the high tension lead and the spark plug. Then, start the engine. If spark jumps the tester gap at regular intervals, but the engine miss continues, the problem must be in the spark plug or fuel system.
7. **V-Twin Engine:** To check for a fouled spark plug, short one spark plug to ground and listen for speed drop. If no drop in speed, the spark plug is fouled or cylinder is not functioning.

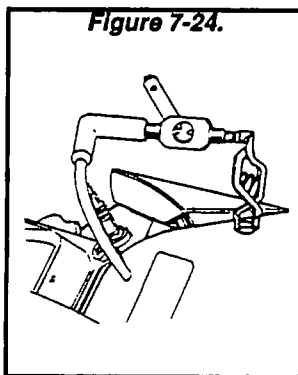
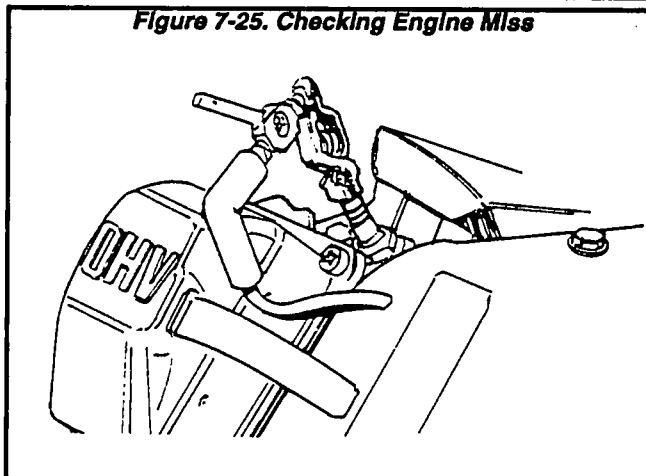

Figure 7-24.

Figure 7-25. Checking Engine Miss



RESULTS:

1. If no spark or if engine miss is apparent, go to Test 34.
2. If ignition spark is good, go to Test 33.

Test 33- Check Spark Plug

DISCUSSION:

During Test 32, if spark jumped the tester gap, the ignition system must be functioning properly. However, if the engine misses the spark plug itself may be fouled.

PROCEDURE:

Remove spark plug(s). Clean with a commercial solvent. **DO NOT BLAST CLEAN SPARK PLUGS.** Replace spark plug(s) if badly fouled, if ceramic is cracked, or if badly worn or damaged. Set gap to 0.030 inch (0.76mm). Use a Champion RC12YC (or equivalent) replacement spark plug on both the V-Twin and the GN-360 engine.

RESULTS:

1. Clean and regap or replace spark plug(s) as necessary.
2. If spark plug is good, go to Test 36.

Test 34- Check Ignition Power Supply

DISCUSSION:

If ignition spark did not occur in Test 32, it is possible that power is not available to the engine ignition module(s). Power for ignition is delivered to the ignition module(s) from the Engine Controller circuit board, via Wire(s) 18A. If the engine cranks normally but no power is available, either the applicable Wire 18A is open or the Engine Controller circuit board is bad.

Chapter Seven- DIAGNOSTIC TESTS

PROCEDURE:

1. Set a VOM to read battery voltage.
2. Inside the control panel, locate the Engine Controller circuit board's 15-pin connector plug.
3. For twin cylinder engine, proceed as follows:
 - a. Connect the positive meter test lead to Terminal 4 of the 15-pin connector; connect the common (-) test lead to Terminal 12 (ground).
 - b. Crank the engine. The meter should indicate battery voltage.
 - c. Now, connect the meter positive test lead to Terminal 5 of the 15-pin connector; the common (-) test lead to Terminal 12 (ground). Again, crank the engine and the meter should indicate battery voltage.
4. For single cylinder engine, connect the positive meter test lead to Terminal 4 of the 15-pin connector; the common (-) test lead to Terminal 12 (ground). Crank the engine and the meter should read battery voltage.

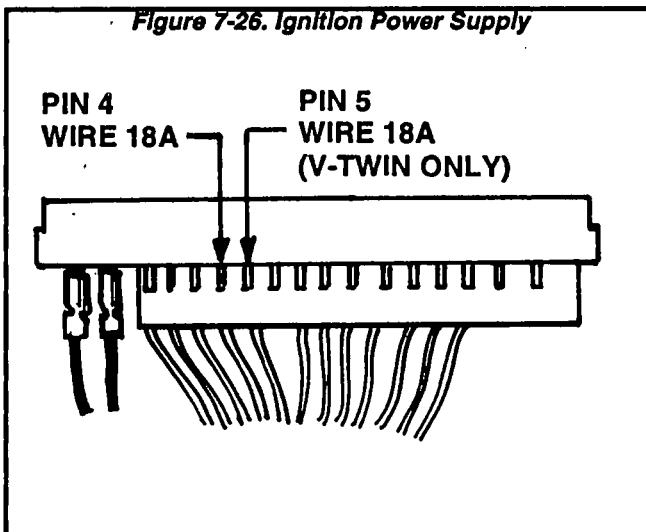

RESULTS:

1. If Ignition power supply is good, go to Test 35.
2. If battery voltage is not indicated, replace the Engine Controller circuit board.

Test 35- Test Ignition System

DISCUSSION:

Instructions on the servicing and testing of the twin cylinder engine ignition system can be found in "Service Manual- V-Twin OHV Horizontal and Vertical Shaft Engine" (Manual Part No. 81134).

RESULTS:

Repair or replace ignition system parts, as necessary.

Test 36- Check Carburetion

DISCUSSION:

If the engine cranks but will not start, one possible cause of the problem might be the carburetion system.

PROCEDURE:

Before making a carburetion check, be sure the fuel supply tank has an ample supply of fresh, clean gasoline (gasoline fuel system); or an adequate supply of gaseous fuel (for gaseous systems).

Check that all shutoff valves are open and fuel flows freely through the fuel line.

For gasoline system, inspect and adjust the carburetor needle valve.

Make sure the automatic choke operates properly.

If the engine will not start, remove and inspect the spark plug. If the spark plug is wet, look for the following:

- Overchoking.
- Excessively rich fuel mixture.
- Water in fuel.
- Intake valve stuck open.

If the spark plug is dry, look for the following:

- Leaking carburetor mounting gaskets.
- Intake valve stuck closed.
- Inoperative fuel pump.
- Plugged fuel filter(s).

One simple method of determining if fuel is getting to the combustion chamber is to remove the spark plug and pour a small quantity of gasoline into the spark plug hole. Install the plug and crank the engine. If engine fires a few times and then quits, look for the same condition as a dry plug.

If the engine starts hard or will not start, look for the following:

- Physical damage to the AC generator. Check the Rotor for contact with the Stator.
- A loose drive belt can sometimes cause a backlash effect which will counteract cranking effort.
- Stalling under load. Make sure all loads are disconnected or turned off before attempting to crank and start the engine.
- Check that the automatic choke is working properly.

RESULTS:

If problem has not been solved, go to Test 37.

Chapter Seven- DIAGNOSTIC TESTS

Test 37- Check Choke Operation

DISCUSSION:

The automatic choke is active only during cranking. When the Start-Stop Switch is held at "START", a crank relay on the Engine Controller circuit board is energized closed to (a) crank the engine and (b) deliver a cyclic voltage to the Choke Solenoid via Wire No. 90. The Choke Solenoid will be pulled in for about one second, then deactivate for about two seconds. This cyclic choking action will continue as long as the engine is being cranked.

PROCEDURE:

Operational Check: Crank the engine. While cranking, the choke solenoid should pull in about every 2 seconds (1 second ON, 2 seconds OFF). If the choke solenoid does not pull in, try adjusting the choke as follows.

Pre-Choke Adjustment: See Figure 7-28. With the SOLENOID CHOKE not actuated, the carburetor CHOKE PLATE should be approximately 1/8 inch from its full open position. If necessary, use needle nose pliers to bend the tip of the BI-METAL until the desired setting is obtained.

Choke Solenoid Adjustment: Loosen the screws that retain the SOLENOID CHOKE to its bracket. Slide the SOLENOID CHOKE in the slotted holes of the bracket to adjust axial movement of the SOLENOID PLUNGER. Adjust SOLENOID PLUNGER movement until, with the carburetor CHOKE PLATE closed, the SOLENOID CHOKE is bottomed in its coil (plunger at full actuated position). With the CHOKE PLATE closed and the plunger bottomed in its coil, tighten the two screws.

RESULTS:

1. If Choke operation is good, go to Test 38.
2. If necessary, adjust or repair choke parts.

Test 38- Check Engine

GENERAL:

Most engine problems may be classified as one or a combination of the following:

- Will not start.
- Starts hard.
- Lack of power.
- Runs rough.
- Vibration.
- Overheating.
- High oil consumption.

Figure 7-27. Automatic Choke Circuit

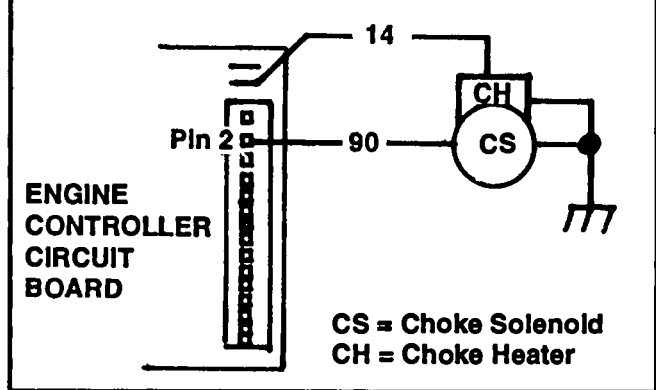
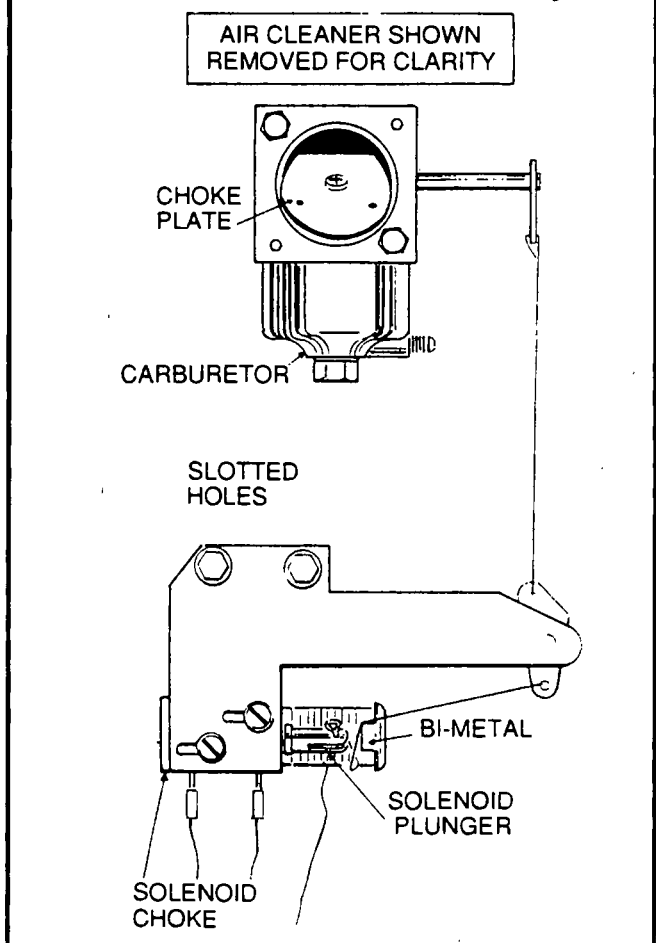

Figure 7-28. Automatic Choke Assembly



CYLINDER BALANCE TEST:

If the engine (a) starts hard, (b) runs rough, or (c) misses or lacks power, perform a cylinder balance test to determine if both cylinders are operating at their full capacity.

Chapter Seven- DIAGNOSTIC TESTS

The cylinder balance test applies only to twin cylinder engines. Perform the test as follows:

1. Connect a commercially available spark tester in series with the high tension spark plug leads and the spark plugs.
2. With engine running at governed no-load speed, check spark across the two spark testers.

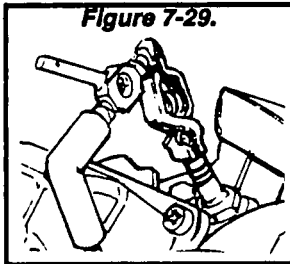

Figure 7-29.

NOTE: If spark is equal at both spark testers, the problem is NOT ignition related. A spark miss will be readily apparent.

3. Note the AC frequency reading of the generator. No-load frequency should be about 61-63 Hertz.
4. Use the screwdriver with insulated handle to ground out one cylinder, by contacting alligator clip on tester and a clean ground on the engine. Note the frequency (rpm) loss.
5. Remove the screwdriver and let the engine clear itself. Then, ground the other spark plug and note the frequency (rpm) loss.
 - a. If the difference between the two cylinders is less than 1-1/4 Hertz (75 rpm), the amount of work each cylinder is doing may be considered equal.
 - b. If the frequency (rpm) loss between two cylinders is less than 1-1/4 Hertz (75 rpm) and the engine runs poorly, the problem is common to both cylinders. Things that affect BOTH cylinders are (carburetion), (b) crankcase vacuum, (c) ignition.
 - c. If the frequency between the two cylinders is greater than 1-1/4 Hertz (75 rpm), the cylinder with the lowest frequency (rpm) is the weakest of the two. Look to that cylinder for a problem. Things that affect one cylinder are (a) spark plug, (b) leaking spark plug wire, (c) head gasket, (d) intake manifold, (e) valves, (f) rings, (g) piston, or (h) cylinder.

NOTE: The cylinder balance test will also detect a cylinder that is not functioning. When grounding one cylinder, no rpm loss will be noted. When the other cylinder is grounded, the engine will shut down.

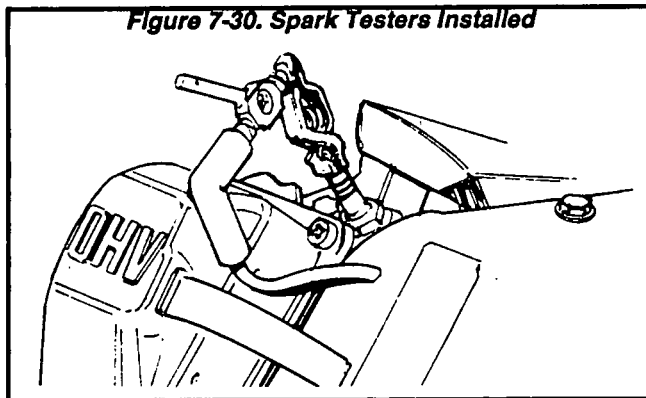

Figure 7-30. Spark Testers Installed

CHECK IGNITION:

See Test 32.

CHECK CARBURETION:

See Test 36.

CHECK COMPRESSION:

Refer to "Service Manual- V-Twin OHV Horizontal and Vertical Shaft Engine" (Manual Part No. 81134).

Test 39- Check Oil Pressure Switch

DISCUSSION:

Also see "Operational Analysis" on Pages 15 and 16. The Low oil Pressure Switch is normally-closed, but is held open by engine oil pressure during cranking and startup. Should oil pressure drop below a safe level, the switch contacts will close to ground the Wire 85 circuit. Engine controller board action will then initiate an automatic shutdown.

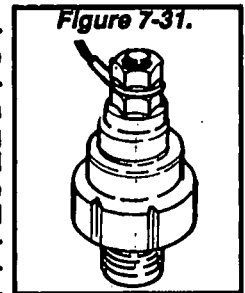

Figure 7-31.

If the switch falls closed, the engine will crank and start but will then shut down after a few seconds.

If the switch falls open, low oil pressure will not result in automatic shutdown.

PROCEDURE:

1. Check engine oil level. If necessary, replenish oil level to the dipstick "FULL" mark.
2. Remove the protective boot from the switch terminal.
3. Disconnect the wires from the switch terminal.
4. Set a VOM to its "Rx1" scale and zero the meter.
5. Connect the meter test leads across the switch terminal and frame ground, with engine shut down. The meter should read "continuity". A small amount of resistance is acceptable.
6. Crank the engine. Oil pressure should open the switch contacts at some point while cranking and starting. Meter should then indicate "Infinity".
7. When engine starts, hold Wire 85, previously disconnected from the Oil Pressure Switch terminal, into firm contact with frame ground. The engine should shut down.

RESULTS:

1. In Step 5, if "continuity" is not indicated, replace the switch.
2. In Step 6, if "Infinity" is NOT indicated, replace the switch.
3. In Step 7, if shutdown does NOT occur, check Wire 85 between switch and circuit board for open condition. If Wire 85 is NOT open, replace the Engine Controller circuit board.

Chapter Seven- DIAGNOSTIC TESTS

Test 39- Check Oil Pressure Switch (Continued)

NOTE: If the engine shuts down with Wire 85 connected to the Oil Pressure Switch, but does not shut down when Wire 85 is disconnected from the switch, the switch may be functioning normally. Remove the switch and install a direct reading oil pressure gauge in its place. If oil pressure is below about 8-10 psi with engine running, check engine for failure.

Test 40- Test Oil Temperature Switch

DISCUSSION:

If the engine cranks, starts and then shuts down, one possible cause of the problem may be a high oil temperature condition. Protective shut-down is a normal occurrence if oil temperature is greater than approximately 265° F. (129° C.).

PROCEDURE:

1. Remove Wire 85 from Oil Temperature Switch terminal and try a start. If engine starts and runs now, but shuts down when Wire 85 is connected to the switch terminal, the following possibilities exist:

- a. Oil temperature is too high.
- b. The oil temperature switch has failed closed or is shorted to ground.

2. Remove the switch and place its sensing tip into oil (Figure 7-33). Place a thermometer into the oil.
3. Connect the test leads of a VOM across the switch terminals. The meter should read "Infinity".
4. Heat the oil. When oil temperature reaches approximately 260°-270° F. (128°-130° C.), the switch contacts should close and the meter should read "continuity".

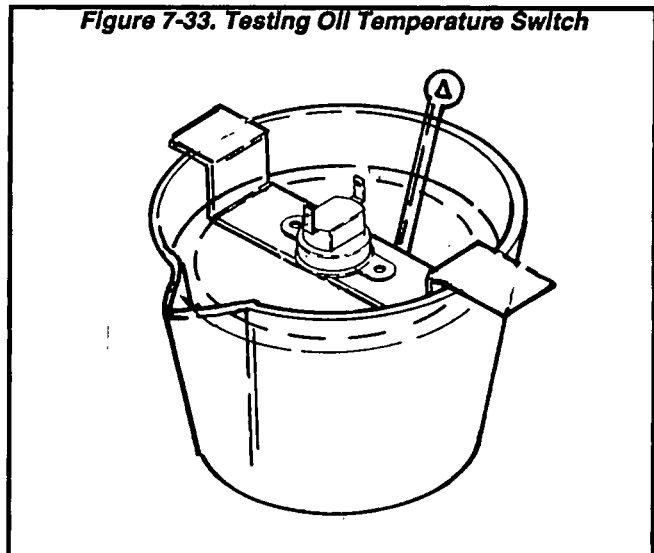
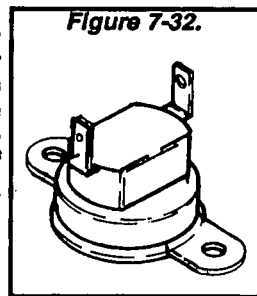

Chapter Eight- ASSEMBLY (V-TWIN ENGINE UNITS)

General

The vertical shaft V-Twin engine and the vertically mounted AC generator are mounted side-by-side to the unit's mounting base. The engine PTO (power takeoff) shaft and the generator Rotor shaft extend downward through openings in the mounting base. An engine pulley is attached to the engine PTO shaft; a generator pulley is attached to the Rotor shaft. A drive belt drives the two pulleys and allows the engine to drive the Rotor at a pre-determined speed.

Generator models covered in this Manual are equipped with a 2-pole Rotor which must be driven at 3600 rpm for 60 Hertz AC output; or 3000 rpm for 50 Hertz AC output. The engine rpm required to drive the Rotor at its proper speed is listed in an "APPLICABLE MODELS & SPECIFICATIONS" chart on Page 1 of this Manual.

Sheet Metal

Figure 8-2 shows the sheet metal that surrounds the twin-cylinder engine. An ENGINE TOP HOUSING (Item 7) encloses an ENGINE FLYWHEEL which is keyed to the engine shaft and retained by an M20-1.50 hex nut and a Belleville washer. The FLYWHEEL provides a cooling air fan and a starter ring gear. Air openings in the ENGINE TOP HOUSING allow the cooling air fan to draw cooling air around the engine.

Carburetor and air cleaner parts are attached to the VALLEY COVER (Item 14).

Air Cleaner, Carburetor & Choke

See Figure 8-3. Carburetor parts are attached to the VALLEY COVER (Item 14 in Figure 8-1).

AC Generator

See Figure 8-4. The generator proper consists of the following major parts:

- Generator Top Housing (Item 12).
- Brush Holder with Brushes (Item 9).
- An Upper Bearing Carrier (Item 6).
- The Stator Assembly (Item 3).
- The Lower Bearing Carrier (Item 1).
- The Rotor Assembly (Item 2).

The Stator is sandwiched between the upper and lower bearing carrier and retained by four Stator Studs (Item 7). The unit is a "2-bearing" type with the Rotor supported on two ball bearings, one in the Upper Bearing Carrier and one in the Lower Bearing Carrier.

Control Panel

Control panel components are shown in Figure 8-4. The following parts are housed in the Control Panel:

- Engine Controller Circuit Board (Item 20).
- The Starter Contactor (Item 29).
- Battery Charge Rectifier (Item 32).
- Excitation Circuit Breaker (Item 41).
- The AC Voltage Regulator (Item 43).
- Main Circuit Breakers (Items 46 and 47).
- The 15 amp Fuse Holder with Fuse (Item 52).
- Start-Stop Switch (Item 54).
- Fuel Primer Switch (Item 55).

Mounting Base and Pulleys

Figure 8-5 shows the engine-generator mounting base (Item 1). The engine and generator pulleys (Items 21 and 22) include blowers which operate in a blower housing (Item 30) to move air and fumes downward and away from the unit. A Slide Pan (Item 81) provides the required air outlet openings and acts as a "floor" for the unit.

Drive belt tension is adjusted by means of two (2) BELT TENSIONING SPRINGS (Item 12), CAPSCREWS (Item 11), SPRING WASHER (Item 13) and FLANGED LOCK NUTS (Item 10). Turning the CAPSCREWS (Item 11) moves the generator LOWER BEARING CARRIER axially on NYLON SLIDES (Item 14), and changes the tension on the DRIVE BELT (Item 23).

The generator's lower bearing carrier is retained to the mounting base by four (4) springs (Item 34).

See Figure 8-1, below. To adjust belt tension, turn the two adjusting bolts until the compressed length of the springs is 5/8 inch (16mm).

To adjust the tension of the four lower bearing carrier springs, turn the adjusting bolts to obtain a compressed spring length of 7/8 inch (22mm).

Figure 8-1. Belt Tension & Generator Springs Adjust

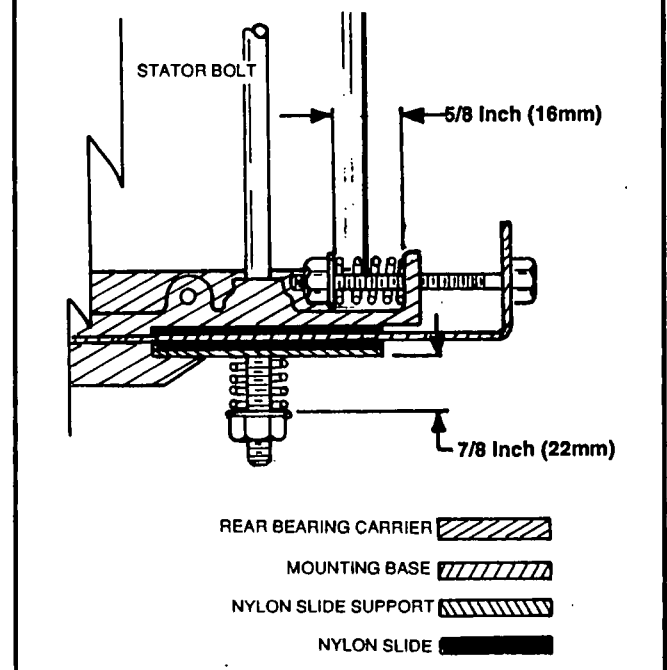

Chapter Eight- ASSEMBLY (V-TWIN ENGINE UNITS)

Figure 8-2. Exploded View of Sheet Metal (Drawing No. 89403)

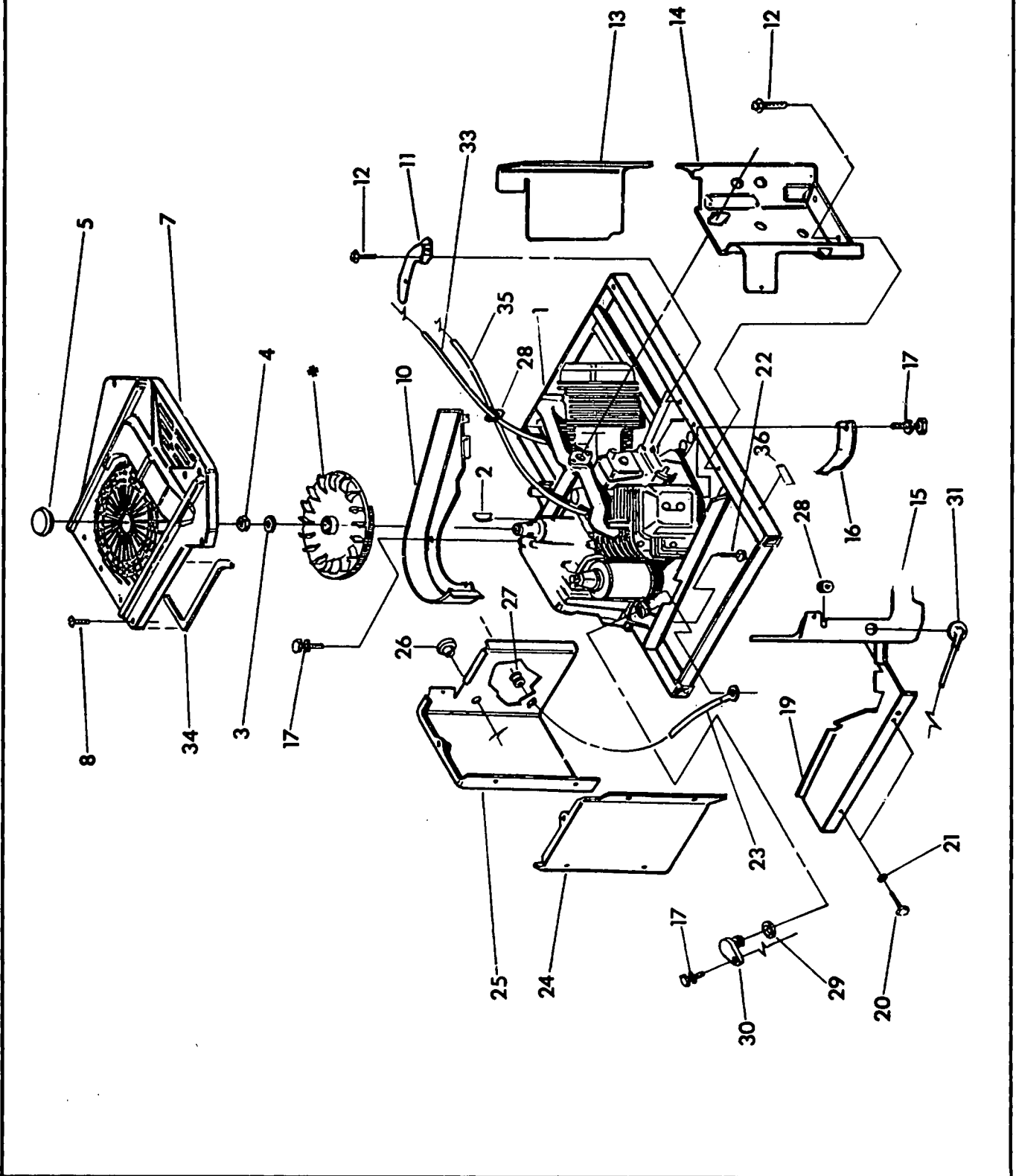

Chapter Eight- ASSEMBLY (V-TWIN ENGINE UNITS)

Parts List for Figure 8-2 (Drawing No. 89403)

| ITEM | QTY | DESCRIPTION | ITEM | QTY | DESCRIPTION |
|------|-----|---------------------------|------|-------|----------------------------------|
| 1 | 1 | Twin Cylinder Engine | 19 | 1 | No. 1 Cylinder Base Cover |
| 2 | 1 | Woodruff Key | 20 | 2 | M8-1.25 x 1.25 Hex Head Capscrew |
| 3 | 1 | Belleville Washer | 21 | 2 | M8 Lockwasher |
| 4 | 1 | M20-1.50 Hex Nut | 22 | 4 | 3/8"-16 x 1-1/4" Screw (Tapfit) |
| 5 | 1 | Flywheel Access Plug | 23 | 1 | Starter Cable (Wire 16) |
| 7 | 1 | Engine Top Housing | 24 | 1 | Starter Cover |
| 8 | 23 | No. 10-24 x 1/2" Screw | 25 | 1 | Crankcase Wrapper |
| 10 | 1 | Flywheel Scroll | 26 | 1 | Snap Bushing |
| 11 | 1 | No. 2 Cylinder Base Cover | 27 | 1 | Rubber Grommet |
| 12 | 9 | M5 x 10mm Screw | 28 | 3 | Rubber Grommet |
| 13 | 1 | No. 2 Cylinder Wrapper | 29 | 1 | O-Ring |
| 14 | 1 | Valley Cover | 30 | 1 | Oil Fill Plug |
| 15 | 1 | No. 1 Cylinder Wrapper | 31 | 2 | Spark Plug Boot |
| 16 | 2 | Barrel Wrapper | 33 | 1 | No. 2 Cylinder Ground Wire |
| 17 | 2 | M6-1.00 x 12mm Capscrew | 34 | 2 ft. | Foam Tape |
| | | | 35 | 1 | No. 1 Cylinder Ground Wire |
| | | | 36 | 1 | Oil Drain Decal |

Chapter Eight- ASSEMBLY (V-TWIN ENGINE UNITS)

Figure 8-3. Exploded View of Air Cleaner, Carburetor & Choke (Drawing No. 93753)

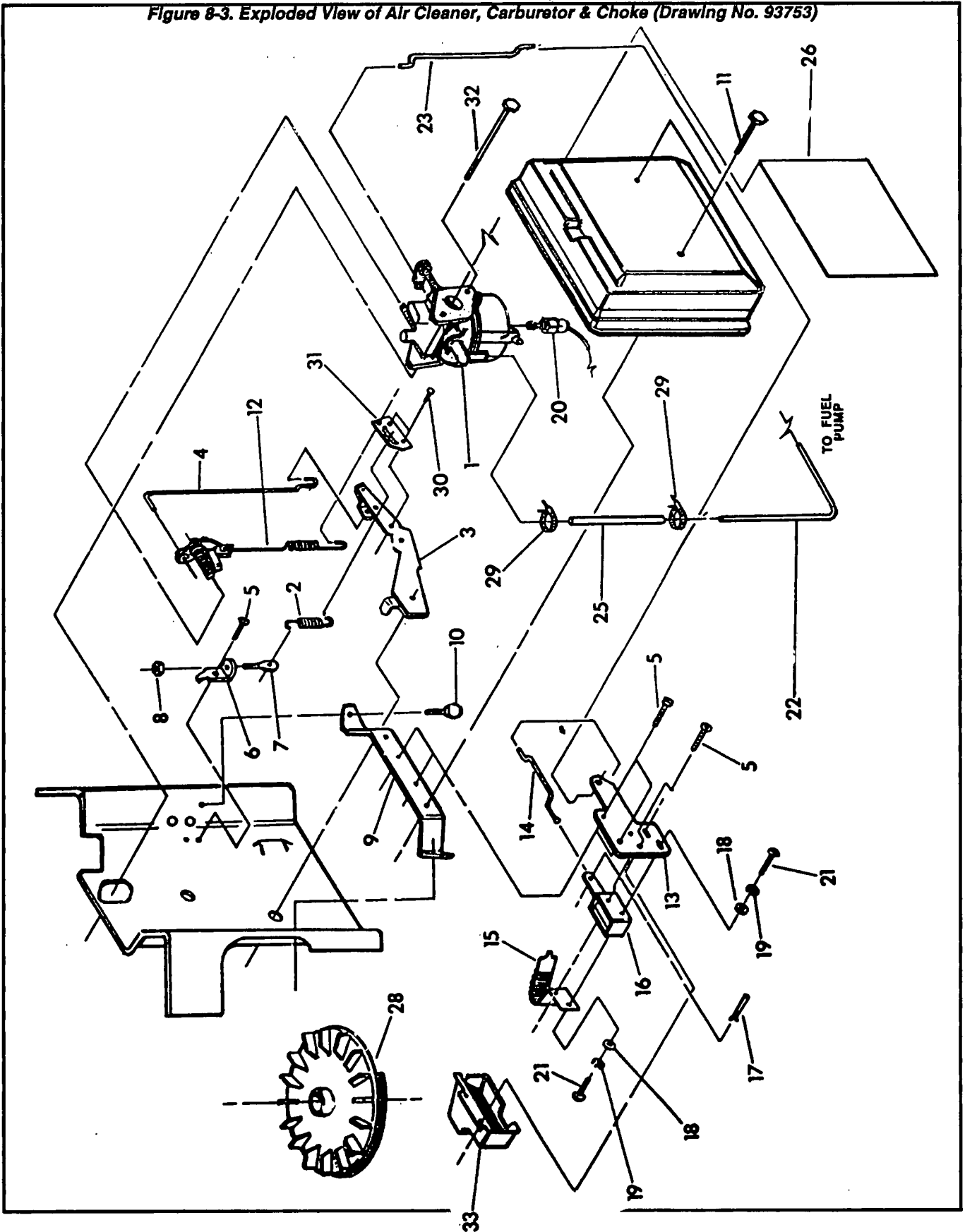

Chapter Eight- ASSEMBLY (V-TWIN ENGINE UNITS)

Parts List for Figure 8-3 (Drawing No. 93753)

| ITEM | QTY | DESCRIPTION | ITEM | QTY | DESCRIPTION |
|------|-----|-----------------------------|------|-----|--|
| 1 | 1 | Carburetor Assembly | 17 | 1 | 3/32" Cotter Pin |
| 2 | 1 | Governor Spring | 18 | 4 | No. 4 Flatwasher |
| 3 | 1 | Governor Lever | 19 | 4 | No. 4 Lockwasher |
| 4 | 1 | Governor to Carburetor Rod | 20 | 1 | Fuel Solenoid (Q70G Only) |
| 5 | 5 | No. 10-32 x 3/8" Screw | 21 | 4 | No. 4-40 x 1/4" Pan Head Screw |
| 6 | 1 | Governor Adjuster Bracket | 22 | 1 | 5/16" ID Fuel Line |
| 7 | 1 | Governor Adjuster Screw | 23 | 1 | Choke Link |
| 8 | 1 | Nylon Hex Lock Nut | 25 | 1 | Fuel Hose |
| 9 | 1 | Air Cleaner Support Bracket | 26 | 1 | Air Cleaner Decal |
| 10 | 2 | M6-1.00 x 12mm Hex Screw | 27* | 1 | Carburetor Overhaul Kit |
| 11 | 2 | M6-1.00 x 25mm Hex Screw | 28 | 1 | Flywheel Assembly |
| 12 | 1 | Anti-Lash Spring | 29 | 2 | Hose Clamp |
| 13 | 1 | Choke Support Bracket | 30 | 2 | 1/8" Rivet |
| 14 | 1 | Choke Control Rod | 31 | 1 | Governor Spring Bracket |
| 15 | 1 | Choke Bi-Metal Assembly | 32 | 2 | M6-1.00 x 93mm Capscrew (Includes Washer) |
| 16 | 1 | Choke Solenoid | 33 | 1 | Choke Coil Cover |

* To order Carburetor Overhaul Kit, specify Part No. 75252.

Chapter Eight- ASSEMBLY (V-TWIN ENGINE UNITS)

Figure 8-4. Exploded View of Generator & Panel (Drawing No. 91664)

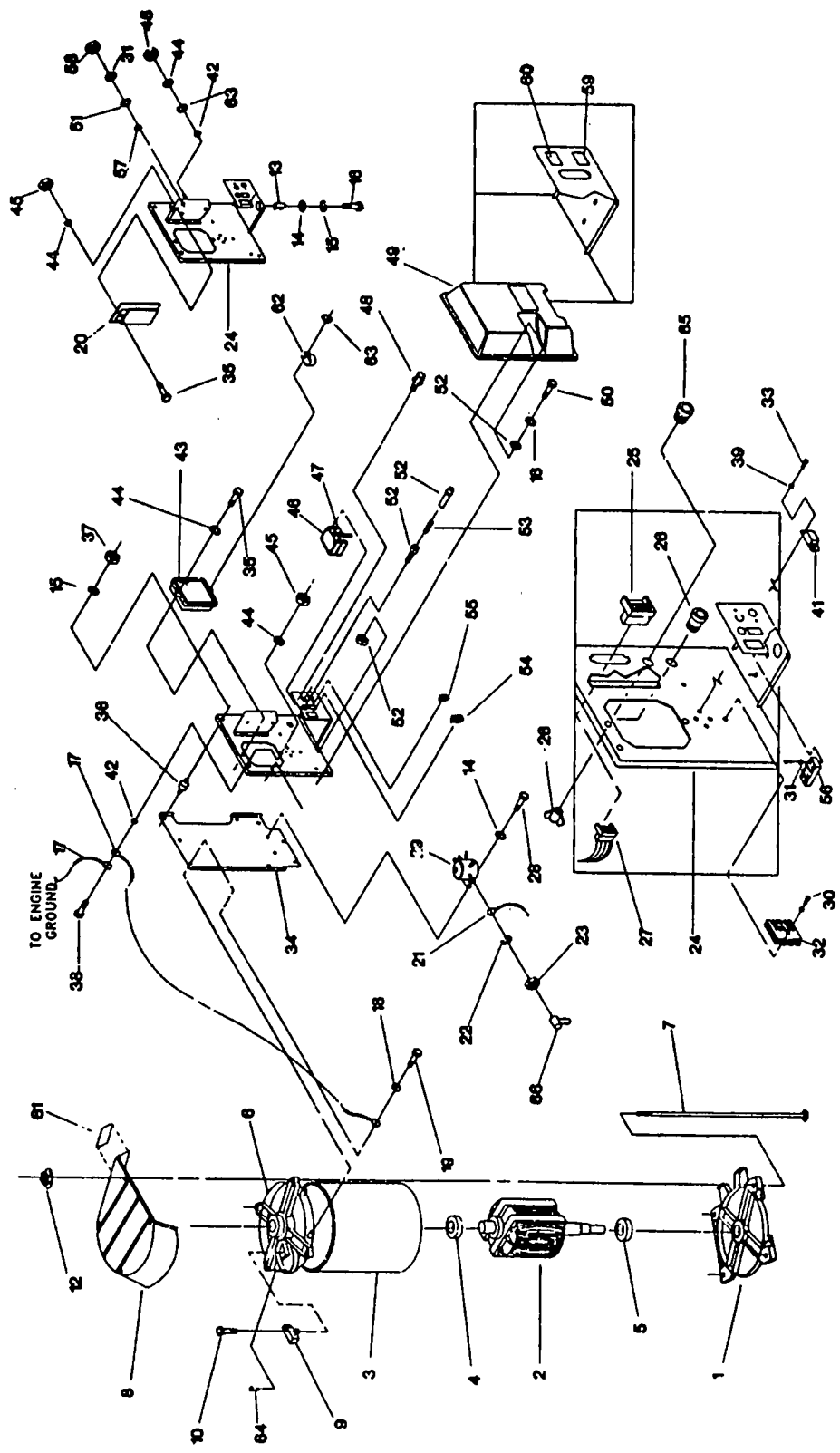

Chapter Eight- ASSEMBLY (V-TWIN ENGINE UNITS)

Parts List for Figure 8-4 (Drawing No. 91664)

| ITEM | QTY | DESCRIPTION | ITEM | QTY | DESCRIPTION |
|------|-----|---------------------------------|------|-----|--|
| 1 | 1 | Lower Bearing Carrier | 33 | 2 | M3-0.50 x 15mm Capscrew |
| 2 | 1 | Rotor Assembly | 34 | 1 | Panel Support Bracket |
| 3 | 1 | Stator Assembly | 35 | 4 | M5-0.80 x 16mm Capscrew |
| 4 | 1 | Rotor Bearing | 36 | 4 | Vibration Mount |
| 5 | 1 | Rotor Bearing | 37 | 4 | M6-1.00 Hex Nut |
| 6 | 1 | Upper Bearing Carrier | 38 | 1 | M5-0.80 x 16mm Capscrew |
| 7 | 4 | Stator Stud | 39 | 2 | M3 Lockwasher |
| 8 | 8 | M8-1.25 Flanged Lock Nut | 41 | 1 | Excitation Circuit Breaker |
| 9 | 1 | Brush Holder | 42 | 2 | M5 Shakeproof Washer |
| 10 | 2 | M5-0.80 x 16mm Screw | 43 | 1 | AC Voltage Regulator |
| 11 | 4 | Nylon Washer | 44 | 6 | M5 Lockwasher |
| 12 | 1 | Generator Top Housing | 45 | 4 | M5-0.80 Hex Nut |
| 13 | 1 | Resistor | 46 | 1 | Main Circuit Breaker |
| 14 | 3 | M6 Flatwasher | 47 | 1 | Main Circuit Breaker |
| 15 | 5 | M6 Lockwasher | 48 | 4 | No. 6-32 Screw (w/Lockwasher) |
| 16 | 1 | M6-1.00 x 60mm Capscrew | 49 | 1 | Panel Cover |
| 17 | 2 | Ground Cable | 50 | 4 | M4-0.70 x 16mm Capscrew (Includes Lockwasher, Flatwasher) |
| 18 | 1 | Lockwasher | 51 | 1 | M4 Flatwasher |
| 19 | 4 | M6-1.00 x 20mm Screw | 52 | 1 | Fuse Holder |
| 20 | 1 | Engine Controller Circuit Board | 53 | 1 | 15 amp Fuse |
| 21 | 1 | Starter Cable | 54 | 1 | Start-Stop Switch |
| 22 | 2 | 5/16" Lockwasher | 55 | 1 | Fuel Primer Switch |
| 23 | 2 | 5/16"-18 Hex Nut | 56 | 1 | Terminal Block |
| 24 | 1 | Panel Sheet Metal | 57 | 1 | M4 Lockwasher |
| 25 | 1 | 4-Tab Connector | 58 | 1 | M4-0.70 Hex Nut |
| 26 | 1 | Connector | 59 | 1 | Circuit Breaker Rating Decal |
| 27 | 1 | Remote Panel Harness | 60 | 1 | Circuit Breaker Rating decal |
| 28 | 2 | M6-1.00 x 12mm Screw | 61 | 1 | Customer Connection Decal |
| 29 | 1 | Starter Contacter | 62 | 1 | Hose Clamp |
| 30 | 3 | M4-0.70 x 16mm Capscrew | 63 | 2 | M5 Flatwasher |
| 31 | 4 | M4 Lockwasher | 64 | 1 | M5 x 10mm Screw |
| 32 | 1 | Battery Charge Rectifier | 65 | 1 | Bushing |
| | | | 66 | 1 | Battery Cable Boot |

Chapter Eight- ASSEMBLY (V-TWIN ENGINE UNITS)

Figure 8-5. Exploded View of Mounting Base & Pulleys (Drawing No. 91663)

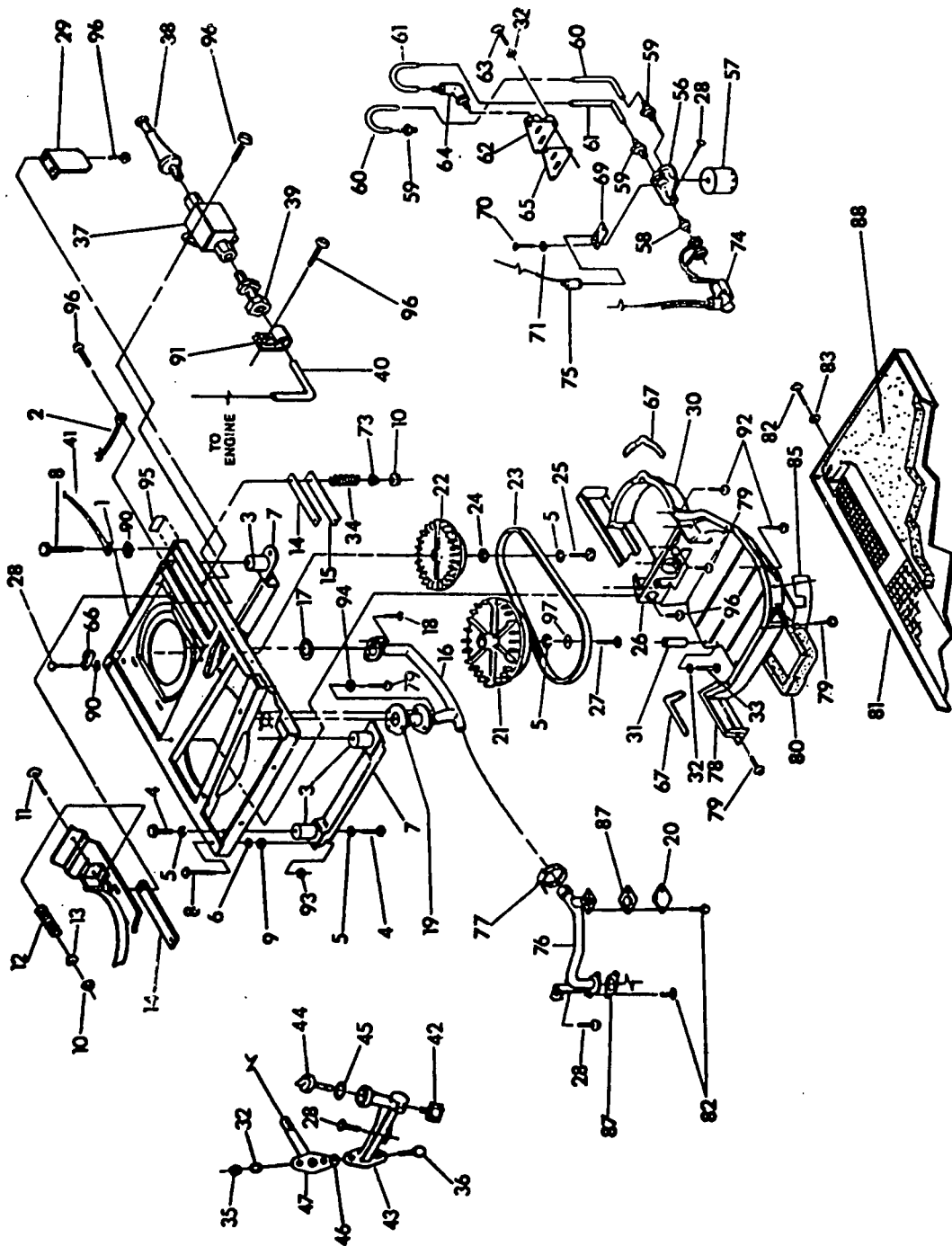

Chapter Eight- ASSEMBLY (V-TWIN ENGINE UNITS)

Parts List for Figure 8-5 (Drawing No. 91663)

| ITEM | QTY | DESCRIPTION | ITEM | QTY | DESCRIPTION |
|------|-----|--|------|-----|---------------------------------|
| 1 | 1 | Mounting Base | 43 | 1 | Oil Fill & Drain Tube |
| 2 | 1 | Ground Cable | 44 | 1 | Oil Cap & Dipstick |
| 3 | 4 | Rubber Mount | 45 | 1 | Oil Cap O-Ring |
| 4 | 8 | 3/8"-16 x 1/2" Capscrew | 46 | 1 | Oil Drain O-Ring |
| 5 | 10 | M10 Lockwasher | 47 | 1 | Oil Drain Adapter Pipe |
| 6 | 2 | M8 Lockwasher | 56 | 1 | Oil Filter Support |
| 7 | 2 | Rubber Mount Skid | 57 | 1 | Oil Filter (FRAM #PH3814) |
| 8 | 2 | 5/16"-18 x 3.5" Safety Bolt | 58 | 1 | Low Oil Pressure Switch |
| 9 | 2 | 5/16"-18 Hex Nut | 59 | 3 | 5/16" Fitting |
| 10 | 6 | M8-1.25 Flanged Lock Nut | 60 | 1 | Outer Oil Tube |
| 11 | 2 | M8-1.25 x 60mm Capscrew | 61 | 1 | Inner Oil Tube |
| 12 | 2 | Belt Tensioner Spring | 62 | 1 | Oil Pad Adapter |
| 13 | 2 | Spring Centering Washer | 63 | 3 | M6-1.00 x 30mm Capscrew |
| 14 | 4 | Nylon Silde | 64 | 1 | Barbed 90° Fitting |
| 15 | 2 | Nylon Silde Support | 65 | 1 | Oil Pad Gasket |
| 16 | 1 | Exhaust Manifold | 66 | 1 | Grounding Lug |
| 17 | 2 | Exhaust Manifold Gasket | 67 | — | Foam Tape |
| 18 | 4 | M8-1.25 x 20mm Capscrew (Grade 5) | 69 | 1 | High Oil Temperature Switch |
| 19 | 2 | Collector Pan Gasket | 70 | 2 | M3-0.50 Pan Head Screw |
| 20 | 1 | External Cover Plate | 71 | 2 | M3 Lockwasher |
| 21 | 1 | Engine Pulley | 73 | 4 | Spring Retainer Washer |
| 22 | 1 | Generator Pulley | 74 | 1 | Vinyl Cap |
| 23 | 1 | Drive Belt | 75 | 1 | Vinyl Cap |
| 24 | 1 | Pulley Retainer Washer | 76 | 1 | Exhaust Elbow |
| 25 | 1 | 3/8"-24 x 1" Socket Head Capscrew (Grade 5) | 77 | 1 | Fuel Pump Bracket |
| 26 | 1 | Blower Housing Guide | 78 | 1 | Cover |
| 27 | 1 | 3/8"-24 x 2-1/2" Capscrew | 79 | 14 | No. 10-24 Screw |
| 28 | 5 | M6-1.00 x 20mm Screw | 80 | 1 | Slide Pan Gasket |
| 29 | 1 | Fuel Pump Bracket | 81 | 1 | Slide Pan |
| 30 | 1 | Blower Housing | 82 | 8 | M6-1.00 Capscrew (w/Lockwasher) |
| 31 | 1 | Blower Housing Spacer | 83 | 4 | M6 Flatwasher |
| 32 | 6 | M6 Lockwasher | 85 | 1 | Exhaust Outlet Cover |
| 33 | 1 | M6-0.30 Capscrew | 87 | 2 | Exhaust Outlet Gasket |
| 34 | 4 | Generator Mounting Spring | 88 | 1 | Sound Barrier Pad |
| 35 | 2 | M6-1.00 Hex Nut | 90 | 2 | M6 Toothed Lockwasher |
| 36 | 2 | M6-1.00 x 25mm Capscrew | 91 | 1 | Vinyl Coated Clamp |
| 37 | 1 | Fuel Pump | 92 | 9 | M5-0.80 x 10mm Screw |
| 38 | 1 | Fuel Filter | 93 | 2 | 5/16"-18 Flanged Nut |
| 39 | 1 | Fitting (1/8" Pipe to 1/4" Tube) | 94 | 6 | M5 Flatwasher |
| 40 | 1 | Fuel Line | 95 | 1 | Ground Decal |
| 41 | 1 | Grounding Wire | 96 | 9 | M6 x 10mm Screw |
| 42 | 1 | 3/8" NPT Oil Drain | 97 | 1 | M10 Flatwasher |

Chapter Eight- ASSEMBLY (V-TWIN ENGINE UNITS)

Chapter Nine- ASSEMBLY (1-CYLINDER ENGINE UNITS)

General

The vertical shaft, single cylinder engine and the vertically mounted AC generator are mounted side-by-side to the unit's mounting base. The engine power takeoff (PTO) shaft and the generator Rotor shaft extend downward through openings in the mounting base. An engine pulley is attached to the engine PTO shaft; a generator pulley is attached to the Rotor shaft. A drive belt drives the two pulleys and allows the engine to drive the Rotor at its pre-determined speed.

Generator models covered in this Manual are equipped with a 2-pole Rotor. A 2-pole Rotor must be driven at 3600 rpm for a 60 Hertz AC output; or 3000 rpm for a 50 Hertz output. The engine rpm required to drive the Rotor at its proper speed is listed in the CHART on Page 1 of this Manual.

Sheet Metal

Figure 9-2 shows the engine sheet metal and some other engine accessories. A FLYWHEEL (Item 4) includes a cooling air fan and a starter ring gear. The FLYWHEEL is enclosed by a FLYWHEEL SCROLL (Item 1), an ENGINE TOP COVER (Item 7) and an AIR INLET COVER (Item 9). Openings in the AIR INLET COVER allow air to be drawn in by the cooling air fan. The FLYWHEEL (Item 4) is retained to the engine shaft by a M20-1.50 NUT (Item 6) and a BELLEVILLE WASHER (Item 5).

Air Cleaner, Carburetor and Choke

See Figure 9-3. The CARBURETOR (Item 6) and AIR CLEANER BASE (Item 6) are retained to the engine INTAKE MANIFOLD (Item 1). Governor, throttle and choke linkages are also shown in Figure 9-3.

AC Generator

The generator proper consists of the following major parts, shown in Figure 9-4:

- Generator Top Housing (Item 12).
- Brush Holder with Brushes (Item 9).
- Upper Bearing Carrier (Item 6).
- Stator Assembly (Item 3).
- Lower Bearing Carrier (Item 1).
- Rotor Assembly (Item 2).

The Stator Assembly is sandwiched between the upper and lower bearing carriers and retained by four Stator Studs (Item 7). The units is a "2-bearing" type with the Rotor supported in two ball bearings (Items 4 and 5).

Control Panel

Control Panel components are shown in Figure 9-4. The following parts are housed in the Control Panel:

- Engine Controller Circuit Board (Item 20).
- Starter Contactor (Item 29).
- Battery Charge Rectifier (Item 32).
- Excitation Circuit Breaker (Item 41).
- AC Voltage Regulator (Item 43).
- Main Circuit Breakers (Items 46 and 47).
- 15 amp Fuse Holder with Fuse (Item 52, 53).
- Start-Stop Switch (Item 54).
- Fuel Primer Switch (Item 55).

Mounting Base and Pulleys

Figure 9-5 shows the engine-generator MOUNTING BASE (Item 1). The engine-generator PULLEYS (Items 21 and 22) include blowers which operate in a BLOWER HOUSING (Item 30) to move air and fumes downward and away from the unit. A SLIDE PAN (Item 50) provides needed air and exhaust openings and acts as a "floor" for the unit.

Drive belt tension is adjusted by means of two (2) BELT TENSIONING SPRINGS (Item 12), CAPSCREWS (Item 11), SPRING WASHERS (Item 13) and FLANGED LOCK NUTS (Item 10). Turning the two CAPSCREWS (Item 11) moves the generator's lower bearing carrier axially on NYLON SLIDES (Item 14) and changes the tension on the DRIVE BELT (Item 23).

The generator's lower bearing carrier is retained to the mounting base by four (4) SPRINGS (Item 34).

See Figure 9-1, below. To adjust belt tension, turn the two adjusting bolts until the compressed length of the two springs is 5/8 inch (16mm).

To adjust the tension of the four lower bearing carrier springs, turn the adjusting bolts to obtain a compressed spring length of 7/8 inch (22mm).

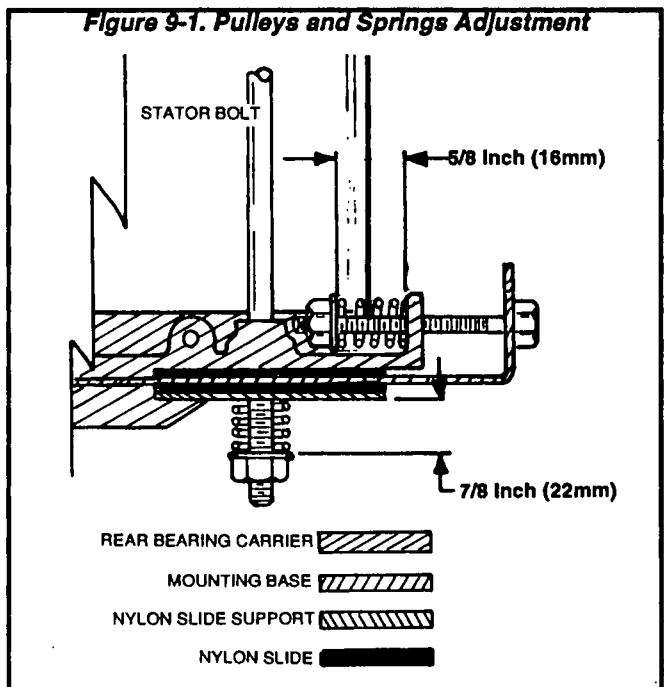

Chapter Nine- ASSEMBLY (1-CYLINDER ENGINE UNITS)

Figure 9-2. Sheet Metal & Engine Accessories (Drawing No. 94108)

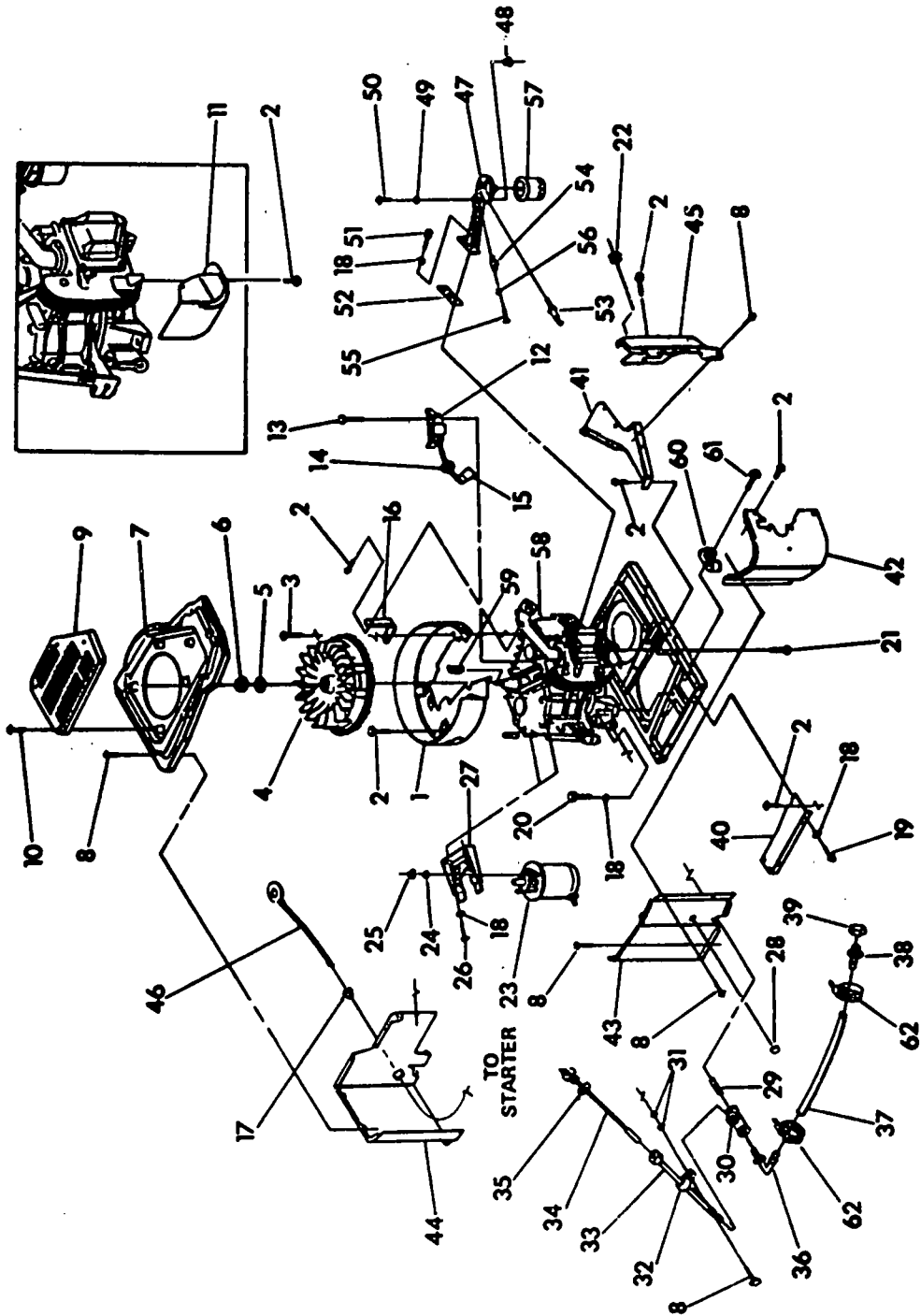

Chapter Nine- ASSEMBLY (1-CYLINDER ENGINE UNITS)

Parts List for Figure 9-2 (Drawing No. 94108)

| ITEM | QTY | DESCRIPTION | ITEM | QTY | DESCRIPTION |
|------|-----|---------------------------------|------|-----|-----------------------------|
| 1 | 1 | Flywheel Scroll | 32 | 1 | Vinyl Coated Clamp |
| 2 | 7 | M6-1.00 x 10mm Screw | 33 | 1 | Dipstick Tube |
| 3 | 1 | M6-1.00 x 12mm Screw | 34 | 1 | Oil Cap and Dipstick |
| 4 | 1 | Flywheel | 35 | 1 | O-Ring |
| 5 | 1 | M20 Belleville Washer | 36 | 1 | 3/8" Elbow |
| 6 | 1 | M20-1.50 Nut | 37 | 1 | 3/8" NPT Hose |
| 7 | 1 | Engine Top Cover | 38 | 1 | Barbed Fitting |
| 8 | 20 | No. 10-24 x 1/2" Screw | 39 | 1 | 1/4" NPT Cap |
| 9 | 1 | Air Inlet Cover | 40 | 1 | Starter Side Cover |
| 10 | 5 | No. 8 x 1/4" Screw | 41 | 1 | Carburetor Side Cover |
| 11 | 1 | Exhaust Port Deflector | 42 | 1 | Engine Spark Plug Wrapper |
| 12 | 1 | Ignition Coil | 43 | 1 | Starter Side Wrapper |
| 13 | 2 | M6-1.00 x 25mm Screw | 44 | 1 | Rear Gear Case Wrapper |
| 14 | 1 | Rubber Grommet | 45 | 1 | Carburetor Side Wrapper |
| 15 | 1 | Spark Plug Boot | 46 | 1 | Starter Cable |
| 16 | 1 | Intake Manifold Support Bracket | 47 | 1 | Oil Filter Support |
| 17 | 1 | Rubber Grommet | 48 | 1 | Rubber Bushing |
| 18 | 8 | Lockwasher | 49 | 1 | Rubber Washer |
| 19 | 2 | M8-1.25 x 15mm Capscrew | 50 | 1 | M6 x 15mm Shoulder Bolt |
| 20 | 2 | M8-1.25 x 40mm Capscrew | 51 | 2 | M8-1.25 x 30mm Socket |
| 21 | 2 | 3/8"-16 x 3/4" Screw | | | Head Capscrew |
| 22 | 1 | Rubber Grommet | 52 | 1 | Oil Filter Support Gasket |
| 23 | 1 | Starter Motor | 53 | 1 | Low Oil Pressure Switch |
| 24 | 2 | 1/4" Lockwasher | 54 | 1 | High Oil Temperature Switch |
| 25 | 2 | 1/4"-20 Hex Nut | 55 | 2 | M3-0.50 x 5mm Screw |
| 26 | 2 | M8-1.25 x 20mm Capscrew | 56 | 2 | M3 Lockwasher |
| 27 | 1 | Starter Mounting Bracket | 57 | 1 | Oil Filter |
| 28 | 1 | Plug Button | 58 | 1 | GN360 Engine |
| 29 | 1 | 3/8" NPT Nipple | 59 | 1 | Woodruff Key |
| 30 | 1 | 3/8" NPT Pipe Tee | 60 | 1 | Hose Retainer Clip |
| 31 | 2 | Flatwasher | 61 | 1 | M5-0.80 x 10mm Screw |
| | | | 62 | 2 | Hose Clamp |

Chapter Nine- ASSEMBLY (1-CYLINDER ENGINE UNITS)

Figure 9-3. Exploded View of Air Cleaner, Carburetor and Choke (Drawing No. 92200)

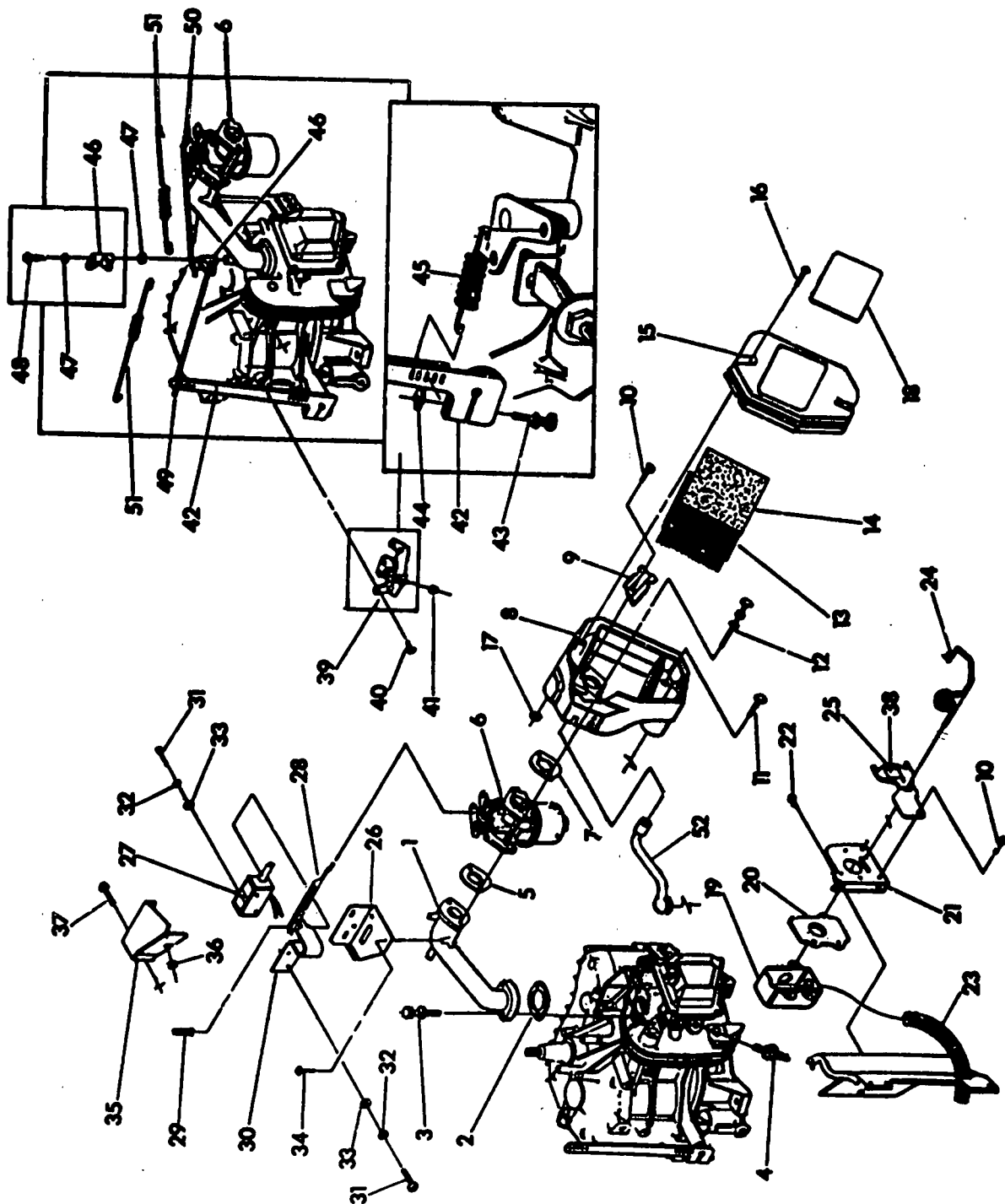

Chapter Nine- ASSEMBLY (1-CYLINDER ENGINE UNITS)

Parts List for Figure 9-3 (Drawing No. 92200)

| ITEM | QTY | DESCRIPTION | ITEM | QTY | DESCRIPTION |
|------|-----|-----------------------------------|------|-----|-----------------------------------|
| 1 | 1 | Intake Manifold | 27 | 1 | Choke Solenoid |
| 2 | 1 | Manifold Head Gasket | 28 | 1 | Choke Linkage |
| 3 | 2 | M6-1.00 x 20mm Capscrew | 29 | 1 | Cotter Pin |
| 4 | 1 | Spark Plug (Champion RC12YC) | 30 | 1 | Choke Heater Assembly |
| 5 | 1 | Carburetor-Manifold Gasket | 31 | 4 | No. 4-40 Screw |
| 6 | 1 | Carburetor | 32 | 4 | No. 4 Lockwasher |
| 7 | 1 | Carburetor-Air Cleaner Gasket | 33 | 4 | No. 4 Flatwasher |
| 8 | 1 | Air Cleaner Base | 34 | 2 | M5 x 10mm Screw |
| 9 | 1 | Carburetor Shield | 35 | 1 | Choke Cover |
| 10 | 4 | No. 8 x 3/8" Screw (Plastite) | 36 | 1 | Rubber Grommet |
| 11 | 1 | M6 x 12mm Capscrew (w/Lockwasher) | 37 | 1 | No. 8 x 3/8" Screw |
| 12 | 2 | Carburetor Mounting Bolt | 38 | 1 | Summer/Winter Decal |
| 13 | 1 | Air Cleaner | 39 | 1 | Governor Spring Adjust Bracket |
| 14 | 1 | Air Cleaner Pre-Filter | 40 | 2 | M8 x 15mm Screw |
| 15 | 1 | Air Cleaner Cover | 41 | 1 | M5-0.80 Lock Nut |
| 16 | 2 | Air Cleaner Cover Bolt | 42 | 1 | Governor Arm Lever |
| 17 | 2 | M6-1.00 Hex Nut | 43 | 1 | M6 x 30mm Capscrew (w/Lockwasher) |
| 18 | 1 | Air Cleaner Data Decal | 44 | 1 | M8 Nut (Special) |
| 19 | 1 | Heat Riser Box | 45 | 1 | Governor Spring |
| 20 | 1 | Heat Riser Box Gasket | 46 | 1 | Governor Rod Bell Crank |
| 21 | 1 | Air Cleaner Support Bracket | 47 | 2 | Felt Washer |
| 22 | 2 | M6-1.00 x 10mm Screw | 48 | 1 | M6 x 15mm Shoulder Bolt |
| 23 | 1 | Heat Riser Tube | 49 | 1 | Governor Lever to Bell Crank Rod |
| 24 | 1 | Winter/Summer Lever | 50 | 1 | Bell Crank to Carburetor Rod |
| 25 | 1 | Summer/Winter Valve Guide Plate | 51 | 2 | Governor Lever-Bell Crank Spring |
| 26 | 1 | Choke Bracket | 52 | 1 | Breather Tube |

Chapter Nine- ASSEMBLY (1-CYLINDER ENGINE UNITS)

Figure 9-4. Exploded View of Generator & Control Panel (Drawing No. 94106)

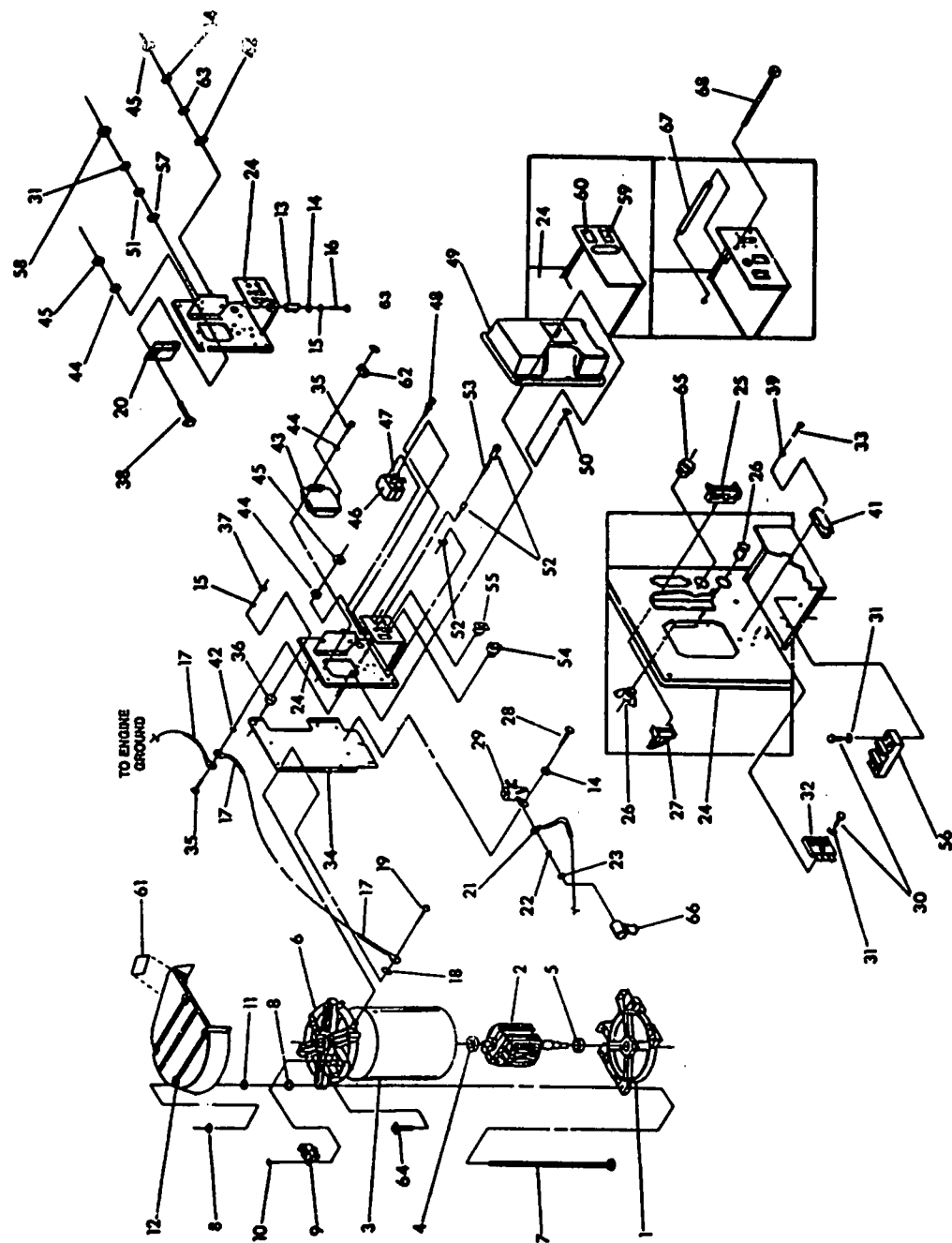

Chapter Nine- ASSEMBLY (1-CYLINDER ENGINE UNITS)

Parts List for Figure 9-4 (Drawing No. 94106)

| ITEM | QTY | DESCRIPTION | ITEM | QTY | DESCRIPTION |
|------|-----|---------------------------------|------|-----|---|
| 1 | 1 | Lower Bearing Carrier | 35 | 3 | M5-0.80 x 30mm Capscrew |
| 2 | 1 | Rotor Assembly | 36 | 4 | Vibration Mount |
| 3 | 1 | Stator Assembly | 37 | 4 | M6-1.00 Hex Nut |
| 4 | 1 | Ball Bearing | 38 | 1 | M5-0.80 x 16mm Capscrew |
| 5 | 1 | Ball Bearing | 39 | 2 | M3 Lockwasher |
| 6 | 1 | Upper Bearing Carrier | 41 | 1 | Excitation Circuit Breaker |
| 7 | 4 | Stator Stud | 42 | 2 | M5 Washer |
| 8 | 8 | M8-1.25 Flanged Lock Nut | 43 | 1 | Voltage Regulator |
| 9 | 1 | Brush Holder | 44 | 6 | M5 Lockwasher |
| 10 | 2 | M5-0.80 x 16mm Screw | 45 | 4 | M5-0.80 Hex Nut |
| 11 | 4 | Nylon Washer | 46 | 1 | Main Circuit Breaker |
| 12 | 1 | Generator Top Housing | 47 | 1 | Main Circuit Breaker |
| 13 | 1 | Resistor | 48 | 4 | No. 6-32 Screw (w/Lockwasher) |
| 14 | 3 | M6 Flatwasher | 49 | 1 | Panel Cover |
| 15 | 5 | M6 Lockwasher | 50 | 4 | M4-0.70 x 16mm Screw (w/Lockwasher & Flatwasher) |
| 16 | 1 | M6-1.00 x 60mm Capscrew | 51 | 1 | M4 Flatwasher |
| 17 | 2 | Ground Wire | 52 | 1 | Fuse Holder |
| 18 | 1 | Lockwasher | 53 | 1 | 15 amp Fuse |
| 19 | 4 | M6-1.00 x 20mm Screw | 54 | 1 | Start-Stop Switch (SPDT) |
| 20 | 1 | Engine Controller Circuit Board | 55 | 1 | Fuel Primer Switch (SPDT) |
| 21 | 1 | Starter Cable | 56 | 1 | Terminal Block |
| 22 | 2 | 5/16" Lockwasher | 57 | 1 | M4 Lockwasher |
| 23 | 2 | 5/16"-18 Hex Nut | 58 | 1 | M4-0.70 Hex Nut |
| 24 | 1 | Panel Sheet Metal | 59 | 1 | Circuit Breaker Rating Decal (30A) |
| 25 | 1 | 4-Tab Connector | 60 | 1 | Circuit Breaker Rating Decal (20A) |
| 26 | 1 | Connector | 61 | 1 | Customer Connection decal |
| 27 | 1 | Remote Harness | 62 | 1 | Hose Clamp |
| 28 | 2 | M6-1.00 x 12mm Capscrew | 63 | 1 | M5 Flatwasher |
| 29 | 1 | Starter Contactor | 64 | 1 | M5 x 10mm Screw |
| 30 | 3 | M4-0.70 x 16mm Capscrew | 65 | 1 | Bushing |
| 31 | 4 | M4 Lockwasher | 66 | 1 | Battery Cable Boot |
| 32 | 1 | Battery Charge Rectifier | 67 | 1 | Plastic Spacer |
| 33 | 2 | M3-0.50 x 15mm Capscrew | 68 | 1 | M6-0.80 x 110mm Pan Head Machine Screw |
| 34 | 1 | Panel Support Bracket | | | |

Chapter Nine- ASSEMBLY (1-CYLINDER ENGINE UNITS)

Figure 9-5. Exploded View of Base & Pulleys (Drawing No. 92197)

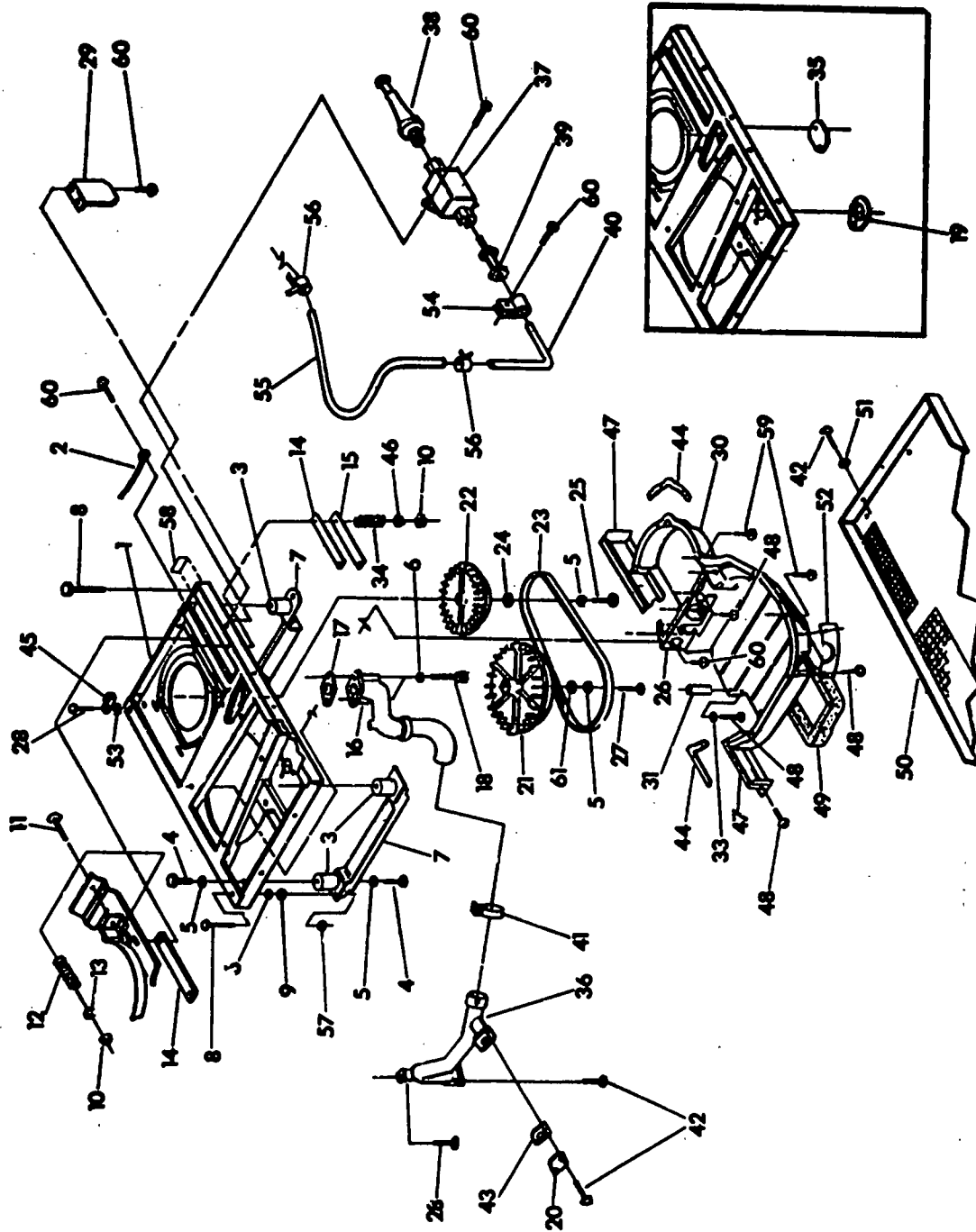

Chapter Nine- ASSEMBLY (1-CYLINDER ENGINE UNITS)

Parts List for Figure 9-5 (Drawing No. 92197)

| ITEM | QTY | DESCRIPTION | ITEM | QTY | DESCRIPTION |
|------|-----|--|------|--------|--|
| 1 | 1 | Mounting Base | 31 | 1 | Blower Housing Spacer |
| 2 | 1 | Ground Cable | 32 | 1 | M6 Lockwasher |
| 3 | 4 | Rubber Mount | 33 | 1 | M5-0.80 x 80mm Capscrew |
| 4 | 8 | 3/8"-16 x 1/2" Capscrew | 34 | 4 | Generator Set Mounting Spring |
| 5 | 10 | M10 Lockwasher | 35 | 1 | Exhaust Cover Plate |
| 6 | 4 | M8 Lockwasher | 36 | 1 | Universal Exhaust Adapter |
| 7 | 2 | Rubber Mount Skid | 37 | 1 | Fuel Pump |
| 8 | 2 | 5/16"-18 x 3-1/2" Safety Bolt | 38 | 1 | Fuel Filter |
| 9 | 2 | 5/16"-18 Hex Nut | 39 | 1 | Fitting (1/8" Pipe to 1/4" Tube) |
| 10 | 6 | M8-1.25 Flanged Lock Nut | 40 | 1 | Fuel Tube |
| 11 | 2 | M8-1.25 x 60mm Capscrew | 41 | 1 | Exhaust Pipe Clamp |
| 12 | 2 | Belt Tensioning Spring | 42 | 8 | M6-1.00 x 16mm Capscrew (Includes Lockwasher) |
| 13 | 2 | Spring Centering Washer | 43 | 1 | Exhaust Pipe Gasket |
| 14 | 4 | Nylon Slide | 44 | 10 ft. | Foam Tape |
| 15 | 2 | Nylon Slide Support | 45 | 1 | Grounding Lug |
| 16 | 1 | Exhaust Manifold | 46 | 4 | Spring Retainer Washer |
| 17 | 1 | Exhaust Manifold Gasket | 47 | 1 | Air Opening Cover |
| 18 | 2 | M8-1.25 x 65mm Socket Head Capscrew | 48 | 11 | No. 10-24 x 1/2" Screw |
| 19 | 1 | Collector Pan Gasket | 49 | 1 | Slide Pan Foam Gasket |
| 20 | 1 | External Cover Plate | 50 | 1 | Slide Pan |
| 21 | 1 | Engine Pulley | 51 | 4 | M8 Flatwasher |
| 22 | 1 | Generator Pulley | 52 | 1 | Exhaust Outlet Cover |
| 23 | 1 | Drive Belt | 53 | 2 | M6 Lockwasher |
| 24 | 1 | Pulley Retainer Washer | 54 | 2 | Vinyl Coated Clamp |
| 25 | 1 | 3/8"-24 x 2-1/2" Socket Head Capscrew | 55 | 1 | Fuel Hose |
| 26 | 1 | Blower Housing Guide | 56 | 2 | Hose Clamp |
| 27 | 1 | 3/8"-24 x 2-1/2" Capscrew | 57 | 2 | 5/16"-18 Flanged Nut |
| 28 | 2 | M6-1.00 x 20mm Screw | 58 | 1 | Grounding Decal |
| 29 | 1 | Fuel Pump Bracket | 59 | 9 | M5-0.80 x 10mm Screw |
| 30 | 1 | Fitting (1/8" Pipe to 1/4" Tube) | 60 | 6 | M6-1.00 x 10mm Screw |
| | | | 61 | 1 | M10 Flatwasher |

Chapter Nine- ASSEMBLY (1-CYLINDER ENGINE UNITS)

Chapter Ten- ELECTRICAL DATA

Nominal Resistance of Rotor and Stator Windings In OHMS at 68° F. (20° C.)

| UNIT RATED WATTS | 5000 | 5200 | 5500 | 6600 | 7000 | 7200 |
|---|------|------|------|-------|------|------|
| STATOR EXCITATION (DPE) WINDINGS (Wires 2 and 6) | 1.43 | 1.43 | 1.43 | 1.60 | 1.55 | 1.55 |
| STATOR POWER WINDINGS Wires 11P to 22P Wires 33 to 44 | 0.29 | 0.29 | 0.29 | 0.23 | 0.21 | 0.21 |
| STATOR BATTERY CHARGE WINDINGS Wires 55 to 66 Wires 55 to 77 | 0.09 | 0.09 | 0.09 | 0.07 | 0.07 | 0.07 |
| ROTOR WINDINGS Across the Slip Rings | 15.5 | 15.5 | 15.5 | 10.81 | 11.3 | 11.3 |

Electrical Formulas

| DESIRED DATA | 1-PHASE | 3-PHASE |
|--|--|--|
| KILOWATTS (Generator output or Load Input) | $\frac{\text{Volts} \times \text{Amps} \times \text{P. F.}}{1000}$ | $\frac{1.73 \times \text{Volts} \times \text{Amps} \times \text{P. F.}}{1000}$ |
| KVA (Generator output or Load Input) | $\frac{\text{Volts} \times \text{Amps}}{1000}$ | $\frac{1.73 \times \text{Volts} \times \text{Amps}}{1000}$ |
| HORSEPOWER (Engine Output) | $\frac{\text{Volts} \times \text{Amps} \times 100 \times \text{P. F.}}{746 \times \text{Efficiency}}$ | $\frac{1.73 \times \text{Volts} \times \text{Amps} \times 100 \times \text{P. F.}}{746 \times \text{Efficiency}}$ |
| AMPERES (When Horsepower is known) | $\frac{\text{H. P.} \times 746 \times \text{Efficiency}}{\text{Volts} \times 100 \times \text{P. F.}}$ | $\frac{\text{H. P.} \times 746 \times \text{Efficiency}}{1.73 \times \text{Volts} \times 100 \times \text{P. F.}}$ |
| AMPERES (When Kilowatts are known) | $\frac{\text{Kilowatts} \times 1000}{\text{Volts} \times \text{P. F.}}$ | $\frac{\text{Kilowatts} \times 1000}{1.73 \times \text{Volts} \times \text{P. F.}}$ |
| AMPERES (When KVA is known) | $\frac{\text{kVA} \times 1000}{\text{Volts}}$ | $\frac{\text{kVA} \times 1000}{1.73 \times \text{Volts}}$ |
| FREQUENCY | $\frac{\text{RPM} \times \text{No. of Rotor Poles}}{2 \times 60}$ | $\frac{\text{RPM} \times \text{No. of Rotor Poles}}{2 \times 60}$ |
| NO. OF ROTOR POLES | $\frac{2 \times 60 \times \text{Frequency}}{\text{RPM}}$ | $\frac{2 \times 60 \times \text{Frequency}}{\text{RPM}}$ |
| RPM | $\frac{2 \times 60 \times \text{Frequency}}{\text{No. of Rotor Poles}}$ | $\frac{2 \times 60 \times \text{Frequency}}{\text{No. of Rotor Poles}}$ |

1. Efficiency in the above formulas is expressed in percent, such as "95%".

2. P. F. is "Power Factor" and is generally 1.0 (Unity) for 1-phase units; 0.8 for 3-phase units.

3. "Volts" refers to line-to-line measurement.

Chapter Ten- ELECTRICAL DATA

Figure 10-1. Electrical Schematic (Drawing No. 89405)
For Generator Models 9202-1, 9203-1, 9204-1, 9205-1, 9206-1, 9207-1

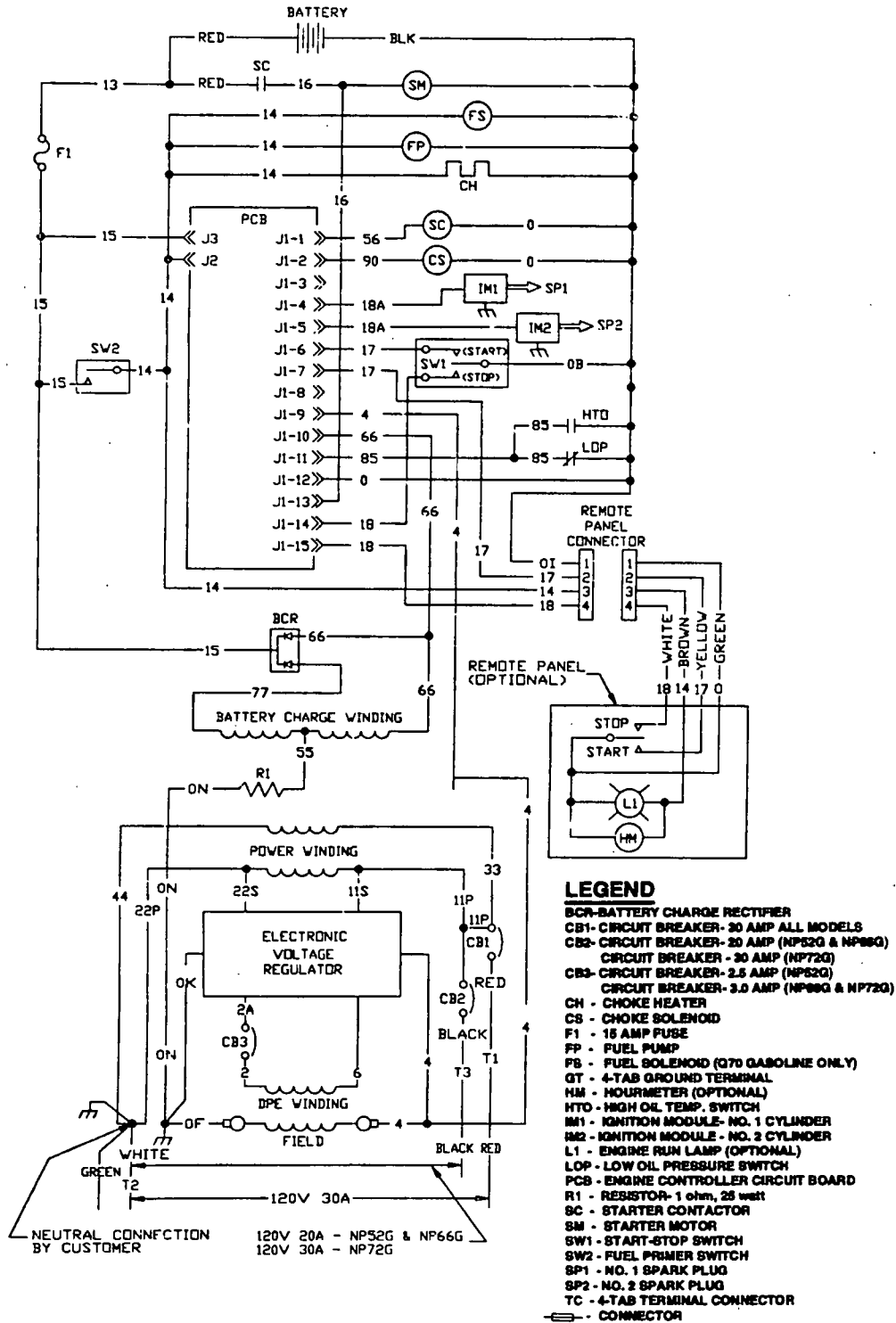

Chapter Ten- ELECTRICAL DATA

Figure 10-3. Electrical Schematic (Drawing No. 93924)
For Generator Model No. 9290-2

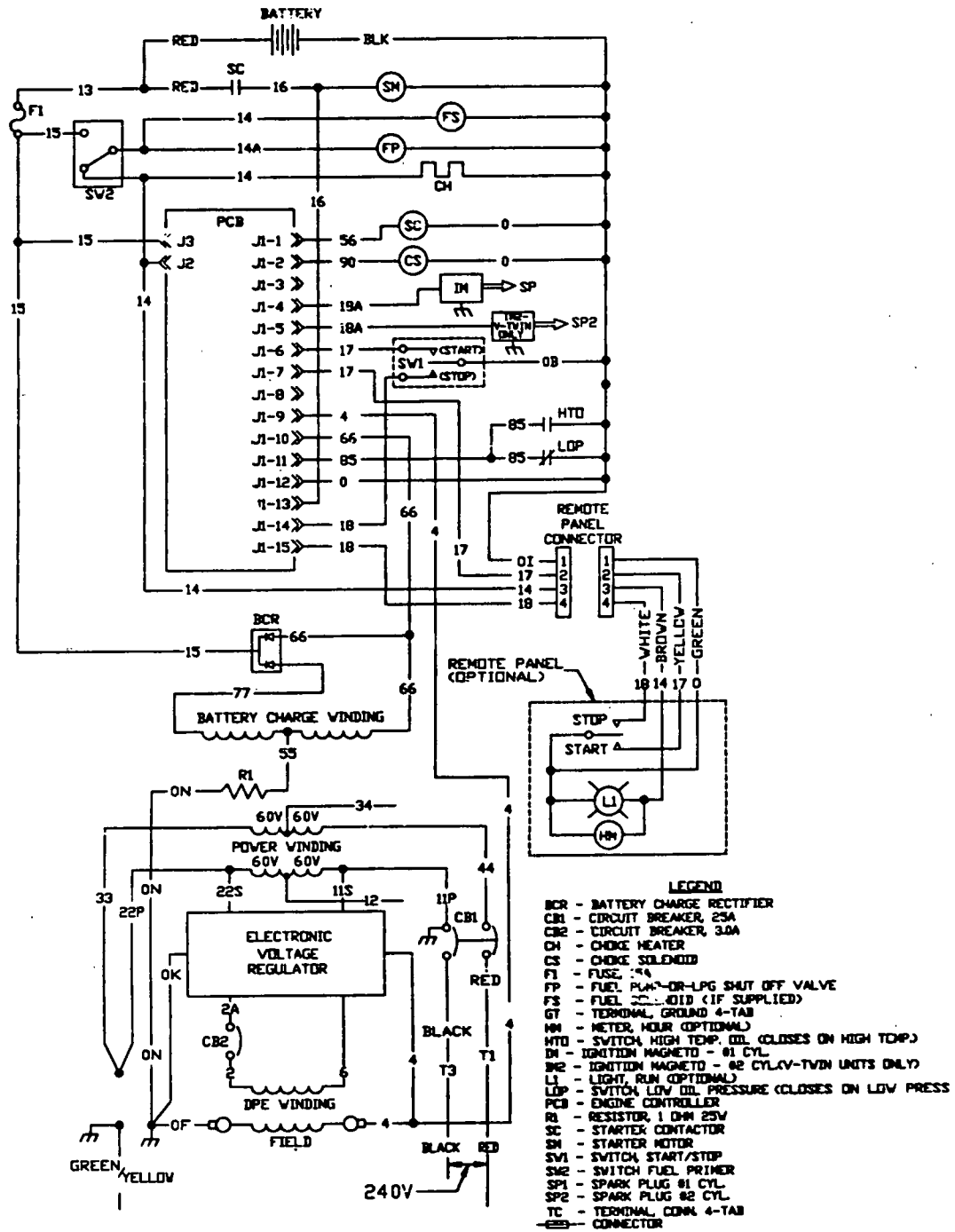

Chapter Ten- ELECTRICAL DATA

**Figure 10-5. Electrical Schematic (Drawing No. 90206)
For Generator Model No. 9509-2**

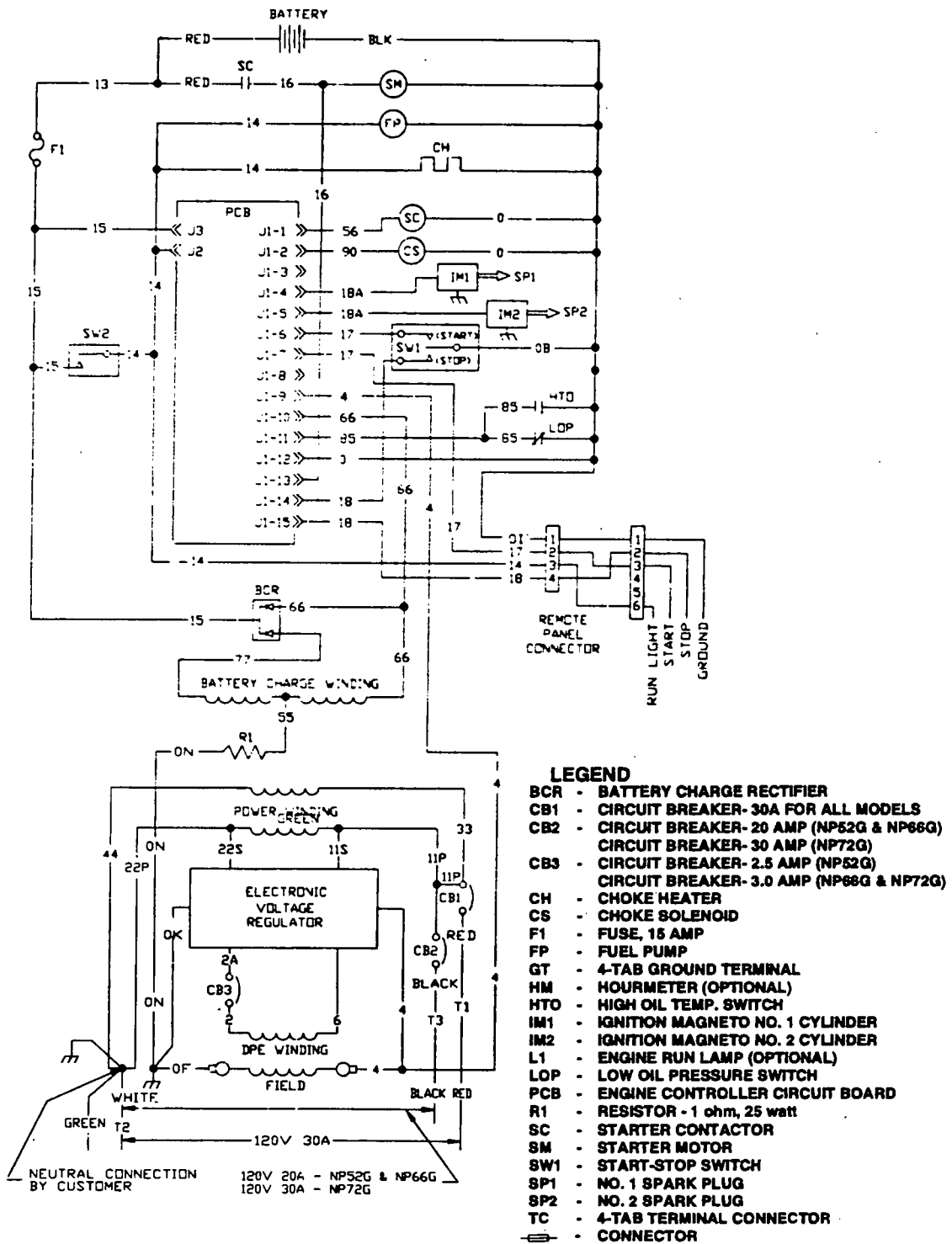

Chapter Ten- ELECTRICAL DATA

Figure 10-7. Electrical Schematic (Drawing No. 92116)

For Generator Models 9592-1, 9592-2, 9593-0, 9593-1, 9593-2, 9600-0, 9600-1, 9600-2, 9677-1, 9677-2, 9677-3, 9677-4, 9712-0, 9712-1, 9734-1, 9735-1, 9736-1

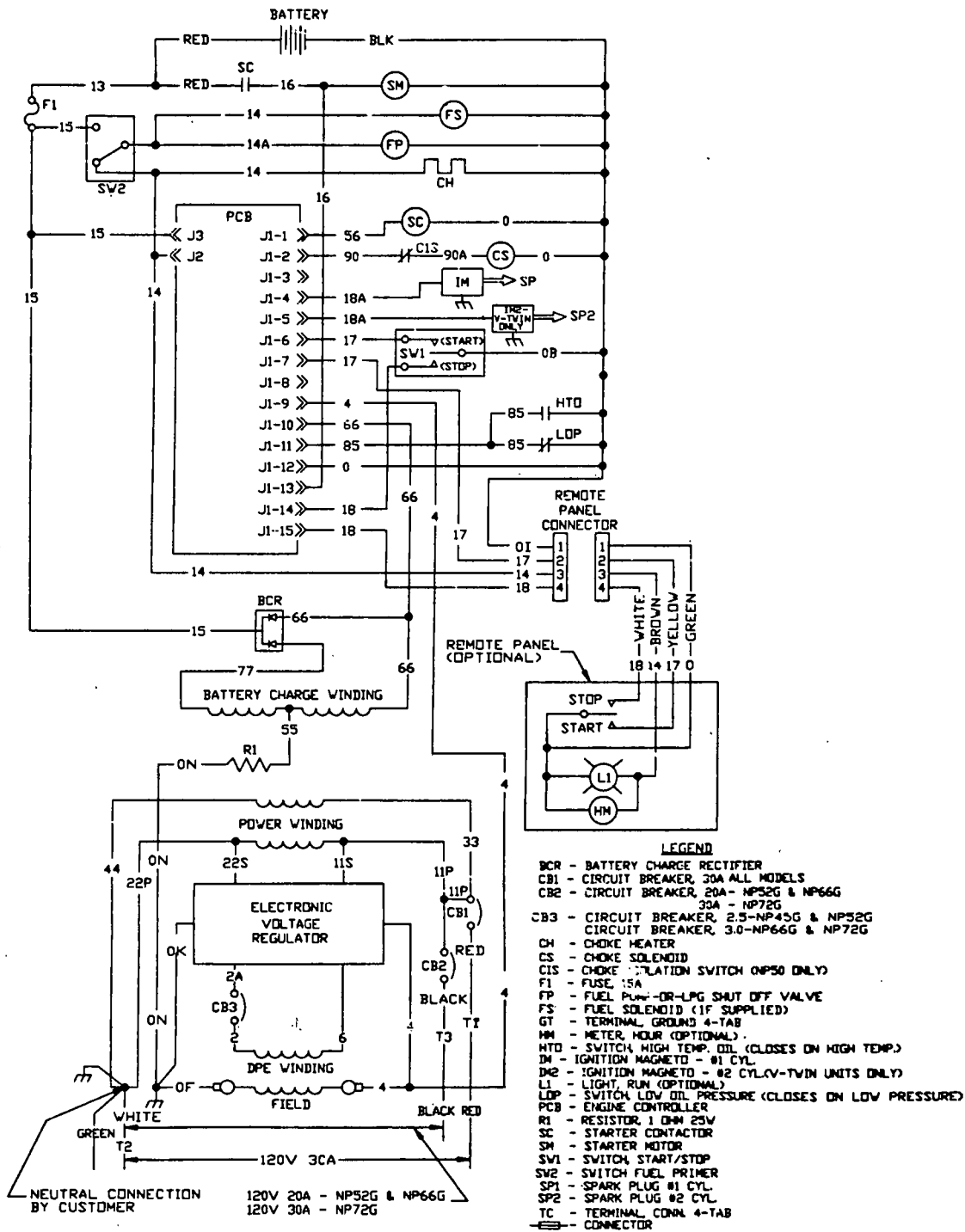

Chapter Ten- ELECTRICAL DATA

Figure 10-8. Wiring Diagram (Drawing No. 92116)
For Generator Models same as Figure 10-7

