

DYNATRAIL

INSTALLATION, OPERATING, AND SERVICE INSTRUCTIONS

For Model

P-45M

45,000 BTU Gas Furnace
115 Volt AC

FOR YOUR SAFETY

If you smell gas:

1 -Open all windows.

2-Don't touch any electrical switches.

3-Extinguish open flames.

4-Immediately call your gas supplier.

This book contains instructions for installation and operation of your furnace. Keep with unit at all times.

Should you require further information, contact your dealer or Suburban Service Center.

FOR YOUR SAFETY

Do not store or use gasoline or other flammable vapor* and liquids in the vicinity of this or any other appliance.

SUBURBAN
MANUFACTURING COMPANY

Form No. 2022-C
9-81

SUBURBAN MANUFACTURING COMPANY P.O. BOX 399 e DAYTON, TENNESSEE 37321

***** Important *****

Read the following before installing furnace!

- 1-Do not install furnace unless the tubes on the vent caps overlap the exhaust tubes on the furnace at least 1 1/2".
- 2-Do not omit or substitute the special 3" screw on exterior vent assemblies. This anchors the furnace to the vent assemblies and outer skin of the coach. (See Figure 2.)
- 3-Do not use any compound on threaded joints that is not resistant to liquid petroleum gas.
- 4-Do not make any pipe connection without afterwards checking for leakage use soap and water solution.
- 5-Do not use open flame to check for leaks.
- 6-Do not install the furnace with floor coverings under the cabinet.
- 7-Do not use unauthorized gauge wire. 14-gauge wire is required.
- 8-Do not replace any wiring on the furnace with anything less than type 105C wire or its equivalent.
- 9-Do not install furnace without adequate return air (85 square inches, minimum).
- 10-Do not install furnace unless in compliance with local codes. (See *Installation Instructions*.)
- 11 -Do not install unless clearances from combustible materials are adhered to. (See *Installation Instructions*.)
- 12-Do not attempt to ignite a direct ignition furnace with a match, butane torch, or flint type igniters. (Follow *Lighting Instructions*.)
- 13-Do not operate (lie furnace with electrode wire or the electrode assembly disconnected.
- 14-Do not use a screwdriver or metal object on any portion of the electrode assembly furnace is in operation - damage to module board could occur.
- 15-Do not operate the furnace if the spark from the electrode is jumping to the flame portion of the electrode assembly. (See Figure 8 for proper gapping of the electrode assembly)
- 16-Do not attempt field repairs to the module board - if found to be defective, replace it.
- 17-Do not make design changes or modify the operation of the furnace in any way.
- 18-Do not install furnace where it cannot be easily removed for service.
- 19-Do not attempt repairs yourself. All repairs should be made by a qualified service agency.

Thank you for reading this far - please read entire manual before installing furnace.

Introduction

The furnace in your recreational vehicle is a direct vent system furnace design certified by the American Gas Association for safety and performance. It is for installation in recreational vehicles only.

The model number of your furnace is as follows:

P-45M

115 Volts AC; 45,000 BTU/HR Input

The furnace utilizes a direct vent system with a compound blower to circulate room air around the sealed combustion chamber as well its furnish outside air to the burner to support combustion. The combustion air blower then forces the flue products to the outside atmosphere for maximum safety and heating efficiency.

Installation Instructions

! WARNING! This furnace is not designed for, nor is it to be used in conjunction with, cooling units. To do so will damage furnace and void the warranty.

The furnace is design certified for use with natural gas or liquefied petroleum (L.P) gas.

The furnace is designed to operate at the following gas inlet supply pressure:

	Minimum	Maximum
Natural Gas	5" W.C.	7" W.C.
Liquefied Petroleum (LP) Gas	11" W.C.	14" W.C.

In the USA, the installation of the furnace must be in accordance with local codes and regulations. In the absence of local codes and regulations refer to:

1 -American National *Standard for Recreational Vehicles A119.21* NFPA 501C-1975.

2-National *Fuel Code ANSI Z233.1-1974.*

3-Furnace must be electrically grounded in accordance with the National *Electrical Code ANSI CF1978.*

INSTALLATION

There are three methods described below for installing the furnace. Regardless of the method you choose, Suburban requires that a permanent opening be provided in the interior cabinetry of the coach directly in front of the furnace. The opening must allow for free, unobstructed removal of the furnace. This opening is also used as a means of providing circulating return air to the furnace. It is important that adequate return air be provided to assure normal heating and operation of the furnace. Failure to provide the

minimum return air opening (85 square inches), as well as an adequate opening for removal of the furnace, voids the warranty.

A-Installation Directly Against Outer Skin Of Coach (See Figure 1)

!WARNING! Maximum wall thickness for this type of installation 2 ½”.

1-Locate furnace near lengthwise center of the coach.

2-Choose a location for installation out of the way of wires, pipes, etc. that might interfere with the installation. Also, adhere to the following minimum clearances from the furnace cabinet to combustible construction:

Right Side 2"	Top 14"	Bottom 0"
Left Side 2"	Front 12"	Back 0"

3-Cut an opening through the inner wall 24 3/16" wide x 14 3/16" high. Do *not cut through outer skin!* This will allow the rear of the furnace to be installed against the outer skin of the coach. *NOTE: Whenever the furnace cabinet is installed through the wall, the return air louvers on the furnace cabinet must not be blocked.* Figure 1 illustrates the maximum projection of the furnace cabinet into the wall as 2 ½”.

4-Carpet and floor coverings must be removed from under the furnace when the installation is such that the weight of the furnace rests on the floor covering. If the furnace is allowed to rest on the floor covering, it may settle into the material, thus reducing our clearances under the furnace. It will not be necessary to remove the floor covering if the furnace is not mounted directly on the material.

5-Center furnace cabinet in opening and locate the center lines of the exhaust and intake tubes as shown in Figure 2,

6-Cut three (3) 2 1/4" diameter holes through outer skin of coach as shown.

7-Put furnace in place making sure that rear of furnace cabinet is firmly against outer skin of coach.

8-Fasten furnace to floor of coach using the two holes provided in the front plenum area of furnace cabinet.

9-Install vent assembly - see instructions for installing vent.

10-Secure cabinet front to furnace cabinet using 4 screws provided.

B-Installation Directly Against Inner Wall of Coach (See Figure 3)

!WARNING! Maximum wall thickness for this type installation is 2”

1-Locate furnace near lengthwise center of coach,

2-Choose a location for installation out of the way of wires, pipes, etc. that might interfere with the installation. Also, adhere to the following minimum clearances from the furnace cabinet to combustible construction:

Right Side	2"	Top	- 1/4"	Exhaust and
Left Side	2"	Front	1/2"	Intake Tubes- 7/8"
		Back	0"	Bottom - 0"

3-Carpet and floor coverings must be removed from under the furnace when the installation is such that the weight of the furnace rests on the floor covering. If the furnace is allowed to rest on the floor covering, it may settle into the material, thus reducing our clearances under the furnace. It will not be necessary to remove the floor covering if the furnace is not mounted directly on the material.

4-Locate the centerlines of the exhaust and intake tubes as shown in Figure 2.

5-Cut three (3) 4" diameter holes through inner wall. **Do not cut through outer skin.**

6-Cut three (3) 2 1/4" diameter holes through outer skin as shown.

7-Put furnace in place, making sure that rear of furnace cabinet is firmly against inner wall of coach.

8-Fasten furnace to floor of coach using the two holes provided in front plenum area of furnace cabinet.

9-Install vent assembly - see **Instructions for Installing Vent.**

10-Secure cabinet front to furnace cabinet using the 4 screws provided.

C-Installation Using Vent Extension Tubes (See Figure 4)

When it is not possible to install the furnace as described in installations A or B, extension tubes must be used to extend the exhaust and intake tubes on the furnace to the vent tube assemblies on the outside of the coach.

Avoid the use of extension tubes whenever possible. If they must be used, installation must be made as follows:

1-Locate center lines for exhaust and intake tubes as shown in Figure 2.

2-Cut three (3) 4"diameter holes for exhaust and intake tubes through inner wall. **Do not cut through outer skin.** (See Figure 3.)

3-Cut three (3) 2 1/4" diameter holes through outer skin. (See Figure 4.)

4-Carpet and floor coverings must be removed from under the furnace when the installation is such that the weight of the furnace rests on the floor covering. If the furnace is allowed to rest on the floor covering, it may settle into the material, thus reducing our clearances under the furnace. It will not be necessary to remove the floor covering if the furnace is not mounted directly on the material.

5-Determine what length extension tube is required for the exhaust and intake tubes by positioning the furnace in its permanent location and measuring the distance from the end of the exhaust and intake tubes to the outer edge of the coach skin. Add ½" to the measured distance. This gives the minimum length extension tubes you must order. Only Suburban extension tubes are to be used.

WARNING – Under no circumstances are the air the extension tubes, as supplied by Suburban, to be cut, altered or modified in any way. To do so could be dangerous and will void the responsibility of Suburban.

6-Secure furnace back to cabinet. Cabinet back and screws will be included with extension tubes.

7-Attach each extension tube to cabinet back as shown.

8-Put furnace in place, making sure that the extension tubes terminate flush with the outer skin, or no less than ¾" from the outer skin of the coach, and that they are tightly fitted on the exhaust and intake tubes on the furnace.

9-Fasten furnace to the coach flooring using the two holes provided in the front plenum area of the furnace cabinet. (See Figure 3).

10-Installing vent assembly as shown in Figure 4.

11-Secure cabinet front to furnace cabinet using the four (4) screws provided.

INSTALLING VENT TUBE ASSEMBLY **(See Figure 5)**

1-Caulk around the perimeter of the 2 ¼" diameter holes in tire trailer skin, as shown.

2-Position exhaust and intake vent tube assemblies as shown and insert vent assemblies through outer skin and over the exhaust and intake tubes on the furnace.

WARNING! Minimum overlap of ½" is required

3-Secure vent tube assemblies to trailer skin using the #10 x ¾" screws provided.

4-Attach vent tube assemblies to furnace using the special #8 x3" screw provided. (See Figure 5.)

WARNING! Do not omit the special 3" screw. If omitted, the furnace will not be properly anchored to the vent assemblies; therefore, exhaust leakage could occur into living area of coach.

WARNING! Combustion air must not be drawn from the living area; therefore, be sure that the vent tube assemblies have been properly installed, allowing a minimum of ½" overlap of tubes to guarantee that adequate combustion air will be supplied from the outside atmosphere.

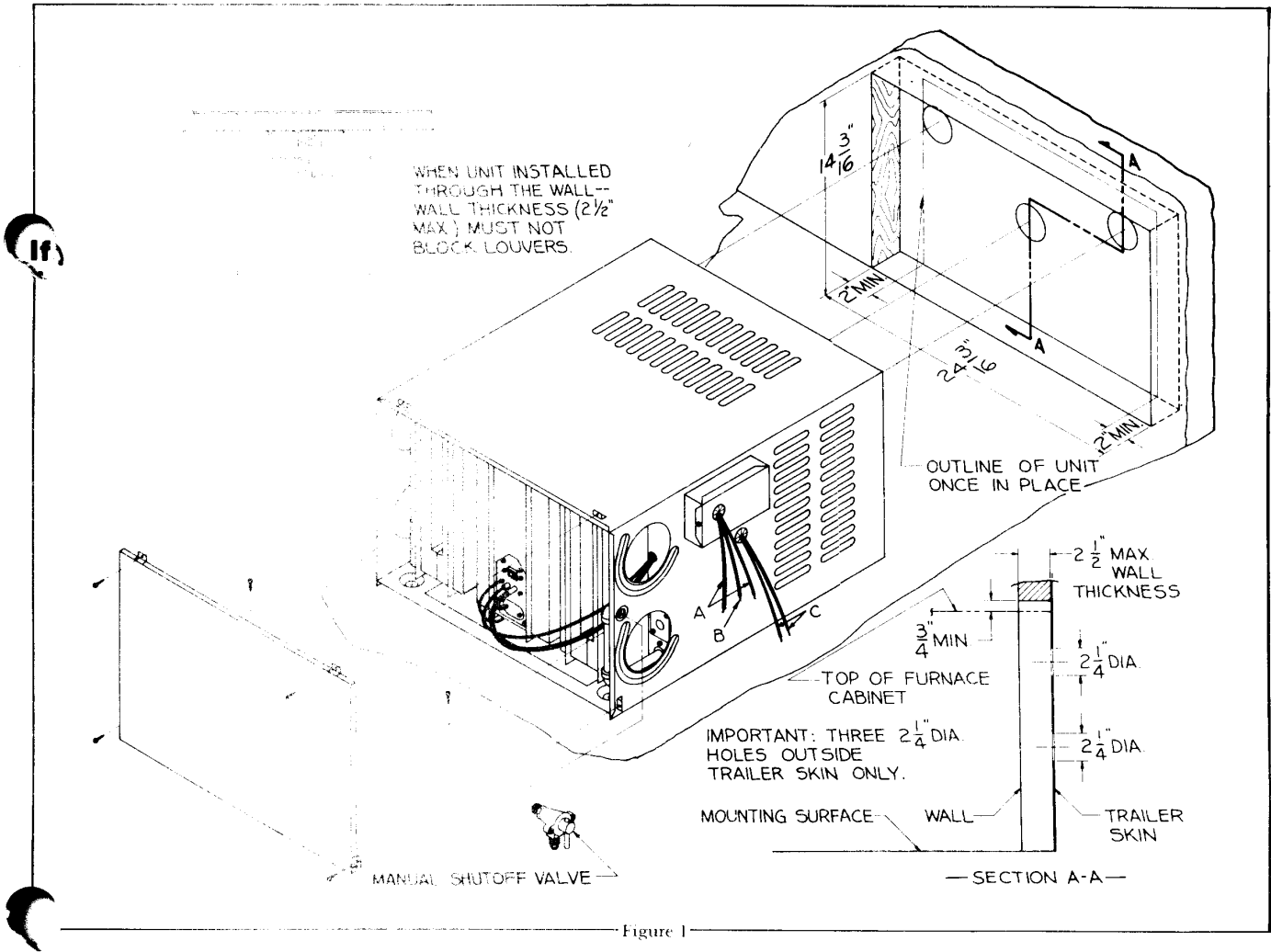
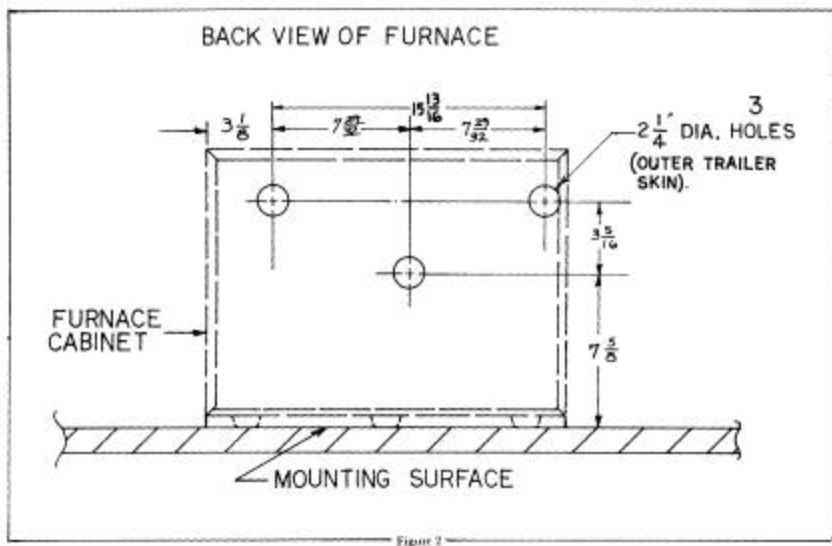

Figure 1



CONNECTING GAS SUPPLY LINE

Install the manual shutoff valve in the supply line to the furnace (See figure 1 or 3). The shutoff valve should be near the furnace and easily accessible. Note: An access door to the manual shutoff valve must be provided.

A drip leg should be installed upstream of the manual shutoff valve exterior to the furnace casing.

Connect the gas supply line to the furnace at the manifold provided on the right side of the furnace (See figure 1 or 3).

WARNING! Compound used on threaded joints must be resistant to liquefied petroleum (LP) gas.

After all connections have been made, check each joint for leaks using a soap and water solution.

WARNING! Never check for leaks with an open flame.

CONNECTING THE ELECTRICAL SUPPLY

Connect the 110-volt AC supply to the black and white wires. (A, figure 1 or 3) at junction box located on right side of furnace cabinet. The green wire (B, figure 1 or 3) is to be connected to ground in accordance with the National Electrical Code ANSI C1-1978.

DUCT SYSTEM

Connect ducts to furnace cabinet. The following duct requirements must be followed in order to assure proper operation of the furnace.

1. Maintain a minimum of 48 square inches duct area in order to keep the furnace from cycling on limit and to assure proper operation of the microswitch.
2. Avoid making a lot of turns in the duct system. The straighter the duct system, the better the performance of the system.

3. Avoid making sharp turns in the duct system. Sharp turns will increase the static pressure in the plenum area and could cause the furnace to cycle.
4. Be sure all duct connections at the furnace are tight. Loose connections will result in overheating of the component parts on the furnace and a reduction of the heated airflow through the duct system.

GENERAL NOTES

1. Locate the room thermostat approximately 4 ½ feet above the floor on an inside bulkhead where it will not be affected by heat from any source except room air. Connect thermostat leads to the two blue wires (C, figure 1 or 3) on the right side of the furnace cabinet.
2. Be sure all wiring to the furnace is of heavy enough gauge to keep voltage drop through it to a minimum. No. 14 gauge wire is recommended. If any of the original wire that is supplied with the appliance must be replaced, it must be replaced with type 105C or its equivalent.
3. After installation, adjustments must be made to obtain a temperature rise within the range specified on the rating plate.
4. To put the furnace in operation, follow the lighting instructions on it. On the initial starting, considerable time may be required to bleed air from the gas supply lines before the spark will ignite the main burner.
5. The efficiency rating of this furnace is a product thermal efficiency rating determined under continuous operating conditions and was determined independent of any installed system.

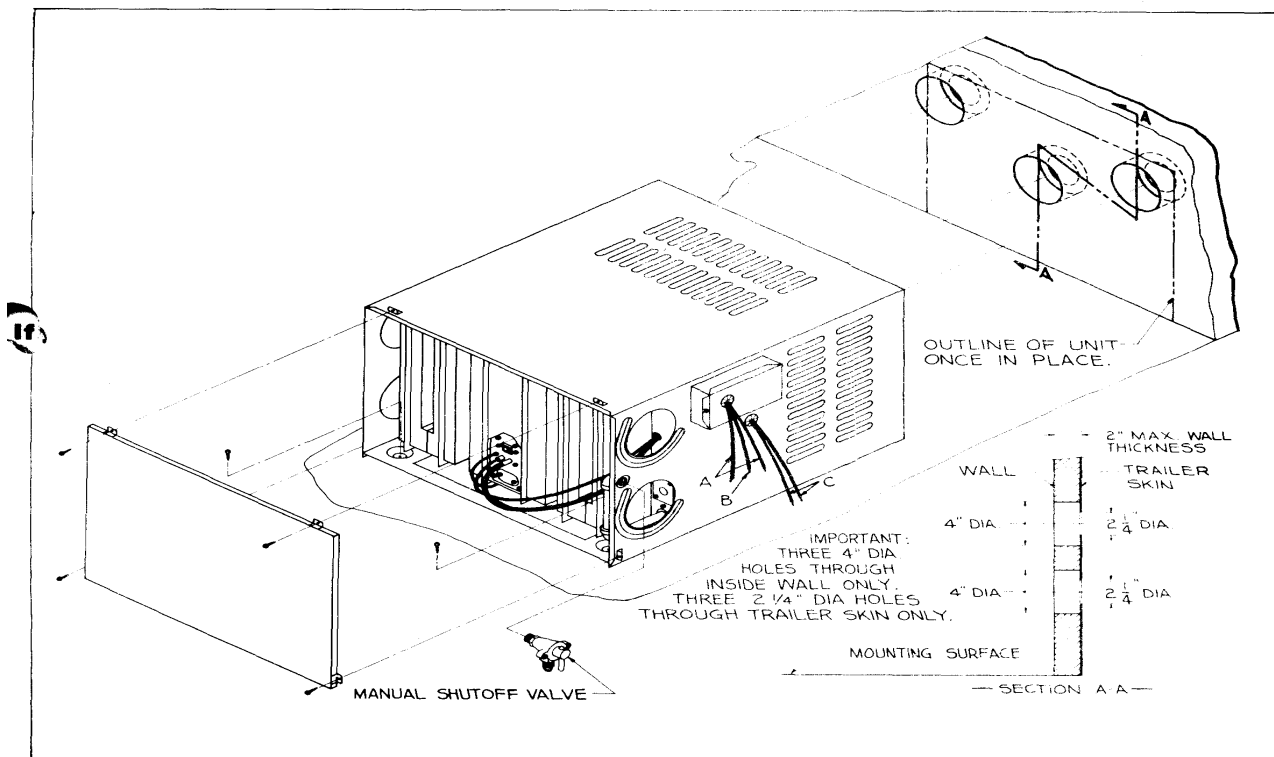

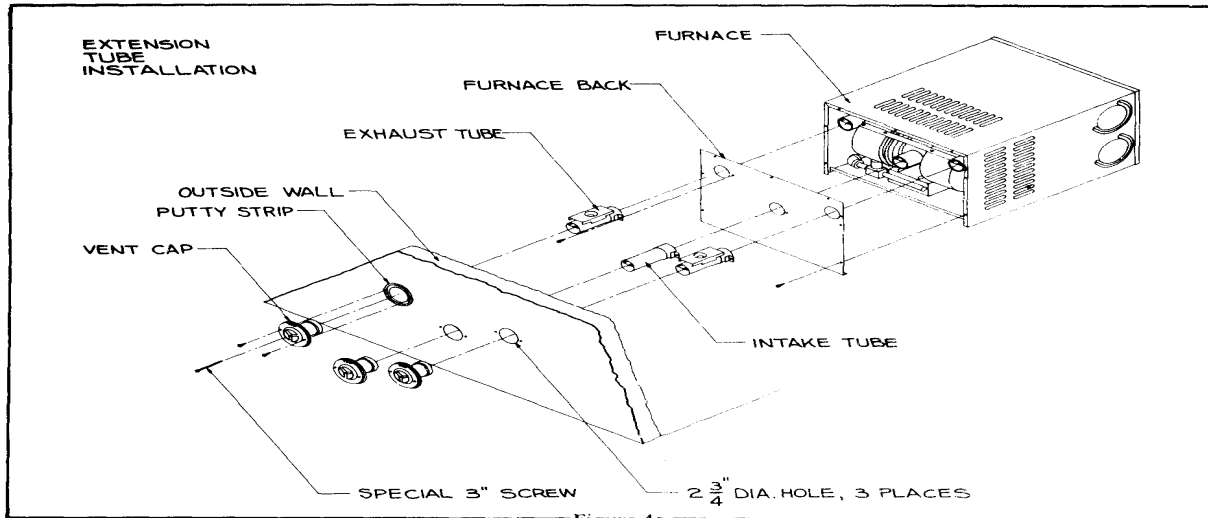

Figure 4

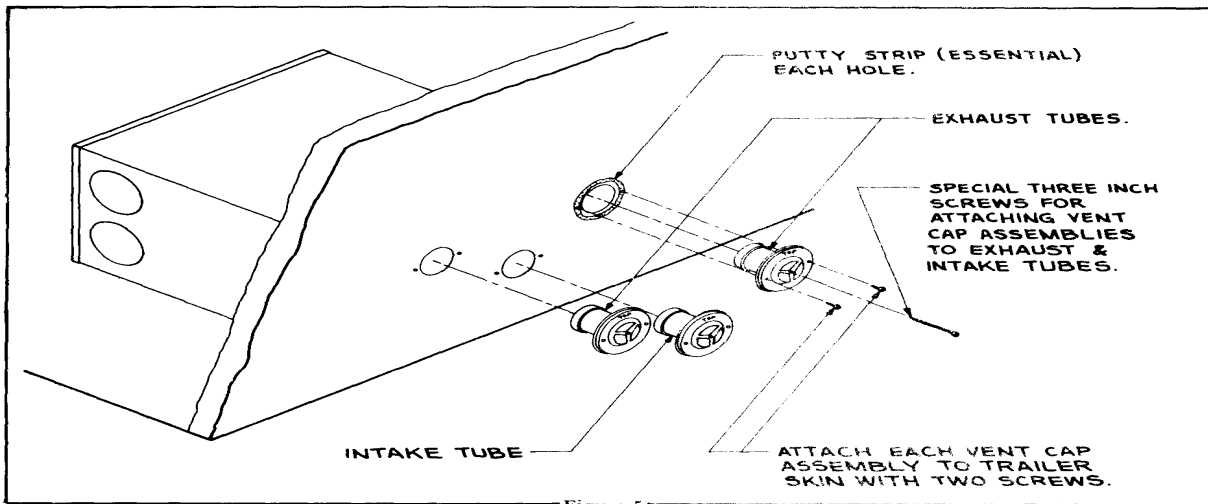

Figure 5

OPERATING INSTRUCTIONS

LIGHTING INSTRUCTIONS

- 1-Remove cabinet front.
- 2-Turn the manual valve to the off position.
- 3-Set thermostat above room temperature. A 10-second delay will occur before the blower starts running.
- 4-Allow blower to run for five (5) minutes for combustion chamber purge cycle.
- 5-After 5 minutes set the thermostat to the *off* position.
- 6-Open manual valve. (Correct operating characteristics depend on if this valve being positioned fully open. Never attempt to operate with valve partially closed.)
- 7-Set thermostat on desired temperature.
- 8-Allow 30 seconds for main burner to light.
- 9-If burner does not light, set thermostat on off and repeat Steps 2 through 8.
- 10-After 3 attempts with no ignition, go to shutdown and determine cause. NOTE: Do not continue to cycle furnace through thermostat in an attempt to get ignition.
- 11-Whenever burner flame is established, replace cabinet front.

TO SHUT DOWN

- 1-Turn manual valve to the off position.
- 2-Set thermostat on off.

SEQUENCE OF NORMAL OPERATION

- 1-When the thermostat calls for heat, a 24volt AC circuit is completed through the coil on the time delay relay. After a 10 second delay, the contacts in the relay close and the blower comes on.
- 2-As the blower motor reaches approximately 75% of the normal r.p.m. (within 1 to 3 seconds), the microswitch, in response to the **airflow**, will engage, allowing current flow to the module board.
- 3-After a 12 - 18 second delay, current will pass through the board to the solenoid valve.
- 4-The current to the valve opens it and allows gas to the main burner. The spark from the electrode then ignites the main burner.

5-After main burner ignition, the flame sensing probe will sense the presence of main burner flame (usually within 7 seconds, and de-energize the lookout feature.

If the main burner does not ignite or the flame sensor does not de-energize, the lookout feature within 7 seconds, the unit will go into lockout. At this time it will be necessary to set the thermostat on off, wait 15 seconds and try again.

6-When the thermostat is satisfied or manually opened, the circuit to the valve is broken and the burner will go off. The blower will continue to run until the coil in the time delay relay cools and opens the contacts in the motor circuit.

NOTE: If main burner ignites and thermostat is satisfied, blower override will be approximately 1-2 minutes. However, if the burner fails to ignite and thermostat is manually opened, blower override will be approximately 30 seconds.

LIMIT SWITCH

The purpose of the limit switch is to turn off the gas to the main burner if for any reasons the furnace becomes hotter than that which is safe. Improper operation of the furnace due to the limit control does not always indicate a defective control. If the circulating air is blocked or only partially so, the limit control will function and cause the main burner to cycle. Cycling on the limit is not always undesirable - if it happens only occasionally. This is a good indication of safe operation and will most likely happen on a warm day. If cycling happens too often or for an extended period of time, the circulating air system should be checked.

If for any reason the limit control is found to be defective, there is no recommended method of repairing it. Because of its importance for safety reasons, it should be replaced with a new one.

WARNING - Never shunt the limit control, even for only temporary operation.

MICROSWITCH

The microswitch has two purposes:

1-It is an air prover. It operates in response to the flow of air generated by the blower. Hence, if for any reason the air from the blower is not sufficient, the switch will not operate. This may be caused by a slow motor due to low voltage, lint accumulation on the blower wheels, a restriction in the return air, or inadequate duct discharge area.

2-The switch allows time for the blower to pull in sufficient amount of air to support combustion before it engages. Once it engages, the ignition circuit is completed.

BLOWER ASSEMBLY

Although one motor drives both the room air blower wheel and the combustion air wheels, the two deliver systems are separated. The combustion air blower is sealed from the living area to prevent any products of combustion from entering. It draws air from the outside atmosphere, discharges it into the combustion chamber and forces the combustion products out the exhaust tube. The room air blower wheels pull return air in and force it across the heat chamber, discharging into the area to be heated.

MAINTENANCE AND CLEANING

Your furnace should be inspected and cleaned before use at least annually by a professional service agent.

A careful inspection of all gaskets should be made and if any gaskets show signs of leakage or deterioration, they should be replaced.

It is imperative that the control compartment, burner and circulating air passageways of the furnace be kept clean. More frequent cleaning may be required due to excessive lint from carpeting, bedding material, etc.

Periodic examination of the venting system should be made. It is important that the flow of combustion and ventilation air not be obstructed.

Circulating air openings in the louvers of the furnace cabinet must not be blocked to permit adequate return airflow. Also, combustion air entering from the rear of the furnace must not be obstructed.

Periodic visual checks of the burners in operation should be made. Figure 6 illustrates the appearance of a correct flame and an incorrect flame. If the primary air should need adjusting, follow the procedures outlined under Burner Adjustment.

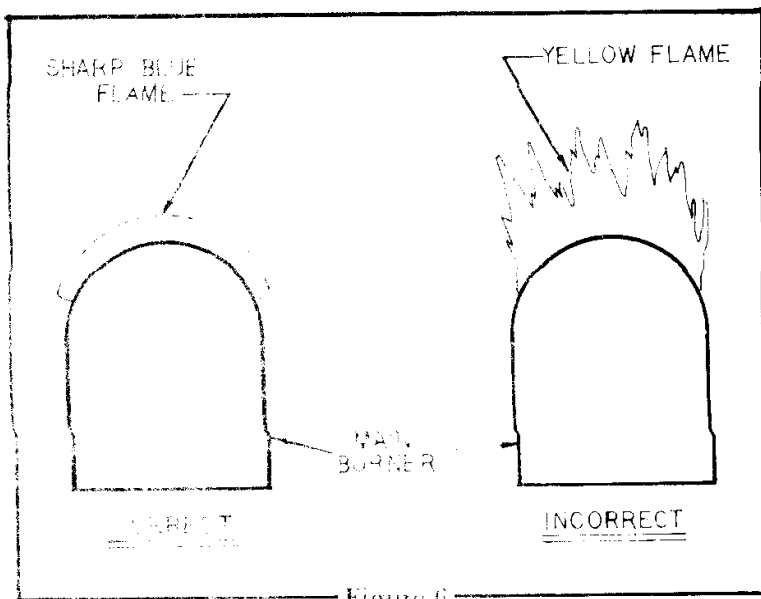

Figure 6

A yellow flame is due to incomplete combustion (lack of air) and will deposit a soot formation inside the chamber and on the main burners. Do not operate the furnace with a high yellow flame. Immediately contact a qualified service agency and have the furnace chamber and burners cleaned. An inspection of the chamber and all gaskets should also be made.

The furnace is equipped with an oiled, sealed motor and requires no oiling.

NOTE: To service the furnace, the combustion chamber assembly must be removed from the furnace cabinet. (See instructions for removing chamber.)

COMBUSTION CHAMBER REMOVAL

The combustion chamber must be removed from the front. Disconnect power supply (right side of cabinet).

2-Disconnect gas supply (right side of cabinet).

3-Remove the vent cap screws on outside of coach to free exhaust Pipe (see Fig. 5).

4-Remove cabinet front.

5-The combustion chamber assembly can then be pulled out of cabinet.

6-To reinstall, reverse above procedure.

BURNER ADJUSTMENT

To adjust the primary air to the burners, the front of the furnace cabinet must be removed. Next, remove the metal cover directly below the electrode assembly on the lower portion of the burner access plate. Behind the cover are two slotted screws, one for the right burner and one for the left burner.

Both burners should be adjusted. Turning the screws clockwise increases the air. Turning the screws counterclockwise decreases the air.

A properly adjusted burner will have a sharp blue flame with well-defined burner ports.

WARNING! If adjusting the burners does not correct a yellow flame or sooting condition, discontinue using furnace and contact a qualified service agency. Cleaning of the burners and chamber is usually required to correct this condition.

SERVICE HINTS, DIAGNOSIS, AND CORRECTIVE MEASURES

A-COMPLAINT-NO HEAT

1-Thermostat off-Check it to be sure thermostat is calling for heat. If the thermostat points are closed, check wiring to thermostat -could be off terminals.

2-Gas supply:

a-Be sure gas is on at tank.

b-Be sure the manual shutoff valve is fully open (handle parallel to gas line).

3-Electrical connections and voltage:

a-Be sure all electrical connections are tight.

b-Check the electrical wiring to the furnace in accordance with unit's wiring diagram.

4-Malfunctioning microswitch-Be sure the microswitch is sailing in far enough to close the contacts. If the switch is not sailing in, clean any dust or dirt from the actuator pin. Other reasons for switch not sailing in are:

a-Insufficient blower speed (Slow motor due to low voltage, minimum - 100 volts AC), faulty motor, lint or dust accumulation on the blower wheels or a restriction in the return air to the furnace.

b-Faulty microswitch- replace switch if it does not show continuity when manually engaged. Switch should also be replaced if blower running at top speed fails to engage switch within 3 to 5 seconds.

c-Inadequate ducting-see duct requirements under duct system.

5-Limit switch-Switch should show continuity. If not, replace switch.
(Do not shunt the limit switch)

6-Gas valve- Within 30 seconds after motor reaches 75% of its r.p.m. and microswitch engages, check the following:

a-Voltage at valve-if voltage is present but valve is not opening, check wire connections in valve circuit.

b-wire connections ok-replace valve.

7-Blower not operating-Possible causes:

a-Check power supply to furnace.

b-Check electrical connections at furnace.

c-With thermostat points closed, check for circuit completion at motor.

1-If voltage is present, replace motor.

2-If no voltage is present at motor, check for:

a-24 volts on secondary coil of transformer. No voltage-replace transformer.

b-24 volt transformer ok-check for circuit completion across contacts on time delay relay. Allow 3-5 seconds for contacts to close. No circuit across contacts- replace relay.

c-Circuit across contacts ok-check continuity of wiring in motor circuit.

8-Short cycling (motor goes off and on)

a-Check thermostat-contacts should remain closed. If contacts are breaking:

1-Check to be sure correct thermostat is being used - it should have a .85 amp anticipator.

2-Correct thermostat being used, check for shorts in thermostat wiring.

3-Wiring OK - replace thermostat.

b-Thermostat contacts are remaining closed:

1-Check to see if voltage is present at motor when it goes off. If voltage is present, replace motor.

2-No voltage at motor, check for circuit completion across contacts on time delay relay.

3-Relay OK, check wiring to motor for possible shorts, loose connections or broken wires.

4-No circuit across contacts on time delay relay, check secondary coil of transformer for 24 volts AC

5-No voltage - replace transformer.

6-Voltage OK -check wiring and wire connections through thermostat and time delay relay.

7-Wire connections and wiring OK - replace time delay relay.

9-Ignition Failures- Cautions:

- a-Never operate the furnace neither with the electrode wire disconnected nor with the electrode assembly removed from the furnace.
- b-Never use a screwdriver on any part of the electrode assembly while the furnace is in operation.
- c-Be certain that the spark from the electrode never reaches the flame sensor portion of the electrode assembly as it could damage the module board.
- d-Be sure the electrode assembly screws and electrode ground wire screws are snug at all times, especially after the electrode has been removed and reinstalled.
- e-If the module board is found to be defective, it must be replaced - it is **not field repairable!**

WARNING! Any attempts to repair the board may alter the board and cause it to operate in an unsatisfactory manner.

f-Insure that the gap between electrode and ground is always 1/8". The gap between the ground and the flame sensor should be approximately twice the gap between electrode and ground to assure no sparking to sensor. Sparking to sensor could damage module board. (See Fig. 7)

The electronic ignition system is made up of three main parts - the module board, the electrode assembly and the electrode wire. The module board is the brain of the electronic ignition system and it has several functions:

1-When the blower reaches approximately 75% of the normal r.p.m. and sufficient airflow is established, the microswitch engages and completes a circuit through the limit switch to the module board. 2-After a 12 - 18 second delay, current will pass through the module board to the solenoid valve. The current to the valve opens it and allows gas to the main burner. Simultaneously, the module board sends high voltage through the electrode wire to the electrode assembly. The voltage seeks a ground between electrode and ground probe and a spark occurs. The spark ignites the main burner.

3-The module board also performs the lockout function in cases where the spark fails to light the burner. When lockout occurs, the spark stops and the voltage from the module board to the gas valve is discontinued and the valve closes. The unit will remain in lockout and the blower will continue to run until the thermostat is turned off. Turning the thermostat off engages the lockout function of the module board and after the blower has stopped, the ignition sequence can be started again.

It is important to determine the type of problem being experienced and then the proper checkout procedure can be made. The following is a list of problems, how to identify in which area the problem is located, and how to correct it:

1-Electrode not sparking-with blower running and microswitch engaged, check the following:

a-Check for voltage at module board across red and yellow wires after the blower motor reaches full rpm. If no voltage, check continuity through microswitch and limit switch. Also check wire connections.

b-voltage is present but no spark at electrode after 12-18 second delay, check electrode wire connections.

c-wire connections ok but electrode wire does not show continuity through it – replace electrode wire.

d-electrode wire does show continuity through it – check electrode gap. (See Fig. 7)

e-electrode gap ok-check electrode assembly for possible cracks or carbon on tip of electrode.

f-check green ground wire at electrode assembly to be sure it is securely attached to the electrode mounting screw and the burner mounting screw.

g-Ground ok-replace module board.

2-Electrode sparking but gas not coming through burner:

a-check to see if voltage is coming out of module board to gas valve after 12-18 second delay. Check the wires in the Molex connector to be sure they are intact and making contact with the module board. Check the brown wire from the module board to valve for continuity. Wire and connections check ok-replace module board.

b-voltage present at valve but gas valve not opening-replace gas valve.

3-Electrode sparking and gas valve opening but burner will not light:

a-check to see if gas is coming through burner. If no gas is coming through burner,

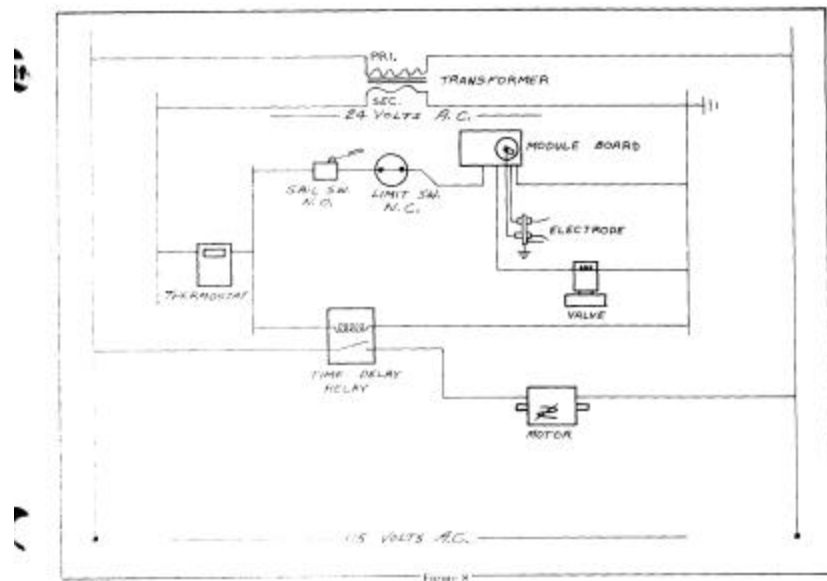
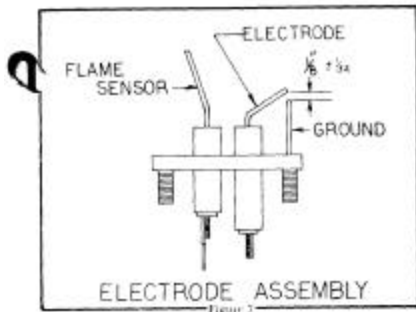

check for obstruction in gas line, in main burner orifice, or in main burner.
b-Gas is coming through burner but spark will still not ignite burner -check gas pressure.

Line Pressure

LP Gas - Minimum-1 I" W.C. / Maximum-14"W.C.

Natural Gas - Minimum-5"W.C. / Maximum-7" W.C.

Operating Pressure

LP Gas - Minimum 10.5"W.C. / Maximum 13.5" W.C.

Natural Gas - 3.5" W.C.

To properly check pressure, determine the line pressure, cycle furnace and check pressure drop on demand. The drop in pressure should not be more than ~1" W.C. A drop of more than ~1" would indicate a faulty regulator, a restriction in the gas line or a pinched gas line.

c-Gas pressure OK - check for obstruction in main burner, check for proper air adjustment on main burner (see instructions for adjusting burner), check to be sure electrode is positioned approximately 1/4" above and directly over one of the sawed slots on the main burner. d-Check all gaskets to be sure they are tight and forming a good seal.

4-Burner ignites but goes off and into lockout:

a-Check to be certain that flame sensor is positioned in the inner blue cone of the main burner flame and that the main burner flame is burning against the tip of the flame sensor - adjust by bending sensor probe. *NOTE: Sensor probe will be approximately 1/4" - 5/16" above burner.*

b-Burner still goes off and into lockout, check wire connections at flame sensor and at module board.

c-Wire connections OK -check continuity through flame sensor wire.

d-Continuity of flame sensor wire OK - check with micro amp meter in series with flame sensor wire to be certain that the flame sensor is generating at least seven micro amps within seven seconds after the burner is ignited. Connect meter as follows: (+) to sensor wire, (-) to sensor probe. Adjust position of sensor probe, check air adjustment on main burner and check for carbon deposits on sensor probe if reading is less than 7 micro amps.

e-Flame sensor circuit generating at least 7 micro amps but burner still goes off and into lockout, replace module board.

5-Repeated module board failures:

a-Check to be certain that the electrode spark is not sparking against the flame sensor portion of the electrode assembly. (See Figure 7 for correct gapping.)

b-Check to be sure module board or high voltage wire is not shorted to the chamber wrapper or other furnace parts.

c-Be sure insulator covering the wire connection on the coil of the module board is in place.

d-Check for high voltage - 30 volts AC maximum.

e-De sure duct connections to furnace are tight. Seal duct connections to furnace cabinet with duct tape, if necessary, to prevent hot air leakage- No air leakage should exist anywhere in the duct system, especially at connections on cabinet.

f-Be sure ground wire at electrode assembly is securely attached to the electrode assembly and the burner mounting screw.

6-Customer complains of intermittent lockout:

a-Thoroughly check electrode and burner air adjustments.

b-Be sure burner is burning with a sharp blue flame from front to rear of burner. Clean burner as required.

c-Lockout can occur if the gas pressure fluctuates at the time that the thermostat calls for heat. Pressure fluctuations can be caused by a malfunctioning gas bottle regulator, an obstruction or a kink in the gas bottle regulator or in the gas lines.

It is difficult to check for these fluctuations that will not noticeably affect any other appliance in the coach. However, isolating the furnace from the coach gas system will determine if the gas system is responsible. This isolation procedure can be done by connecting a separate upright bottle, regulator and gas line directly to the furnace, eliminating the coach gas system. If the occasional lockout still exists, then the furnace should be thoroughly tested to determine the cause; however, if the furnace works properly on this separate system, then the coach gas system should be checked.

d-Check furnace return air and ducting to be sure sufficient airflow is present to consistently engage microswitch.

e-Check microswitch to be sure it moves freely.

When moisture in the gas system is suspected as being the problem, especially where the horizontal type gas bottle is being used, the following steps should be taken to prepare the gas system against further moisture problems.

Corrective Measures:

1-Disconnect gas bottle and drain it completely dry of all gas and moisture.

2-Disconnect and blow out all gas lines completely dry. 3-Install a new pressure regulator on the gas bottle.

4-Add the drying agent. 1/2 pint of methanol alcohol per 100 pound bottle capacity is recommended.

5-Never fill the gas bottle over 80%.

6-Do not use gas bottle completely dry to avoid using up the drying agent.

We have found the above procedures to be effective in over 95% of all occasional lockout problems. All of these steps must be performed as described for the preparation of a contaminated gas system to be 100% effective.

B-COMPLAINT-EXCESSIVE NOISE

1-Blower out of balance - replace blower wheels or motor.

2-Motor hum - replace motor.

3-Air adjustment - a screeching or howling noise while burner is on is due to excessive primary air. To adjust for less air, see instructions under *Burner Adjustment*.

C-COMPLAINT-ERRATIC BLOWER OPERATION

1-If blower is going off and on, check the following:

a-Thermostat points - if points are opening and closing, see *Service Hints*, line 2 below.

b-If thermostat points are remaining open or closed, the internal overload switch in the motor may be defective. If voltage is present at motor whenever motor goes off - replace motor.

2-If thermostat points are observed opening and closing rapidly when furnace first starts, check the following:

a-Shorted gas valve - if furnace runs properly with wires at gas valve disconnected, replace gas valve.

b-Short in wiring - check all connections including thermostat.

c-Incorrect thermostat being used. Thermostat should have a .85 amp anticipator.

D-MAIN BURNER WILL NOT CYCLE OFF

I-Check thermostat points - points should break cleanly.

2-Check solenoid valve - valve may be stuck open, if so, replace valve.

Do not attempt to repair valve.

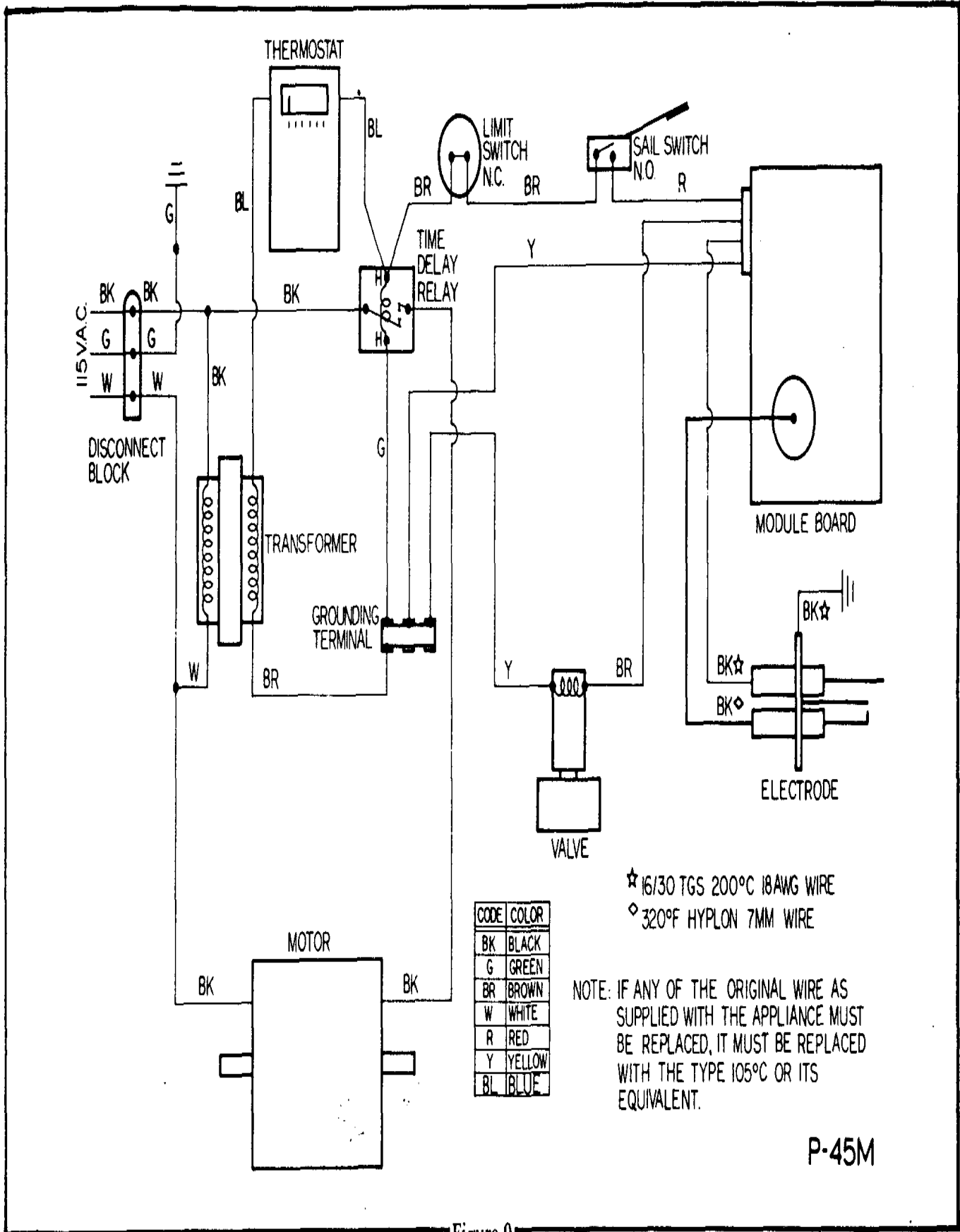

P-45M

Figure 9

Limited Warranty
RECREATIONAL VEHICLE HEATING UNIT

Suburban manufacturing Company (SUBURBAN) warrants to the first purchaser, **the heating unit against defects in material and workmanship** under normal use for a period of one year from date of first purchase **of the recreational vehicle**. The heat exchanger is warranted to the first purchaser against rustout and burnout for a period of 5 years from date of first purchase of the recreational vehicle. Warranty parts will be replaced at no charge for the parts. Labor will be paid only as set forth in the Service Policy below.

SERVICE POLICY

Suburban Manufacturing Company, with the cooperation of its authorized service centers, will endeavor to assure customer satisfaction. If a defect of material or workmanship in the heating unit is repaired within one year from date of original purchase, Suburban will pay a service allowance to the authorized service center up to the maximum specified under the terms of Suburban's contract with the service center. To obtain repairs or replacements, the owner/user must provide for transportation of the heating unit to and from the service center and must inform the service center of the nature of the defect. A list of authorized service centers is enclosed with Suburban's Installation, Operating and Service Instructions book. The owner/user may obtain an updated list of authorized service centers from Suburban Manufacturing Company at any time. Any warranty labor charges paid by the owner/user will be reimbursed at Suburban's Flat Rate Labor Schedule in effect at time repairs were made. Any parts replaced under warranty and paid for by the owner/user must be returned to the factory for inspection. Reimbursement for parts will be made only at dealer price in effect at time parts were replaced. All repairs made after one year from date of original purchase will be at the expense of the owner/user.

EXCLUSIONS AND LIMITATIONS

A-There are no other express warranties except as set out above, and any implied warranties are limited in duration to one year from date of first purchase of the recreational vehicle. Some states do not allow limitations on how long an implied warranty lasts, so the above limitation may not apply to you.

B-This Limited Warranty excludes consequential damages, incidental damages, or incidental expenses, including damage to property. Some states do not allow the exclusion or limitation of incidental or consequential damages, so the above limitation or exclusion may not apply to you.

C-This Limited Warranty (does not cover damages caused by improper installation, mishandling, neglect, abuse, improper energy supply, other circumstances beyond Suburban's control such as fire, flood or other acts of God, or operation of the heating unit contrary to the provisions of the Installation, Operating and Service Instructions book of Suburban or contrary to proper voltage and fuel ratings as design certified by the American Gas Association.

D-Certain services are not included under the Service Policy. They are:

I-Initial checkout and subsequent checkouts which determine that the furnace is operating properly.
2-Cleaning. 3-Water or dirt in controls, fuel lines, and gas tanks. 4-Broken or shorted wires. 5-Restriction or alteration of warm air or return air circulation. 6-Thermostat adjustments. 7-Instructing owners in operation. 8-Adjusting primary air. 9-Pilot adjustment. 10-Electrode adjustments. 11-Clogged orifice. 12-Disconnected wires. 13-Broken parts. 14-Charges incurred in gaining access to the furnace.

No representative or person is authorized to assume for Suburban Manufacturing Company any other liability in connection with the sale of this recreational vehicle furnace.

This warranty gives you specific legal rights and you may also have other rights which vary from state to state.

SUBURBAN MANUFACTURING COMPANY
Post Office Box 399 Dayton, Tennessee 37321