

DUO-THERM

OWNERS MANUAL FOR 66000 SERIES FURNACES

Gas-Fired Fan Type Direct Vent Wall Furnaces For Recreational Vehicles

DIRECT SPARK IGNITION MODELS

FOR YOUR SAFETY

If You Smell Gas:

1. Open windows.
2. Don't touch electrical switches
3. Extinguish any open flame.
4. Immediately call your gas supplier.

Clothing or other flammable material should not be placed on or near the appliance

FOR YOUR SAFETY

Do not store or use gasoline or other flammable vapors and liquids in the vicinity of this or any other appliance.

CAUTION

Modification of this Appliance can be extremely Hazardous. Always consult the manufacturer before making changes.

Children and adults should be alerted to the hazards of high surface temperatures and should stay away to avoid burns or clothing ignition.

Young children should be carefully supervised when they are in the same room as the appliance.



READ THESE INSTRUCTIONS CAREFULLY, KEEP FOR FUTURE REFERENCE.

OPERATIONAL CHECKOUT - DIRECT SPARK IGNITION MODELS

IMPORTANT: Failure to follow these lighting instructions exactly may result in damage to the unit.

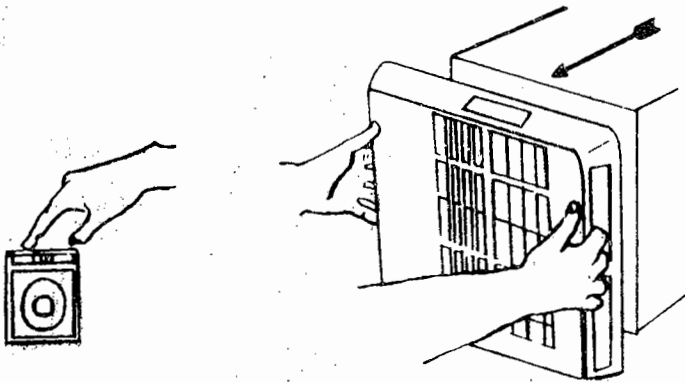

1. Set thermostat to "OFF" position. Remove furnace front panel by pulling straight out.

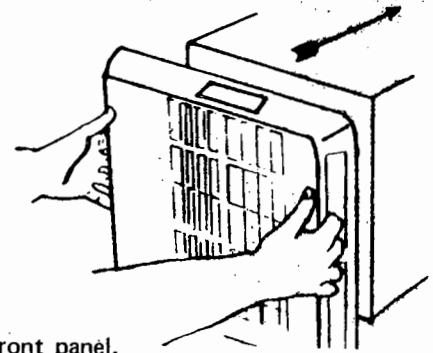

4. Replace furnace front panel.

5. Set thermostat at desired temperature. Furnace will now operate automatically.

When the thermostat calls for heat a delay of up to 30 seconds will occur before the fan motor is energized.

6. Allow 15 seconds for burner to ignite.

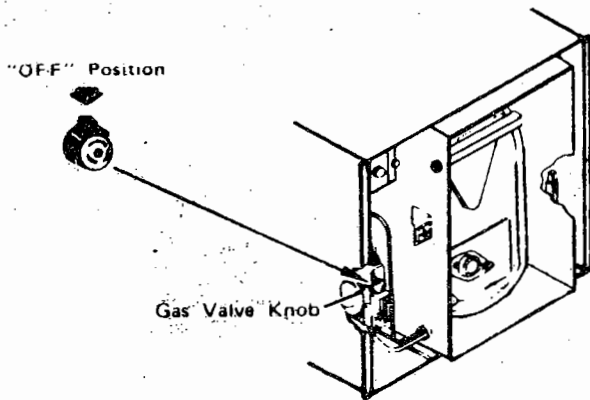

2. Turn gas valve knob to "OFF" position. Wait 5 minutes.

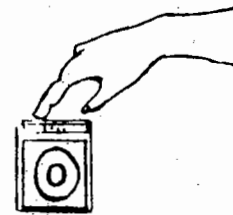

7. If burner does not light, set thermostat on "OFF" position. Wait 45 seconds. Repeat steps 3 through 6.

8. If ignition is not obtained after three tries, go to complete shut-down and determine cause.

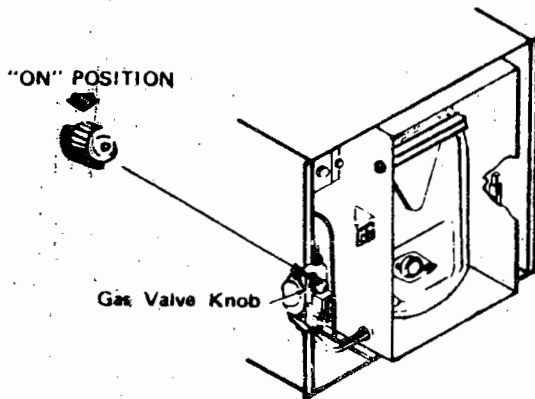

3. Turn gas valve knob to full "ON" position. Correct operation of the unit depends on this valve being in the full "ON" position. Never attempt to operate the unit with valve partially closed.



FOR COMPLETE SHUT-DOWN, TURN GAS VALVE KNOB TO "OFF". SET THERMOSTAT TO "OFF" SETTING.

SEQUENCE OF NORMAL OPERATION

1. When the thermostat calls for heat a delay of up to 30 seconds will occur before the fan motor is energized.
2. As the fan motor reaches approximately 75 percent of its normal r.p.m. (within 1 to 2 seconds) the combustion air switch, in response to the air flow, will engage, allowing current flow to the gas valve.
3. The gas valve will open and allow gas to the main burner. The spark produced from the ignitor electrode ignites the main burner.
4. When the thermostat is satisfied or turned back, the gas valve will close and the flame on the main burner will go out. The blower will continue to run for a short period of time and will then shut off. The purpose of this is to remove most of the remaining gases and heat from the heat exchanger.

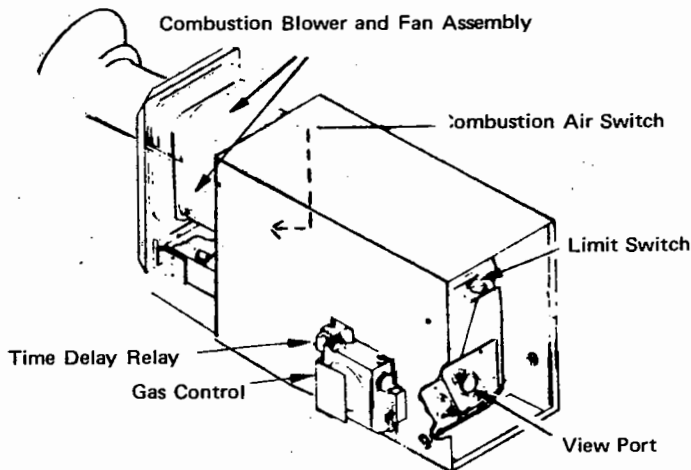

TIME DELAY RELAY

This relay is to control the sequence of the blower operation. When the bimetal disc of the relay is heated internally to the operating temperature, the switch closes. This completes the circuit to the motor. The blower will continue to run as long as the relay is hot even though the thermostat is satisfied and the main burner is off. When the relay sensor cools, the switch opens and shuts the blower off.

LIMIT SWITCH

The purpose of the limit control is to turn off the gas to the main burner if for any reason the furnace becomes hotter than that which is safe. If the circulating air is blocked, even partially, the limit control will function and cause the main burner to cycle. If cycling of the limit control occurs, the circulating air passage should be thoroughly cleaned.

If the limit control is found to be defective, it cannot be repaired. It must be replaced with a new one. **CAUTION: NEVER SHORT ACROSS OR BYPASS THE LIMIT CONTROL EVEN FOR ONLY TEMPORARY OPERATION.**

AIR SWITCH

The combustion air switch has two purposes :

1. It is an "air prover". It operates in response to the flow of air generated by the fan. Hence, if for any reason the air from the fan is not sufficient, the switch will not operate. One cause of insufficient air is a slow motor caused by low voltage.
2. The switch allows time for the blower to pull in a sufficient amount of air to support combustion before it engages. Once it engages, the gas valve opens, gas flows to the main burner and ignition occurs.

BLOWER ASSEMBLY

One motor is used to drive both the combustion air wheel and the circulating air fan blade. Although one motor drives both, the wheel and fan blade are separate. The combustion air blower is sealed so as to allow no passage of air between it and the circulating room air fan. The combustion air blower draws air from the outside atmosphere, discharges it into the combustion chamber, and forces the combustion products out the exhaust tube. The circulating room air fan blade pulls return air in and forces it across the heat chamber discharging it into the area to be heated.

MAINTENANCE AND CLEANING

NOTE: For continued satisfactory performance of this unit it is necessary that the control compartment be kept clean. It is also important that the appliance area be clear and free of combustible materials, vapors and liquids.

If the main burner has been allowed to operate with a high yellow flame, a soot formation may be deposited inside the combustion chamber. The carbon deposit may be of such quantity that cleaning will be necessary. A vacuum cleaner is ideal to clean out any carbon deposit in the combustion chamber.

Routine inspection, maintenance and cleaning of burner, venting system and gas connections is recommended at least on a yearly basis.

This unit is equipped with sealed motor and requires no oiling.

The main burner should be examined periodically to be sure that a distinct blue mantle is visible and that bright yellow tips are not evident. See diagram Below.

MAIN BURNER

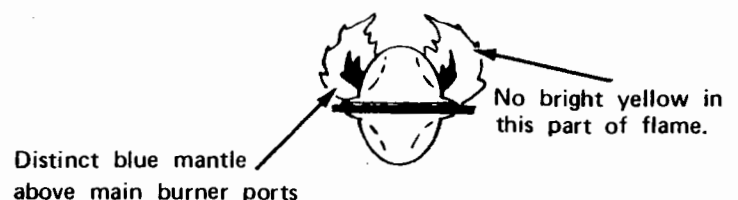

TO REMOVE HEATING ASSEMBLY

1. Remove the furnace front panel by pulling straight out.
2. Disconnect wiring circuitry at the convenience disconnect plug.
3. Disconnect gas supply. (Be sure gas supply to the unit is turned off).
4. Remove 3 screws securing heat assembly to cabinet.
5. Remove the vent cap screws (outside) to free vent-air terminal.
6. Pull assembly forward.

HEATING ASSEMBLY REMOVED

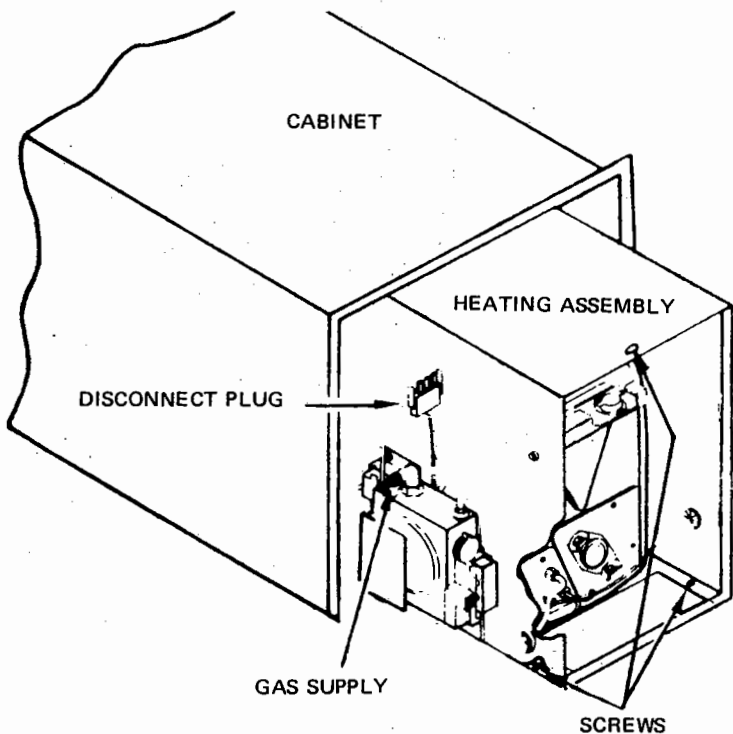

TO REMOVE BURNER

1. Remove nuts holding close off plate.
2. Remove close-off plate.
3. Rotate ratchet clip until tabs are accessible. Compress tabs and slip off burner mounting pin.
4. Raise burner off mounting pin and remove.
5. Burner orifice may now be serviced with long extension and a 1/8" socket.

TO REPLACE BURNER

1. Center orifice end of burner over orifice, slide outer end over burner mounting pin.
2. Slide ratchet clip over burner mounting pin until it is firm against burner.
3. Replace close-off plate and secure with nuts.

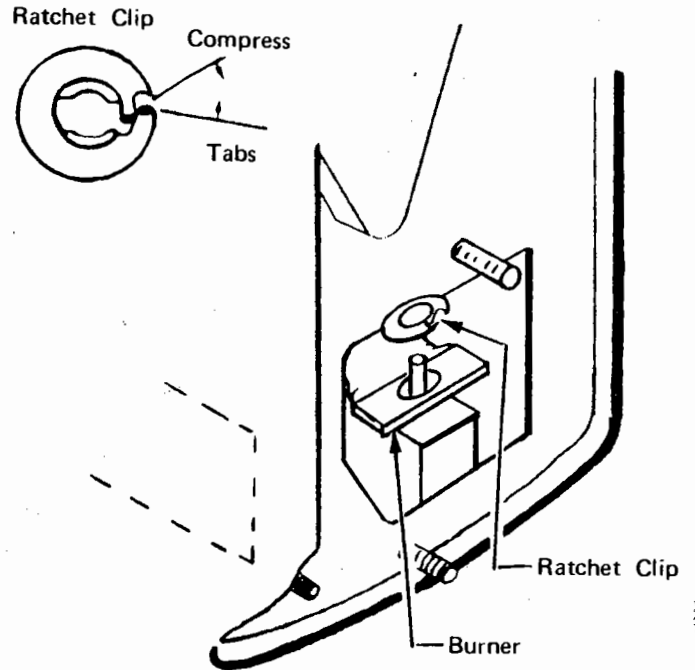

SERVICE HINTS, DIAGNOSIS AND CORRECTIVE MEASURES

INSTALLATION AND REPAIR SHOULD BE DONE BY A QUALIFIED SERVICE PERSON. THE APPLIANCE SHOULD BE INSPECTED BEFORE USE AND AT LEAST ANNUALLY BY A PROFESSIONAL SERVICE PERSON. MORE FREQUENT CLEANING MAY BE REQUIRED DUE TO EXCESSIVE LINT FROM CARPETING, BEDDING MATERIAL, ETC., IT IS IMPERATIVE THAT CONTROL COMPARTMENTS, BURNERS, AND CIRCULATING AIR PASSAGEWAYS OF THE APPLIANCE BE KEPT CLEAN

A. COMPLAINT - No Heat

1. Check electrical supply to make sure that 12 volt d.c. is available at unit. Battery must be charged. If battery is low, there may be sufficient power to run the blower, but not enough to run the blower at full speed. If blower does not run at it's prescribed speed, the combustion switch cannot engage and gas will not flow to the main burner. Be sure the connections to the voltage lines in the terminal block are tight.

2. Check fuse located in electrical box. These furnace use an automotive 4.0 amp AGC glass tube fuse, purchased locally.

SHORT CIRCUIT CHECKOUT

If fuses are blown either in the furnace or vehicle a short is indicated and should be checked.

3. A. Turn off all appliances including furnace.
B. Install an ammeter on the positive (+) lead of the battery. Amperage reading should be 0. If an amperage reading is noted, a short exists in the vehicle electrical system.
C. Disconnect the red (+) DC lead at the furnace. If the amperage continues, the short is exterior to the furnace. If the amperage reading ceases, the furnace electrical system is shorted and should be checked.

4. GAS SUPPLY - Be sure manual gas valve is in the open position.

5. THERMOSTAT OFF - Check to be sure thermostat is properly wired and is calling for heat.

6. MALFUNCTIONING COMBUSTION AIR SWITCH - Be sure the combustion air switch is moving far enough to close its contacts. If the switch is not closing, clean any dust or dirt from the actuator pin. Other reasons for switch not operating are:

- A. Insufficient fan speed (slow motor due to low charged battery, faulty motor or lint and dust accumulation restricting return air to furnace). Check wiring in accordance with unit's wiring diagram to assure that the proper polarity of the 12 volt d.c. power supply is observed. On certain models this polarity must be observed so the motor will run the proper direction of rotation to insure correct air delivery.

- B. Faulty combustion air switch - Replace switch if valve does not open when switch is engaged. Switch should also be replaced if battery is fully charged and with the fan motor running at top speed the switch fails to engage within 3 to 4 seconds.

NOTE: To service switch, heating assembly must be pulled out.

7. GAS CONTROL VALVE - With test light check valve terminals. If voltage is present, but valve is not opening (when combustion air switch engages), replace control valve.

8. FAN NOT OPERATING - Check for burned-out motor or loose wiring terminals.

9. DEFECTIVE FAN RELAY - Relay may be at fault if motor fails to start when thermostat calls for heat. This can be suspected if the thermostat is raised and the motor fails to operate within 60 seconds.

B. COMPLAINT-EXCESSIVE NOISE

1. Motor or blade out of balance. Replace motor or blade.
2. Motor Hum. Replace Motor.

C. COMPLAINT-ERRATIC FAN OPERATION

A loose terminal or a defective relay may cause the motor to cycle off while the thermostat is calling for heat, an outage will occur because the blower is not purging the system of combustion products.

D. COMPLAINT-UNIT WILL NOT OPERATE

1. Check for power to the unit.
2. Check fuses.
3. Check all wiring to assure proper connections or detect possible shorts.
4. Manually rotate fan to see if assembly is free to turn.

THERMOSTAT ADJUSTMENT

This unit is equipped with an adjustable thermostat. Improper setting of the heat anticipator can cause either abnormally short or long heating cycles resulting in discomfort.

For correct heating anticipator adjustment, proceed as follows:

Cycle system to determine if cycling rate is satisfactory. If adjustment is necessary, move pointer to a higher setting for longer "ON" cycle and to a lower setting for shorter "ON" cycle.

Suggested normal settings:
66000 Series (Direct Spark Ignition) .8

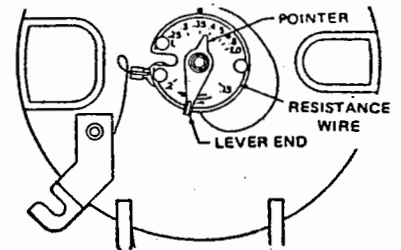

HIGH ALTITUDE DERATION

These units are designed for optimum efficiency from 0 to 4500 feet above sea level. As with any gas appliance with this design factor, the gas input to the burner should be reduced 4% for each 1000 feet above sea level when the unit is used at elevations above 4500 feet.

If the unit is not properly derated the following conditions will exist:

1. Due to the lack of sufficient oxygen for proper combustion, carbon monoxide will be produced and exhausted through the vent. Entry of these fumes into the vehicle (due to improper installation of the vent or through another opening in the vehicle exterior) could create a hazardous condition which could endanger the life of anyone exposed to these fumes for a prolonged period of time.

2. Due to incomplete combustion of LP gas at the burner, the actual heat output of the furnace will be considerably less than the rating of the unit. Fuel which is not burned will be wasted.

If the unit is properly derated, it will produce approximately the same amount of heat at higher elevations, but will do so with considerably less fuel.

The following chart lists recommended orifice sizes for various altitudes:

ALTITUDE IN FEET	66012 ORIFICE SIZE	66017 ORIFICE SIZE
0-4500	61	56
5000	64	57
6000	64	58
7000	65	58
8000	65	59
9000	65	59
10000	66	61
11000	67	61
12000	67	63

Also, check gas pressure when derating unit. First, check piping system pressure and adjust to 11" w.c. at tank regulator (NOTE: If this pressure check is made at cooktop or range be sure that there is not pressure regulator present, or an incorrect reading will be obtained.) Then check manifold pressure at the pressure tap location on the outlet end of the gas control on the furnace. Adjust to 10.5 w.c. by rotating the adjustment screw (located under a screw cap, marked "Press Adj") on gas control.

DIRECT SPARK IGNITION

To ignite the burner, it is necessary only to set the thermostat. The thermostat powers the ignitor to simultaneously open the main burner valve and provide the ignition spark. As soon as the flame is established, the spark ceases. Should the flame not be established within a period of 15 seconds, the system provides safety shut down.

Electronic flame sensing circuitry in the ignitor detects the presence or absence of main burner flame. If the flame is not established during the Flame Establishing Period, the system closes the gas valve and locks out. If the flame is extinguished during the duty cycle, the ignitor will provide one retry for ignition, before going into lock-out. To reactivate or retry for ignition, follow the procedure outlined under "OPERATION - AL CHECKOUT - DIRECT SPARK IGNITION MODELS".

2. DESCRIPTION

The direct spark ignition system consists of a solid state printed circuit control module, an electrode assembly and connecting high and low voltage wires.

3. REPAIRS

The solid state control module is not field repairable. Any modifications or repairs will invalidate the warranty and agency certifications.

WARNING: DO NOT APPLY POWER TO CONTROL MODULE UNLESS WIRING CONNECTIONS ARE COMPLETE AND ELECTRODE IS PROPERLY GROUNDED.

CAUTION: HIGH VOLTAGE

4. SYSTEM CHECKS

- A. Input polarity - if a spark is present and the gas valve opens but the system shuts down after the trial period, check input voltage for proper polarity.
- B. Grounding - it is essential to proper operation that the system be properly grounded. If a spark is present and the gas valve opens but the system shuts down after the trial for ignition period, check for proper ground. The following items should be checked:
 1. Green wire to Liner Side.
 2. The burner must be secure.
- C. Wiring - check all wiring for proper and secure connections. Be sure the AMP connector is fully engaged in the control board. Check the high voltage wire for proper connection at both ends. Clean any corrosion that may interfere with good electrical contact
- D. High Voltage Malfunction - if during the trial for ignition, the spark is intermittent and the valve may or may not open, the following should be checked:
 1. Electrode spark gap - should be 1/8" ± 1/32".
 2. Ceramic housing - check for cracks.
 3. Electrode lead wires - check for cracks or breaks.
- E. Valve Malfunction - if there is power to the control module and a spark during the trial for ignition, but the valve will not open, check the valve for an open coil or other malfunction.
- F. Erratic Operation - if the system operates properly for a period of time but randomly shuts down during the duty cycle, or will not operate during cold starts, check the flame proving circuit (sensor wire) with a D.C. Microamp Meter. The current should be 5 - 15 microamps. A low or marginal flame current may cause nuisance tripping. If this condition is experienced, the electrode location should be checked to make sure the sensor electrode is in the flame.

WIRING DIAGRAM

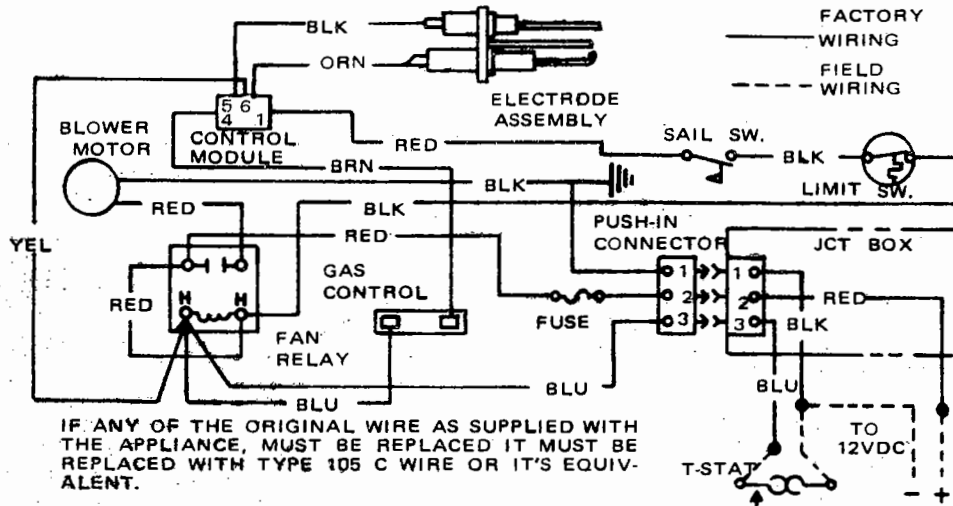

SCHEMATIC DIRECT SPARK IGNITION MODELS

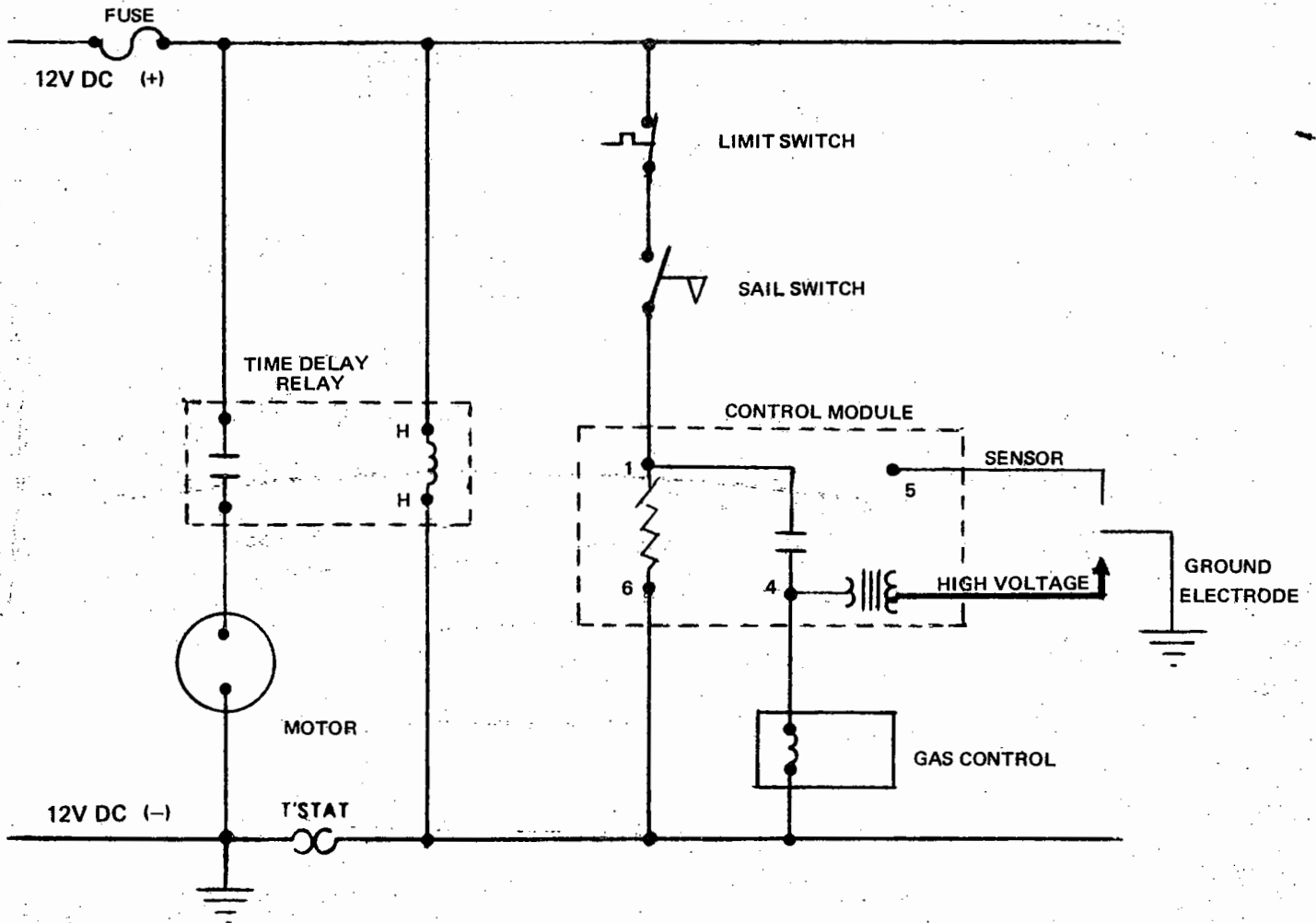

DUO-THERM

Heater and Furnace

LIMITED ONE YEAR WARRANTY

Duo-Therm warrants all new Duo-Therm Heaters and Furnaces to be free from defects in material and workmanship for one (1) year from date of delivery to the original consumer purchaser. This warranty is made for the benefit of the original consumer purchaser only and is void if the heater or furnace is not properly installed, operated and maintained; nor shall it cover damage caused by shipment, mishandling, electrical supply, improper fuel supply, adjustments, nozzle or orifice replacement, or air from an air conditioner circulating through the furnace, lightning and/or other acts of God.

For warranty service, contact the nearest authorized Duo-Therm Service Dealer. If you cannot locate one, contact nearest Duo-Therm Warehouse Service Office listed below describing the problem and the model and serial number of the heater or furnace. The date of purchase must be established with a receipt or cancelled check to obtain warranty service. This warranty is void if the model and serial number name plate is altered, defaced or removed.

Duo-Therm will replace or at it's option, repair any part or parts that prove to be defective within the applicable provision of this warranty. Replacement parts will be shipped within the continental United States and Canada only and via the most economical method of transportation. No payment will be made for parts purchased or repaired without authorization from Duo-Therm. The warranty on all replacement or repair parts shall be for the unexpired term of the original warranty. Duo-Therm will pay it's established warranty labor rates to authorized service dealers for warranty work. No payment will be made under warranty for travel time or mileage on units designed for recreational vehicle use. This warranty does not cover defects or damage resulting from work performed by unauthorized service dealers.

Duo-Therm warrants the heat chamber to be free from defects in material and workmanship for five (5) years from date of delivery to the original consumer purchaser. Duo-Therm will replace or, at it's option, repair a heat chamber that proves to be defective within the applicable provisions of this warranty. After five (5) years, should the heat chamber prove to be defective within the applicable provisions of this warranty, Duo-Therm will supply a replacement heat chamber at a pro-rated price as follows of the then current list price for such heat chambers.

Within the sixth year from date of delivery - 50%
Within the seventh year from date of delivery - 60%

Within the eighth year from date of delivery - 70%
Within the ninth year from date of delivery - 80%

Within the tenth year from date of delivery - 90%

This heat chamber warranty does not cover labor, freight or any other charges - except during the first year of warranty.

In the event a heat chamber is not available, a credit toward purchase of a new Duo-Therm furnace will be allowed in an amount equivalent to the published list price of the replacement heat chamber when last available at the percentage shown below for the applicable year as follows.

Within the second year from date of delivery - 90%
Within the third year from date of delivery - 80%
Within the fourth year from date of delivery - 70%
Within the fifth year from date of delivery - 60%

Within the sixth year from date of delivery - 50%
Within the seventh year from date of delivery - 40%
Within the eighth year from date of delivery - 30%
Within the ninth year from date of delivery - 20%

Within the tenth year from date of delivery - 10%

This heat chamber warranty does not cover labor, freight or any other charges. Under no circumstances will cash credits be issued.

THIS WARRANTY IS IN LIEU OF ALL OTHER WARRANTIES. ANY IMPLIED WARRANTY, INCLUDING WARRANTIES OF MERCHANTABILITY OR FITNESS FOR A PARTICULAR PURPOSE, IS LIMITED IN DURATION TO THE DURATION OF THIS WRITTEN WARRANTY AND OTHERWISE EXCLUDED. Some States do not allow limitations on how long an implied warranty lasts, so the above limitation may not apply to you. In no event shall Duo-Therm be liable for incidental or consequential damages. Some States do not allow the exclusion or limitation of incidental or consequential damages, so the above limitation or exclusion may not apply to you. This warranty gives you specific legal rights, and you may also have other rights which vary from State to State.

DUO-THERM

Telephone: 219-463-2191

KEEP THIS CERTIFICATE IN A SAFE PLACE. IT MUST BE AVAILABLE FOR INSPECTION WHEN REQUESTING WARRANTY SERVICE.