

# **Dometic®** **INSTALLATION AND OPERATING INSTRUCTIONS**

**REFRIGERATOR FOR LP-GAS AND ELECTRIC OPERATION.**

**RM 2620 RM 2820**

## CLASSIC

### **FOR YOUR SAFETY**

**If you smell gas:**

- 1. Open windows.**
- 2. Don't touch electrical switches.**
- 3. Extinguish any open flame.**
- 4. Immediately call your gas supplier.**

### **FOR YOUR SAFETY**

**Do not store or use gasoline or other flammable vapors and liquids in the vicinity of this or any other appliance.**

**WARNING: Improper installation, adjustment, alteration, service or maintenance can cause injury or property damage. Refer to this manual. For assistance or additional information consult a qualified installer, service agency or the gas supplier.**

### Contents:

	Page
Installation	4
Operating Instructions	7
Maintenance & Service	11



### **AVIS**

**Cet appareil doit être réparé seulement par un réparateur autorisé. Modification de l'appareil pourrait être extrêmement dangereuse, et pourrait causer mal ou mort.**

# **Dometic®**

*Our goal . . . your satisfaction.*

Corporate Office  
2320 Industrial Parkway Elkhart, IN 46515

**USA**  
Service Office  
The Dometic Corporation  
509 South Poplar Street  
LaGrange, IN 46761  
Phone: 219-463-4858

**For Service Center Assistance**  
Call: 800-544-4881

**CANADA**  
Dometic Distribution Inc.  
866 Langs Drive  
Cambridge, Ontario  
N3H 2N7 Canada  
Phone: 519-653-4390

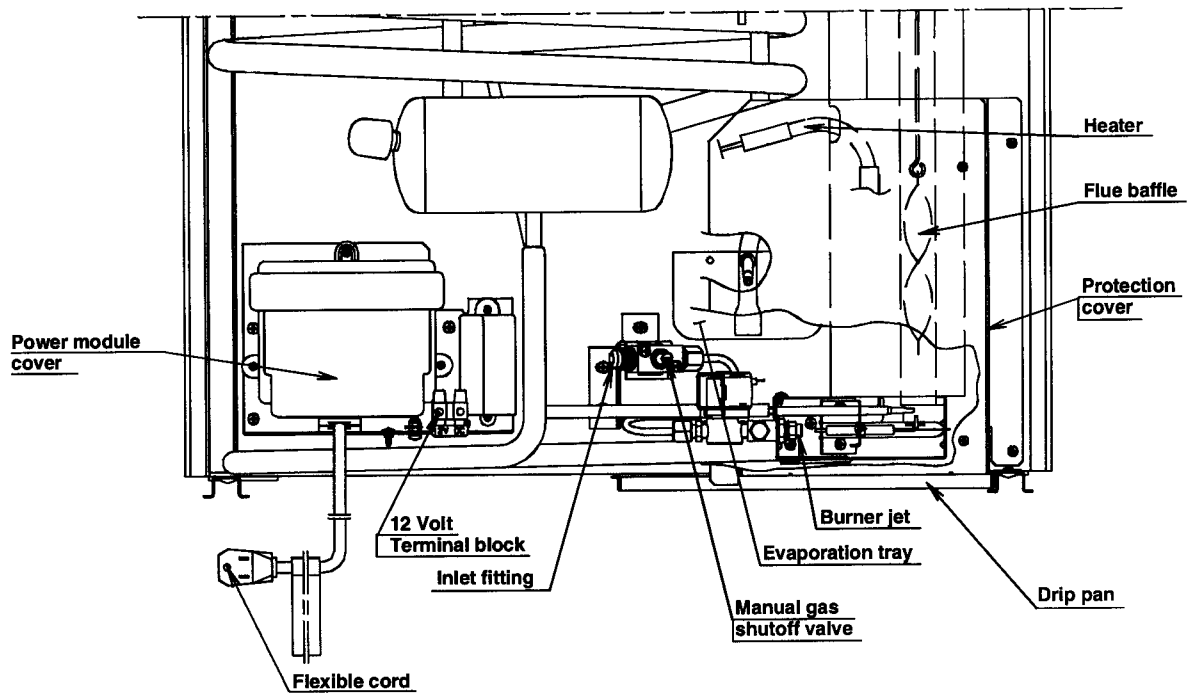

FIG. 1

Refrigerator control panel.

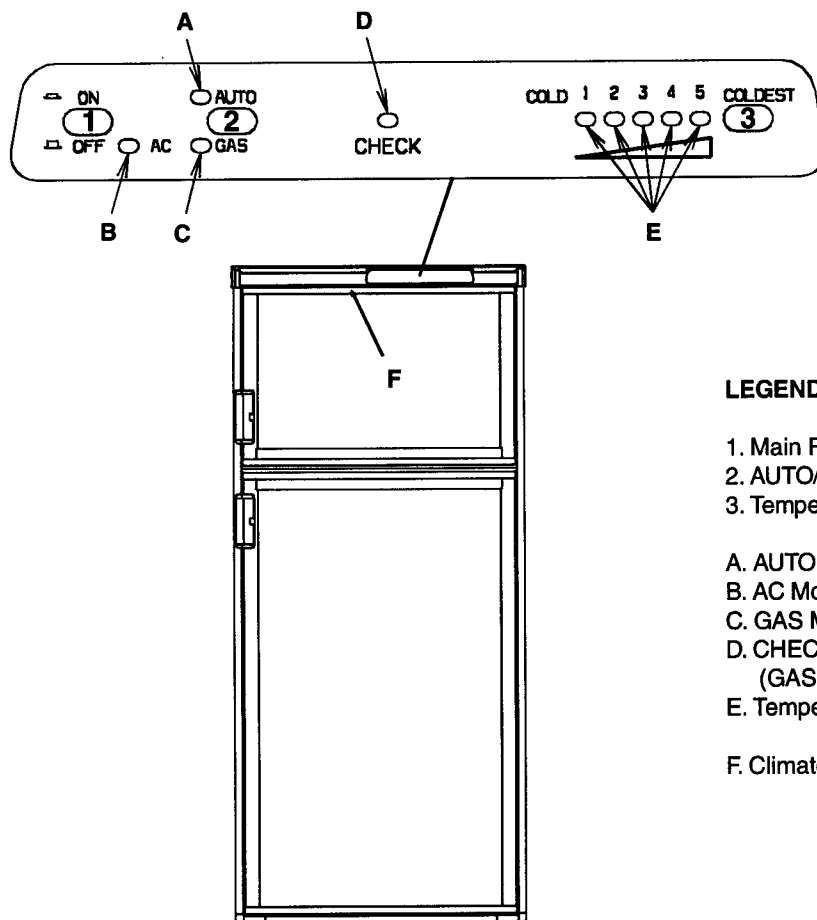

FIG. 2

LEGEND 2-WAY AMES Model

- 1. Main Power Button ON/OFF
- 2. AUTO/GAS Mode Selector Button
- 3. Temperature Selector Button

- A. AUTO Mode Indicator Lamp
- B. AC Mode Indicator Lamp
- C. GAS Mode Indicator Lamp
- D. CHECK Indicator Lamp  
(GAS Mode Only)
- E. Temperature Indicator Lamps

- F. Climate Control Switch

# INSTALLATION

## GENERAL INSTRUCTION

**This appliance is designed for storage of foods and storage of frozen foods and making ice.**

The refrigerators outlined herein have been design certified by A.G.A. under the ANSI Z21.19 Refrigerator Standard for installation in a mobile home or recreational vehicle and are approved by the Canadian Gas Association.

The certifications are, however contingent on the installation being made in accordance with the following instructions as applicable.

**In the U.S.A., the installation must conform with:**

1. National Fuel Gas Code ANSI Z223.1-(latest edition)
2. Manufactured Home Construction and Safety Standard, Title 24 CFR, Part 3280.
3. Recreational Vehicles ANSI A119.2-(latest edition).

The unit must be electrically grounded in accordance with the National Electric Code ANSI/NFPA 70-(latest edition) when installed, if an external alternating current electrical source is utilized.

4. Any applicable local code.

**In CANADA, the installation must conform with:**

1. Current CAN/CGA B 149 Gas Installation Codes
2. Current CSA Standard Z 240.4 GAS-EQUIPPED RECREATIONAL VEHICLES AND MOBILE HOUSING.
3. Where a flexible metal connector is used, it must comply with the provisions of the current Standard CAN1-6.10, METAL CONNECTORS FOR GAS APPLIANCES
4. Any applicable local code

The unit must be electrically grounded in accordance with the current CANADIAN ELECTRICAL CODE C 22 Parts 1 and 2.

## VENTILATION

The installation shall be made in such a manner as to separate the combustion system from the living space of the mobile home or recreational vehicle. Openings for air supply or for venting of combustion products shall have a minimum dimension of not less than 1/4 inch.

Proper installation requires one lower fresh air intake and one upper exhaust vent. The ventilation kits shown in this instruction manual have been certified for use with the refrigerator models listed in the table. For "Certified Vent System Kits" see page 15. The ventilation kits must be installed and used without modification. An opening toward the outside at floor level in the refrigerator compartment must be provided for ventilation of heavier-than-air fuel gases. The lower vent of the recommended kits is provided with proper size openings. The flow of combustion and ventilating air must not be obstructed.

The lower side vent is fitted with a panel that provides an adequate access opening for ready serviceability of the burner and control manifold of the refrigerator.

## GAS CONNECTION

Hook-up to the gas supply line is accomplished at the manual gas valve, which is furnished with a 3/8" SAE (UNF 5/8" -18) male flare connection. All completed connections should be checked for leaks with soapy water.



**DO NOT use a flame to check for gas leaks.**

The gas supply system must incorporate a pressure regulator to maintain a supply pressure of not more than 11 inches water column.

When testing the gas supply system at test pressures in excess of 1/2 psig, the refrigerator and its individual shutoff valve must be disconnected from the gas supply piping system.

When testing the gas supply system at pressures less than or equal to 1/2 psig, the appliance must be isolated from the gas supply piping system by closing its individual manual shutoff valve.

In case detailed instructions on the installation and connection to the gas supply are required, contact your dealer or distributor.

## ELECTRICAL CONNECTION

### 120 Volts AC Connection

The refrigerator is equipped with a three-prong (grounded) plug for protection against shock hazards and should be plugged directly into a properly grounded three-prong receptacle. DO NOT cut or remove the grounding prong from this plug. The free length of the cord is 2 feet and therefore recommended that the receptacle be located to the left side of the refrigerator (viewed from the rear) and approximately 6 inches from the floor (see FIG. 3). This allows easy access through the vent door. The cord should be routed to avoid direct contact with the burner cover, flue cover or any other components that could damage the cord insulation.

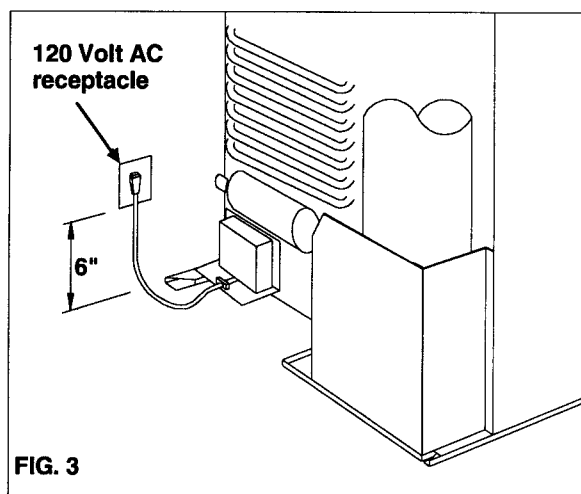

FIG. 3

## 12 Volts DC Connection

This refrigerator model is not designed for 12 volt DC operation of the cooling system; however, a continuous 12 volt DC must be supplied to the refrigerator to operate the controls. Use a **minimum of a 14 gauge wire** between the battery and refrigerator to supply the control voltage. The connection is made to the positive (+) and negative (-) terminals of the terminal block on the back of the refrigerator. (See FIG. 1).

Correct polarity must be observed when connecting to the DC supply.

**DO NOT** use the chassis or vehicle frame as one of the conductors. Connect two wires at the refrigerator and route to the DC supply.

## INSTALLING REFRIGERATOR IN ENCLOSURE

**NOTE: DO NOT** install the appliance directly on carpeting. Carpeting must be removed or protected by a metal or wood panel beneath the appliance which extends at least full width and depth of the appliance.

The refrigerator must be installed in a substantial enclosure and must be level. When installing the refrigerator in the enclosure, all areas within the recess in which the refrigerator is installed must be sealed.

Make sure that there is a complete seal between the front frame of the refrigerator and the top, sides and bottom of the enclosure. A length of sealing strip is applied to the rear surface of the front frame for this purpose. Also apply a sealing strip to the foremost floor of the enclosure and apply a second sealing strip to the bottom of the trim strip on the front base as shown in FIG. 4. The sealing should provide a complete isolation of the appliance's combustion system from the vehicle interior.

**NOTE:** Be careful not to damage the sealing strip applied to the floor of the enclosure when the refrigerator is put in place.

### Securing the refrigerator

After the refrigerator is put in place, (ensuring a combustion seal at the front frame), the refrigerator is to be secured in the enclosure with six screws. The screws have to be installed in the following order:

**STEP 1:** Two Screws installed on front base.

**STEP 2:** Two Screws installed in the top frame.

**STEP 3:** Two Screws installed in the rear base.

**STEP 4:** The refrigerator is provided with a lower front strip (shipped as a loose part). The front strip is to be attached after the refrigerator is set into the cutout opening, and secured with 3 screws. (See FIG. 5).

Failure to follow the sequence in securing refrigerator in enclosure can cause leakage between the frame and cabinet. Plastic caps are provided to cover the screw holes in the decoration strip, at the top frame. Any space between the counter, storage area or ceiling and top of

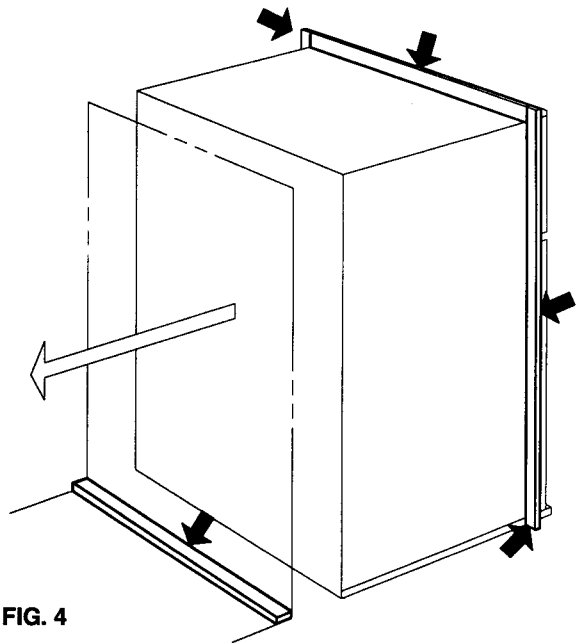

FIG. 4

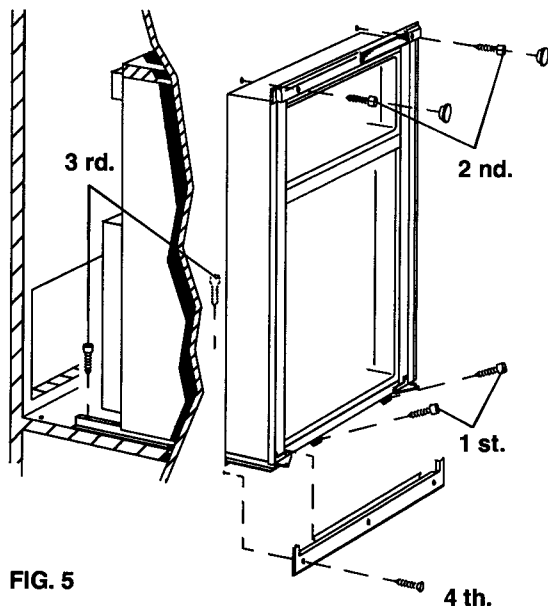

FIG. 5

the refrigerator greater than 1-1/2 inches should be blocked.

The heat produced at the rear of the refrigerator will become trapped in this space, making the top of the refrigerator hot and reduce the efficiency of the refrigerator.

## TESTING LP GAS SAFETY SHUTOFF

The gas safety shutoff must be tested after the refrigerator is connected to LP gas supply.

To test the gas safety shutoff, proceed as follows:

1. Start the refrigerator and switch to GAS mode. (see start up instructions).
2. Check that the gas flame is lit and the GAS mode indicator lamp (C) is on.
3. Close the manual gas shutoff valve at the back of the refrigerator. (See FIG. 1).
4. Wait for one minute. The CHECK indicator lamp (D) should be on and the GAS mode indicator lamp (C) should be off.
5. Remove protection cover (see FIG. 1) and open the manual gas shutoff valve. Do not change any button positions on the control panel. Apply a non-corrosive commercial bubble solution to the burner jet orifice.
6. No bubbles should appear at the opening of the burner jet orifice. The presence of bubbles indicates a defective gas safety shutoff, and service is required.
7. If no bubbles were present at the burner jet orifice, it should be rinsed with fresh water. Be careful not to damage the burner jet orifice. Replace cover and press the main power ON/OFF button (1) OFF and back ON. Normal operation of the burner should return. Allow the burner to operate for a minimum of five minutes.

## CERTIFIED INSTALLATION

Certified installations require one roof vent and one lower side vent.

For "Certified Vent System Kits" see page 15.

For further information contact your dealer or distributor.

## METHODS OF INSTALLATION

The method of installation is shown in FIG. 6. It is essential that all maximum or minimum dimensions are strictly maintained, as the performance of the refrigerator is dependent on adequate flow of air over the rear of the refrigerator.

## VENTILATION HEIGHTS

Installation with roof vent and lower side vent	Minimum ventilation heights in	
	Inches	mm
Refrigerator		
RM 2620	54	1372
RM 2820	60	1524

## CLEARANCES

Minimum clearances in inches to combustible materials are:

G: Top 0

K: Side 0

L: Bottom 0

M: Rear 0

N: See NOTE: Clearance "N" below.

NOTE: Clearance "M" is between the rearmost part of the refrigerator and the wall behind the refrigerator.

NOTE: The upper vent should be centered over the condenser coil at the back of the refrigerator.

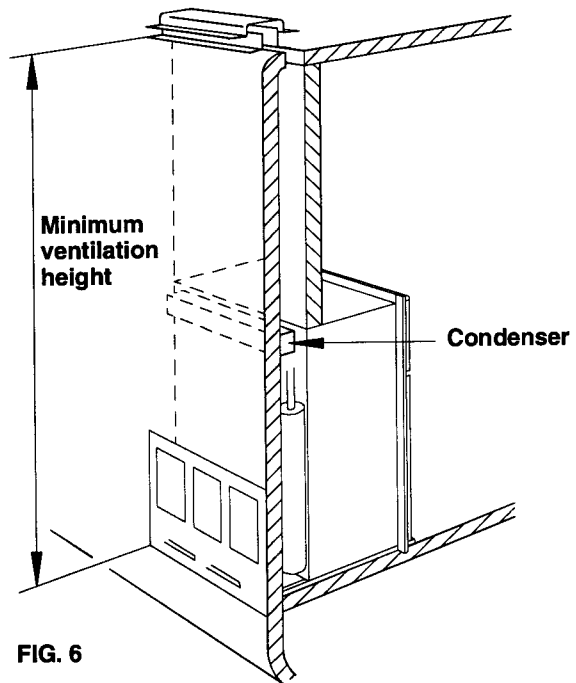

FIG. 6

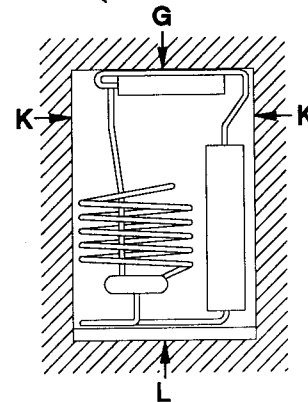
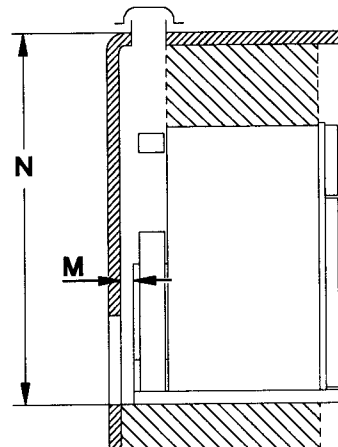

FIG. 7



NOTE: Clearance "N" is the distance between the bottom of the lower vent to the roof material. For ventilation height, see table VENTILATION HEIGHTS See Figures 6, and 7.

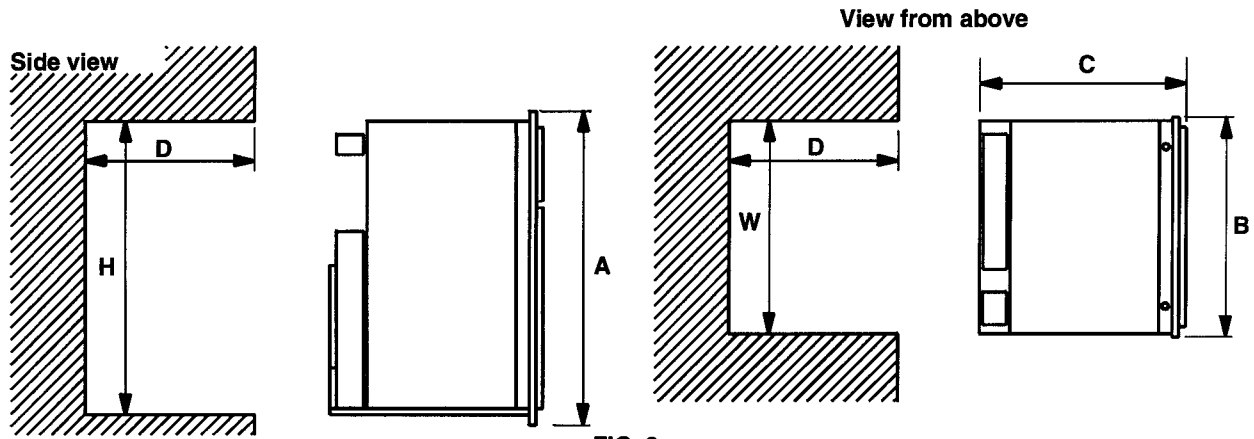

FIG. 8

Refrigerator Model	Overall Dimensions			Recess Dimensions			
	Height A	Width B	Depth C	Height H	Width W	Depth D	
RM 2620	inch	51-31/32	22-23/32	24-9/16	49-17/32	21-13/16	24-3/32
	mm	1320	577	624	1258	554	612
RM 2820	inch	57-7/8	24-39/64	24-9/16	55-7/16	23-11/16	24-3/32
	mm	1470	625	624	1408	601	612

This method of installation and these clearances will give you adequate space for service and proper installation.

## OPERATING INSTRUCTIONS

### IMPORTANCE OF LEVELING A REFRIGERATOR

In an absorption refrigerator system, ammonia is liquefied in the finned condenser coil at the top rear of the refrigerator. The liquid ammonia then flows into the evaporator (inside the freezer section) and is exposed to a circulating flow of hydrogen gas, which causes the ammonia to evaporate, creating a cold condition in the freezer.

The tubing in the evaporator section is specifically sloped to provide a continuous movement of liquid ammonia, flowing downward by gravity through this section. If the refrigerator is operated when it is not level and the vehicle is not moving, liquid ammonia will accumulate in sections of the evaporator tubing. This will slow the circulation of hydrogen and ammonia gas, or in severe cases, completely block it, resulting in a loss of cooling.

Any time the vehicle is parked for several hours with the refrigerator operating, the vehicle should be leveled to prevent this loss of cooling. The vehicle needs to be leveled only so it is comfortable to live in (no noticeable sloping of floor or walls).

When the vehicle is moving, the leveling is not critical, as the rolling and pitching motion of the vehicle will pass to either side of level - keeping the liquid ammonia from accumulating in the evaporator tubing.

## OPERATION

Before starting the refrigerator, check that all the manual gas valves are in the ON position. DO NOT forget the manual shutoff valve on the rear of the refrigerator see FIG. 1.

This refrigerator is equipped with a semi Automatic Energy Selector (AMES) control system, which can automatically select the most suitable energy source which is available, either AC or LP gas operation, or if desired, LP gas only.

The refrigerator controls will work down to 9.6 volt DC.

**Most LP gas appliances used in recreational vehicles are vented to the outside of the vehicle. When parked close to a gasoline pump, it is possible that the gasoline fumes could enter this type of appliance and ignite from the burner flame, CAUSING A FIRE OR AN EXPLOSION.**

**FOR YOUR SAFETY, when refueling, shut off all LP gas appliances which are vented to the outside.**

## Refrigerator control panel.

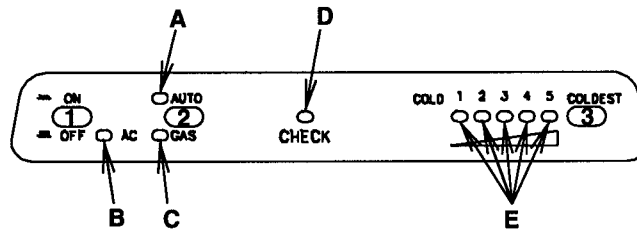

## START UP INSTRUCTIONS

- A. A continuous 12 volt DC supply must be available for the electronic control to function.
- B. Press the main power ON/OFF button (1) to the DOWN position.
- C. Press the TEMPERATURE SELECTOR button (3) until the lamp at the desired setting is illuminated.

### AUTO MODE

1. Press the AUTO/GAS mode selector button (2) to turn ON the Auto lamp (A). If 120 volts AC is available, the AC mode indicator lamp (B) will illuminate indicating AC operation. If 120 volts AC is not available, the GAS mode indicator lamp (C) will illuminate and the control system will automatically switch to GAS operation.
2. If the CHECK indicator lamp (D) illuminates and the GAS mode indicator lamp (C) is off, the controls have failed to ignite the burner in the GAS mode. GAS operation may be reset by pressing the main power ON/OFF button (1) to the OFF then ON position. (See step 2 under GAS MODE).
3. Press the TEMPERATURE SELECTOR button (3) until the lamp at the desired position is illuminated.

### GAS MODE

1. Press the AUTO/GAS mode selector button (2) to turn OFF the Auto lamp (A). The GAS mode indicator lamp (C) will illuminate. Within 45 seconds the burner should be ignited and operating normally.
2. On the initial refrigerator start-up, it may take longer than 45 seconds to allow air to be purged from the gas line. If the gas does not ignite within 45 seconds the CHECK indicator lamp (D) will illuminate and the GAS mode indicator lamp (C) will go off. To reset when the CHECK indicator lamp (D) is illuminated, press the main power ON/OFF button (1) to the OFF and then ON position.  
**NOTE:** Do not continue to reset GAS operation if the CHECK indicator lamp continues to be illuminated after several tries.
3. Press the TEMPERATURE SELECTOR button (3) until the lamp at the desired position is illuminated.

## THERMOSTAT

The thermostat on the refrigerator controls both the gas and electric operation, thereby eliminating the necessity of resetting each time a different energy source is employed.

After the initial start-up, the thermostat should be moved from "COLDEST" to the desired temperature setting, usually about mid setting.

## TO SHUT OFF THE REFRIGERATOR

The refrigerator may be shut off while in any mode of operation by pressing the main power ON/OFF button to the UP (OFF) position. This shuts off all DC power to the refrigerator, including the interior light.

## Refrigerator control panel.

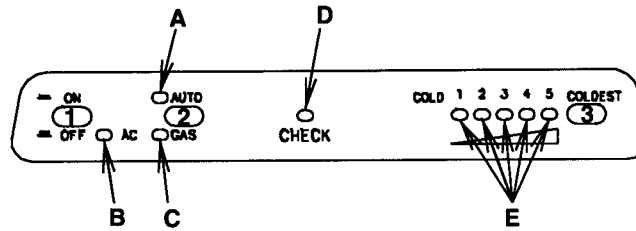

## DESCRIPTION OF OPERATING MODES

### AUTO MODE

When operating in the AUTO mode, the AUTO mode indicator lamp (A) will illuminate. The control system will automatically select between AC and GAS operation with AC having priority over GAS. Either the AC indicator lamp (B) or the GAS indicator lamp (C) will illuminate depending on the energy source selected by the control system. If the control system is operating with AC energy and it then becomes unavailable, the system will automatically switch to GAS. As soon as AC becomes available again the control will switch back to AC regardless of the status of GAS operation.

### GAS MODE

When operating in the GAS mode, the AUTO mode indicator lamp (A) will be off and the GAS mode indicator lamp (C) will be illuminated. This mode provides LP gas operation only. The control system will activate the ignition system and will attempt to light the burner for a period of approximately 45 seconds. If unsuccessful, the CHECK indicator lamp (D) will illuminate and the GAS mode indicator lamp (C) will turn off.

To restart GAS operation, press the main power ON/OFF button (1) to the OFF and then ON position. The control system will attempt a new 45 second ignition sequence.

If the refrigerator has not been used for a long time or the LP tanks have just been refilled, air may be trapped in the supply lines. To purge the air from the lines may require resetting the main power ON/OFF button (1) three or four times. If repeated attempts fail to start the LP gas operation, check to make sure that the LP gas supply tanks are not empty and all manual shutoff valves *in the lines are open. If the problem is still not corrected,* contact a service center for assistance.

If the control is switched to AC operation while the CHECK indicator lamp is on, it will function properly, but the CHECK indicator lamp will not go off until the main power ON/OFF button is pressed to the OFF then ON position.

## LIMP MODE OF OPERATION

This control system contains a feature where it will continue to operate the cooling system in the event of a failure of a major operating component. Two different modes of operation can occur in this category.

If for some reason the display module becomes non functional, the control system will revert to full automatic operation selecting the best energy source available with AC, GAS priority. The temperature of the refrigerator will be maintained at the MID position within normal temperature tolerances. The power module will continually attempt to re-establish operation of the display module.

The second limp mode of operation will execute when a failure of the temperature sensing device or associated electronic circuitry occurs. If this should occur, the control system will operate on the energy source selected via the control panel. The cooling unit will run continuously on the selected energy source. The refrigerator will continue to operate in this mode indefinitely or until a new sensor is installed and the system is reset.



# HOW TO USE THE REFRIGERATOR

## FOOD STORAGE COMPARTMENT

The food storage compartment is completely closed and unventilated, which is necessary to maintain the required low temperature for food storage. Consequently, foods having a strong odor or those that absorb odors easily should be covered. Vegetables, salads etc. should be covered to retain their crispness. The coldest positions in the refrigerator are under the cooling fins and at the bottom of the refrigerator. The warmer areas are on the upper door shelves. This should be considered when placing different types of food in the refrigerator.

## FROZEN FOOD STORAGE COMPARTMENT

Quick frozen soft fruits and ice cream should be placed in the coldest part of the compartment, which is on or just below the freezer shelf. Frozen vegetables, may be stored in any part of the compartment.

This compartment is not designed for deep or quick freezing of food. Meat or fish, whether raw or prepared, can be stored in the frozen food storage compartment provided they are pre-cooled first in the refrigerator. They can be stored about three times longer in the frozen food compartment as compared to the fresh food compartment. To prevent food from drying out, keep it in covered dishes, containers, plastic bags or wrapped in aluminum foil.

*Ice cubes can be made in the freezer compartment.*

For faster ice making, the trays should be placed in direct contact with the freezer shelf.

Ice will be made more rapidly if the thermostat is set at its highest position.

It is a good idea to do this a few hours before the anticipated need for ice, but be sure to move back to normal setting, usually about mid setting when the ice is formed. Food in the lower compartment may be frozen if the setting is left on "COLDEST" position.

Total Refrigerated Volume RM 2620 is 6.0 cu.ft.

Total Refrigerated Volume RM 2820 is 7.7 cu.ft.

## DEFROSTING

Shut off the refrigerator by pressing the main power ON/OFF button to the UP (OFF) position. Empty the refrigerator, leaving the drip tray under the finned evaporator, and the cabinet and freezer doors open. Filling the ice trays with hot water and placing them in the freezer compartment can reduce defrosting time.

**DO NOT use a hot air blower. Permanent damage could result from warping the metal or plastic parts. DO NOT use a knife or an ice pick, or other sharp tools to remove frost from the freezer shelf. They can create a leak in the ammonia system.**

When all frost is melted, dry the interior of the refrigerator with a clean cloth. Replace all food and set the thermostat to the COLDEST temperature setting for a few hours. Then reset the thermostat to the desired setting, usually at mid setting.

**NOTE:** On these models the drip tray/cup is on the rear side of the refrigerator. (See FIG. 1)

Move the plastic drain tube in to a watertight bucket or container. (Access through louvered service panel on the outside of the vehicle.) As the frost melts, the water will flow into the container. When all the frost has melted wipe up the excess moisture and empty the accumulated water from the bucket. Replace the drain tube to its original position.

## CLEANING

Cleaning the refrigerator is usually done after it is defrosted or put into storage. To clean the interior liner of the refrigerator, use lukewarm weak soda solution. Use only warm water to clean the finned evaporator and shelves. **NEVER** use strong chemicals or abrasives to clean these parts, as the protective surfaces will be damaged. It is important to always keep the refrigerator clean.

## SHUT OFF - STORAGE PROCEDURE

Shut off the refrigerator by pressing the main power ON/OFF button to the UP (OFF) position.

If the refrigerator will not be in operation for a period of weeks, it should be emptied, defrosted, cleaned and the doors left ajar. The ice trays should also be dried and kept outside the cabinet.

**DO NOT store explosive substances in the refrigerator, such as cigarette lighter gas, petrol, ether or the like.**

## CLIMATE CONTROL HEATER

During the summer months of high temperatures and humidity, the metal frame between the freezer and fresh food compartments may have water droplets forming. The number of water droplets will increase if the vehicle isn't air conditioned during these months.

This refrigerator comes standard with a 12 volt (DC) climate control that will evaporate the water droplets when they form.

To have the climate control on, you position the switch ("F" see figure 2) located beneath the top decoration panel that houses the control panel to ON. The climate control can be left on continuously or only used when temperatures require it.

**NOTE:** The climate control will draw 12 volts DC power continuously when in the ON position. It should be turned OFF when a charging source is not available.

## GAS EQUIPMENT ASSEMBLY

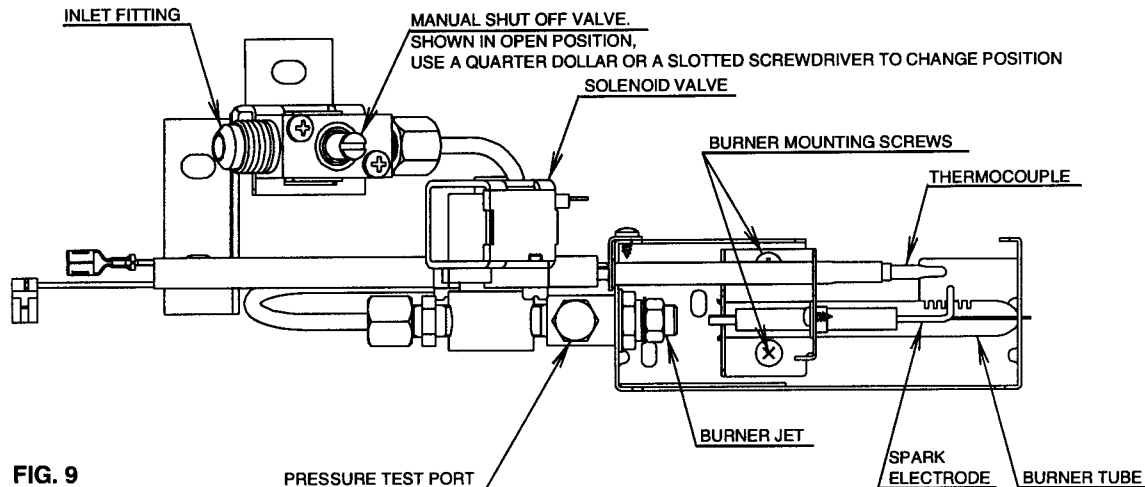

FIG. 9

### ELECTRIC EQUIPMENT CARTRIDGE HEATER

The heat necessary for the operation of an absorption cooling unit is supplied by an electric heater mounted in a pocket of the boiler system. These models are equipped with one electrical heater for 120 volt AC.

To replace the heater proceed as follows:

1. Disconnect the wall plug, and the 12 volt wires.
2. Remove the protection cover see FIG. 1
3. Remove the power module cover see FIG. 1
4. Disconnect the heater leads.
5. With a pair of pliers unfold the lug holding the lid of the boiler casing and open the lid.
6. Remove some insulation wool so that the heater is accessible.
7. Turn and lift the heater out of its pocket.
8. Fit the new heater into the pocket.
9. Connect the leads and put on the power module cover.
10. Reset the insulation and close the lid of the boiler.
11. Replace the protection cover.

### FUSES

These models are equipped with 2 fuses, one for the refrigerator control system and one for AC cartridge heater. (See table below).

To replace fuse(s) proceed as follows.

1. Disconnect the wall plug, and the 12 volt wires.
2. Remove the power module cover. See FIG. 1.
3. Snap the fuse out of the fuse holder.
4. Fit a new fuse in to the fuse holder.
5. Replace the power module cover.

Control system	3 Amp
AC heater	5 Amp

## MAINTENANCE & SERVICE

The user should be aware of service that must be done on a regular schedule to keep the refrigerator operating properly. The service should only be performed by a qualified technician who is familiar with LP gas systems and refrigerators.

### 1. REFRIGERATOR REMOVAL

Before working on the refrigerator, make sure the AC voltage and DC voltage leads are disconnected. Shut off the gas supply. Disconnect the gas supply line at the rear of the refrigerator; (see FIG. 1.). Always use a back up wrench when loosening and tightening this connection. Cap the gas supply line, loosen the screws anchoring the refrigerator to the enclosure and slide the refrigerator out of the compartment. When replacing the refrigerator make sure that the sealing strips are properly positioned. Replacement is the reverse of removal. Check all gas connections for leaks. Refer to section **INSTALLATION**, page 4 to 7.

### 2. PERIODIC MAINTENANCE

To keep your Dometic refrigerator operating efficiently and safely, periodic inspection and cleaning of several components once or twice a year is recommended.

- A. It is important to keep the area at the back of the refrigerator clean. Check the lower vent, upper vent and area between these openings for any obstructions such as bird/insect nests, spider webs, etc. Clean the coils on the back of the refrigerator. Use a soft bristled brush to dust off the coils. It is important to keep the refrigerator area free from combustible material, gasoline and other flammable vapors or liquids.

**NOTE:** The following maintenance is required once or twice a year, but should only be done by a qualified serviceman who is familiar with LP gas systems and refrigerators.

- B. Check all connections in the LP gas system (at the back of the refrigerator) for gas leaks. The LP gas supply must be turned on. Apply a non-corrosive bubble solution to all LP gas connections. The appearance of bubbles indicates a leak and should be repaired **immediately** by a QUALIFIED SERVICE-MAN WHO IS FAMILIAR WITH GAS SYSTEM AND REFRIGERATORS.

**DO NOT** use a flame to check for gas leaks.

- C. Check the AMES control system by connecting/disconnecting 120 volt AC power, start/stop the engine, etc. Compare the operation with the operation described in description of operating modes. Page 9.
- D. The LP gas pressure should be checked and the main regulator re-adjusted if pressure is incorrect. The correct operating pressure is 11 inches of water column. The correct place to take the LP gas pressure is at the test port just ahead of the burner jet. (See FIG. 9).
- E. Inspect the flue baffle. It should be reasonably clean and free of soot. Heavy soot formation indicates improper functioning of the burner. The flue and burner both require cleaning in the following manner:
1. Unplug the refrigerator power cord from the 120 volt AC outlet. (See FIG. 3).
  2. Disconnect or shut off the 12 volt power to the refrigerator.
  3. Turn manual shutoff valve to OFF. (See FIG. 1).
  4. Remove cover from the burner housing. (See FIG. 1).
  5. Disconnect the wire from the high voltage electrode.
  6. Remove the burner mounting screws and remove the burner assembly. (See FIG. 9).
  7. Remove the flue cap from top of flue tube and lift out the wire and spiral baffle. Clean the flue from the top using a flue brush. Blowing compressed air into the flue **will not** properly clean soot and scale out of the flue tube. Replace spiral baffle and flue cap.
  8. Clean burner tube with a brush. Blow out burner with compressed air.
  9. Before removing burner jet, clean burner area of soot and scale that fell out of flue tube. Remove the burner jet. Soak the jet in wood alcohol and blow it out with compressed air. Re-install and tighten burner jet.  
**NOTE:** The color of the flame shall be clear blue over the slots of the burner. (See FIG. 10).

Clear blue color of flame

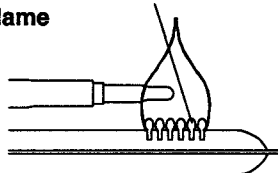
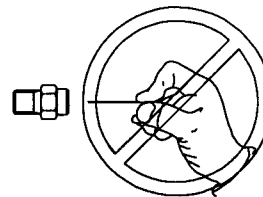

FIG. 10

**DO NOT** use a wire or pin when cleaning the burner jet as damage can occur to the precision opening. This can cause damage to the refrigerator or create a fire hazard.



10. Reinstall burner, being careful that the end of the burner fits into the slot on the burner bracket. Check to make sure slots are centered under the flue tube and the thermocouple is positioned properly (tip of thermocouple extends over two slots of burner).
11. Be sure to reconnect the wire to high voltage electrode. Check the electrode for proper location and gap. (See FIG. 11).

FIG. 11

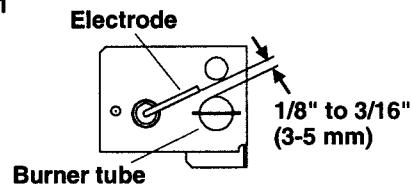

12. Turn on manual gas shutoff valve and check all fittings for leaks.
13. Connect 120 volt power cord to the outlet and reconnect or turn on the 12 volt DC power.
14. Check LP gas safety shutoff. See page 6.

## TROUBLESHOOTING

### The Refrigerator Does Not Cool Properly

- A. Burner jet clogged.  
Clean. (See section Maintenance & Service, Item 2. Periodic Maintenance, Paragraph E. Item 1-14).
- B. Check level of refrigerator.
- C. Venting problem.  
Restriction in air flow across cooling unit.
- D. Heavy frost buildup on evaporator fins.  
Defrost.
- E. Flue baffle not inserted properly in flue tube.
- F. Improperly set thermostat.  
See section Operating Instructions, part Start Up Instructions.
- G. Burner dirty.  
Clean. See section Maintenance & Service, Item 2. Periodic Maintenance, Paragraph E. Item 1-14.

- H. LP gas pressure low at burner.  
Set main regulator so pressure does not drop below 11 inches water column at pressure tap.
- I. Burner not located properly under flue tube.  
Relocate.
- J. Burner damaged.  
Replace.
- K. Odors from fumes.
  1. Dislocated burner.
  2. Damaged burner.
  3. Dirty flue tube.
- L. FUSES
  1. Refrigerator AC Supply.
  2. Control system. See page 11, part Fuses.

**NOTE: AVOID SPRAYING WATER THROUGH THE REFRIGERATOR VENTS WHILE WASHING YOUR RV.**

All the above instructions are to be followed closely. The refrigerator is quality-guaranteed. However, we are not responsible for any failures caused by improper adjustments and unfavorable installation conditions. Contact service point or distributor service dept. for assistance.

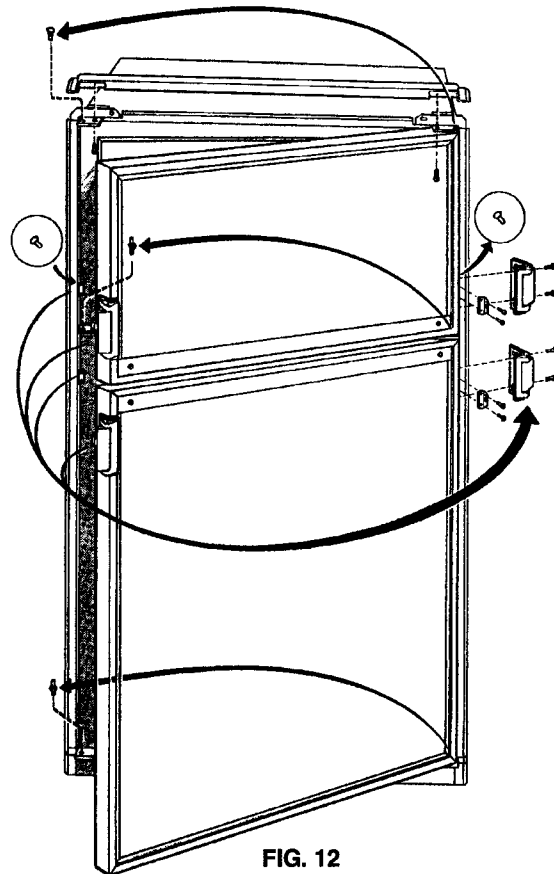

FIG. 12

## CHANGING DOOR HINGES FROM ONE SIDE TO THE OTHER

Open the top door and remove the two screws holding the top decoration. The screws are accessible from beneath. (See FIG. 12)

Remove the top hinge pin and lift out the top door. Remove center hinge pin and lift out the lower door. Unscrew the bottom hinge pin. Remove the plastic cap from the opposite lower hinge and place it in the hole just "left empty" by the lower hinge pin. Screw the lower hinge pin in the hole from which the plastic cap was removed.

Before replacing the doors on the refrigerator, remove the catches and move them to the opposite side of the cabinet. The screw holes are covered with plastic caps that must be removed and inserted in the screw holes that previously held the catches. NOTE: The plastic caps are not installed on new refrigerators and are in the parts bag.

Remount the doors and hinge pins in the reverse order of their removal. Unscrew the handles and re-fasten them on the opposite side of the door. Insert the plastic caps (from the parts bag) into the holes left open on the doors. Check the door gaskets. If they are correct, then replace the top decoration.

## INSTRUCTIONS FOR MOUNTING THE DOOR PANEL

The refrigerator is normally delivered without door panels. Before starting the mounting work, check that the panel dimensions are in compliance with those given in the table and the instructions are read thoroughly.

When mounting the panel, proceed as follows):

- A. On new refrigerators, the decoration strips are taped inside the door; if installed on the door, remove the door decoration strip (2) by removing its two screw (1).
- B. Insert one vertical edge into the groove of the door frame (3).
- C. Bend the panel gently so that the free side of the panel can be slipped into the corresponding groove of the door frame (4). Slide the panel down into the groove of the bottom frame (5).
- D. Between the upper edge of the panel and the door frame there is a gap which should be covered by the decoration strip.
- E. Put the decoration strip across the door so that the gap is covered and push it upward (6). The tabs on the inside of the strip should fit behind the flange of the door frame. Secure the decoration strip with the two screws removed in Step A (1).

PANEL DIMENSIONS MAX. THICKNESS 5/32" (4 mm)						
REFR. MODELS TYPE		HEIGHT		WIDTH		
		MAX.	MIN.	MAX.	MIN.	
RM 2620	upper	mm	306	304	515	513
		inch	12-3/64	11-31/32	20-9/32	20-13/64
	lower	mm	819	817	515	513
		inch	32-1/4	32-5/32	20-9/32	20-13/64
RM 2820	upper	mm	378	376	563	561
		inch	14-7/8	14-51/64	22-11/64	22-3/32
	lower	mm	897	895	563	561
		inch	35-5/16	35-15/64	22-11/64	22-3/32

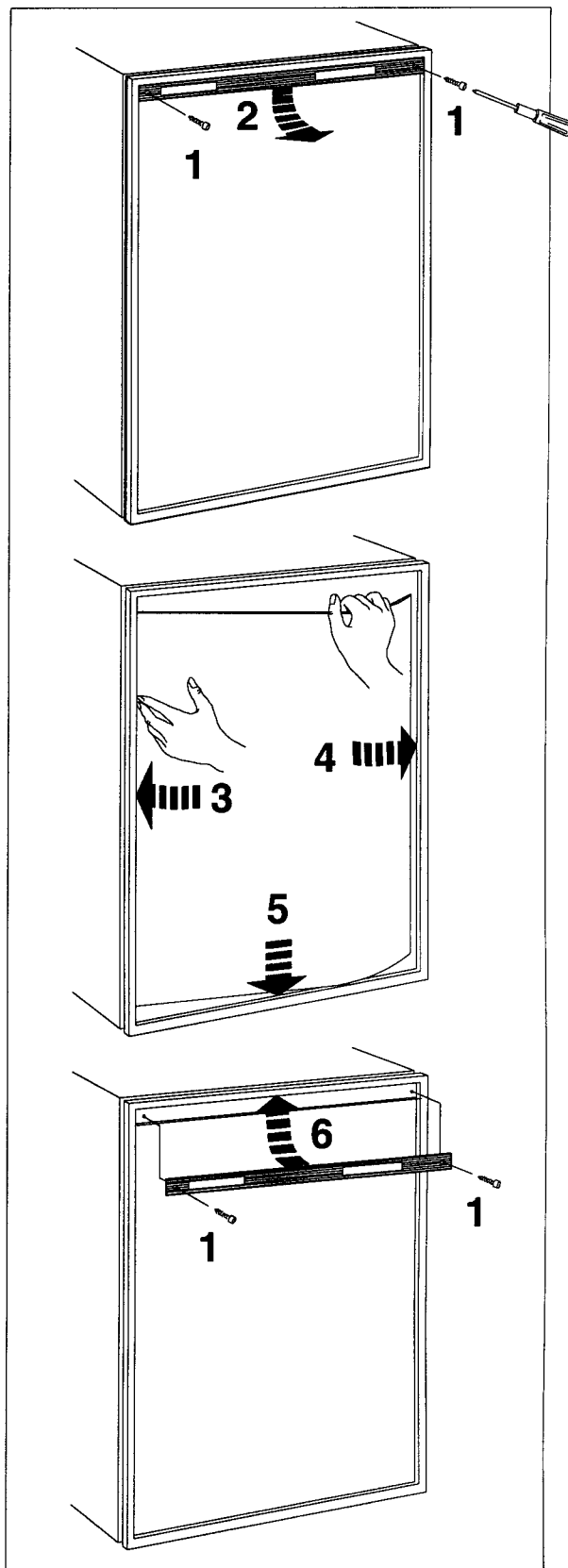

## CERTIFIED VENT SYSTEM KITS

Refr. Model	Kit No.	Components	Drawing
RM 2620 RM 2820	4A	Roof Vent	3103633.xxx* Base 3103634.xxx* Cap (Both Required)
		Lower Side Vent	3102277.xxx*

\* Fill in "xxx" with color code numbers. For color codes, contact your supplier

For further information, contact your dealer or distributor.

### SPARE PARTS

The following list is a list of commonly used parts which should be available, if required, from your Dometic Service Center.

**A = RM 2620**

**B = RM 2820**

Part No.	Description
200 74 19-19/1	A - Jet, No. 53
200 74 19-21/7	- B Jet, No. 58
293 06 97-02/0	A B Burner
293 03 79-00/9	A B Electrode
200 75 90-05/8	A - Baffle
200 75 90-06/6	- B Baffle
293 11 32-01/9	A B Spark ignition device
17 37 54-19/3	A - Heater, 295W, 120V
17 37 42-18/0	- B Heater, 325W, 120V
293 18 26-01/6	A B Thermocouple
293 14 18-03/8	A B Door shelf, (freezer)
200 05 71-25/3	A - Door shelf, 4 pieces
200 17 32-18/5	- B Door shelf, 4 pieces
200 27 26-06/1	A - Box vegetable-, 2 pieces
200 27 26-16/0	- B Box vegetable-, 2 pieces
293 21 06-01/2	A B Lamp cover
293 16 00-02/3	A B Handle, cpl.

**Contact an authorized service center for parts and repairs as needed.**

